

CUSTOMER DRAWING

REV.	DESCRIPTION	APPROVED BY	DATE	ECN NO.
△B	CHANGE CLAMP RING MATERIAL	Ku Chou	31/10/18'	
△C	ADD P/N	Ku Chou	24/04/19'	
△D	ADD P/N	Ku Chou	26/08/20'	

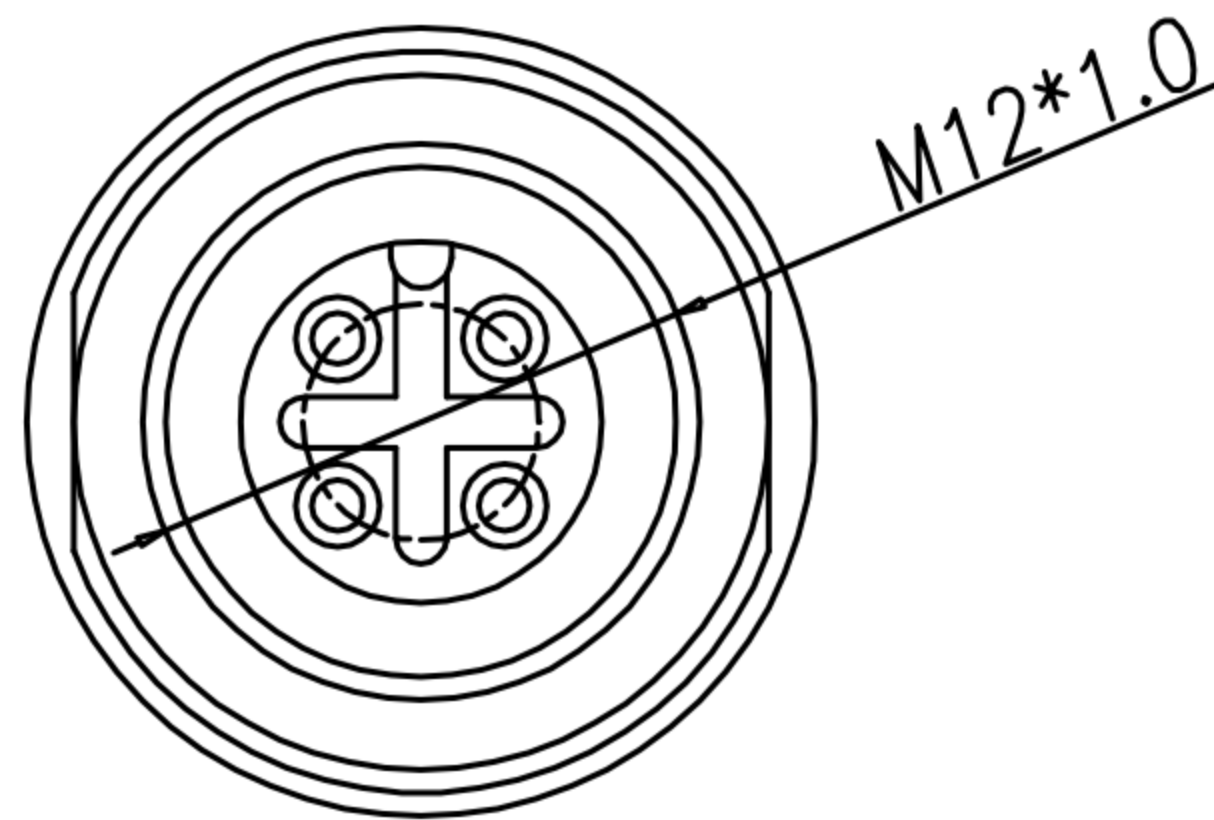
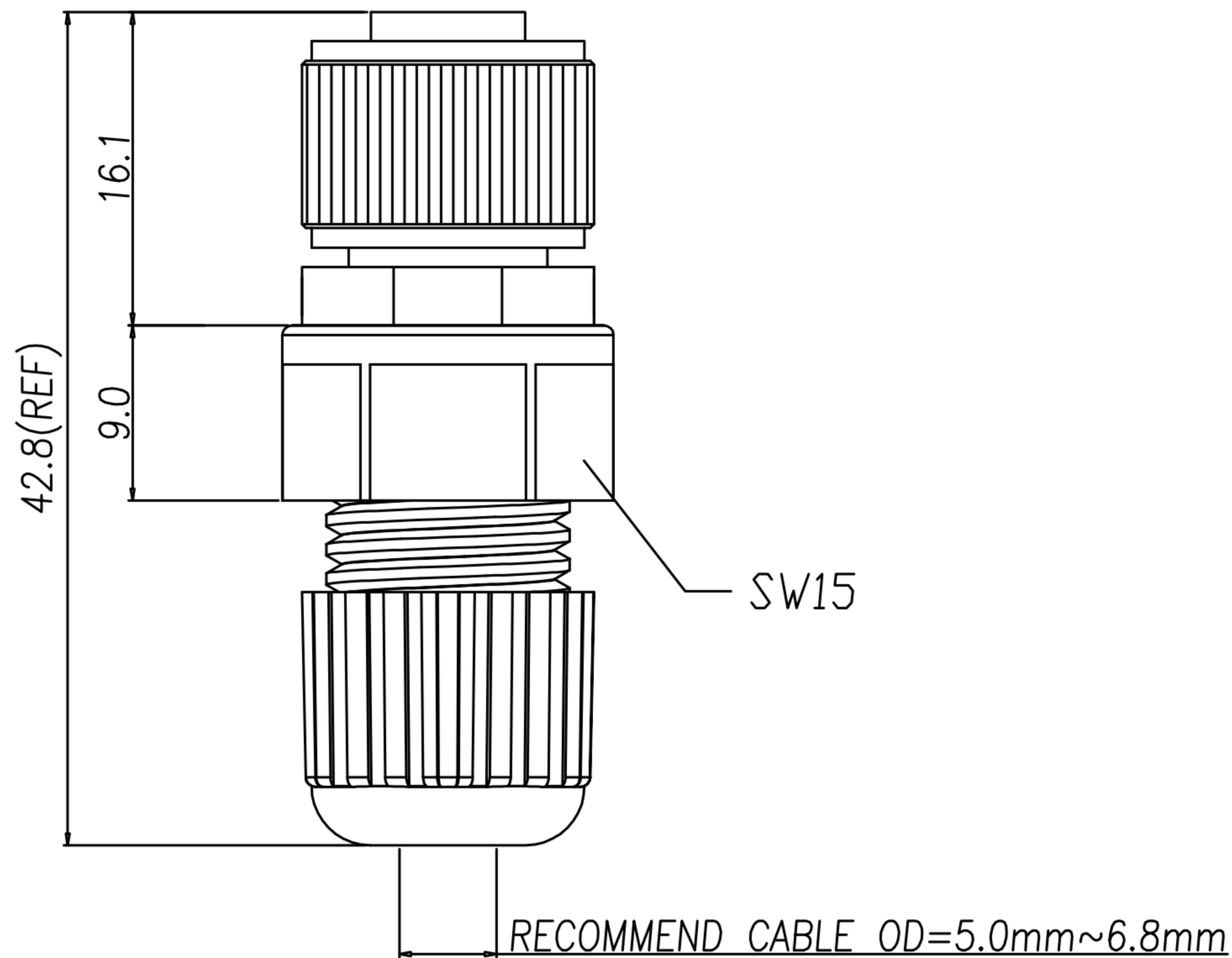

TABLE A

WP-05F2-156-11	WP-04F2-199-11	WP-03F2-148-11	WP-03F2-118-11	WP-02F2-90-11	WP-02F2-89-11



1. MATERIAL :

- 1-1. HOUSING : PBT UL94V-0 ; COLOR : BLACK.
- 1-2. CONTACT : BRASS
- 1-3. SHELL : BRASS
- 1-4. O-RING : EPDM
- 1-5. NUT : ALUMINUM ALLOY
- 1-6. GASKET : SILICONE
- 1-7. CLAMP RING : PA66 △B
- 1-8. SEAL : SILICONE
- 1-9. SEALING NUT : PA66

2. FINISH :

- 2-1. CONTACT : GOLD FLASH PLATED.
- 2-2. NUT : NICKEL PLATED.
- 2-3. SHELL : NICKEL PLATED.

3. ELECTRICAL SPECIFICATION :

- 3-1. Rated current : 4A
- 3-2. Rated voltage : 2~4PIN 250V ; 5PIN 60V
- 3-3. Water proof : IP67

4. Environmental :

- 4-1. Operation Temperature : -40℃~105℃

DRAWN	Emily Suen	APP'D	Ku Chou	UNIT	mm	TOLERANCE		广东科斯达电子科技有限公司 GUANG DONG KE SI DA ELECTRONIC TECHNOLOGY CO., LTD.	TITLE	M12 (F) A-coded Assembly type(塑膠本體)			SHEET	1 VERSION D
CHK'D	Ku Chou			SCALE	1:1	.x ±0.20 .xx ±0.10 .xxx ±0.05 .xxxx ±0.03 ANGULA ±1°			PART NO.	SEE TABLE A	DWG NO.	QC8676		