

CUSTOMER DRAWING

REV.	DESCRIPTION	APPVL. BY	DATE	ECN NO.
△C	RELEASE	Fido Weng	11/04/13'	
△D	ADD P/N	Ku Chou	04/06/19'	
△E				

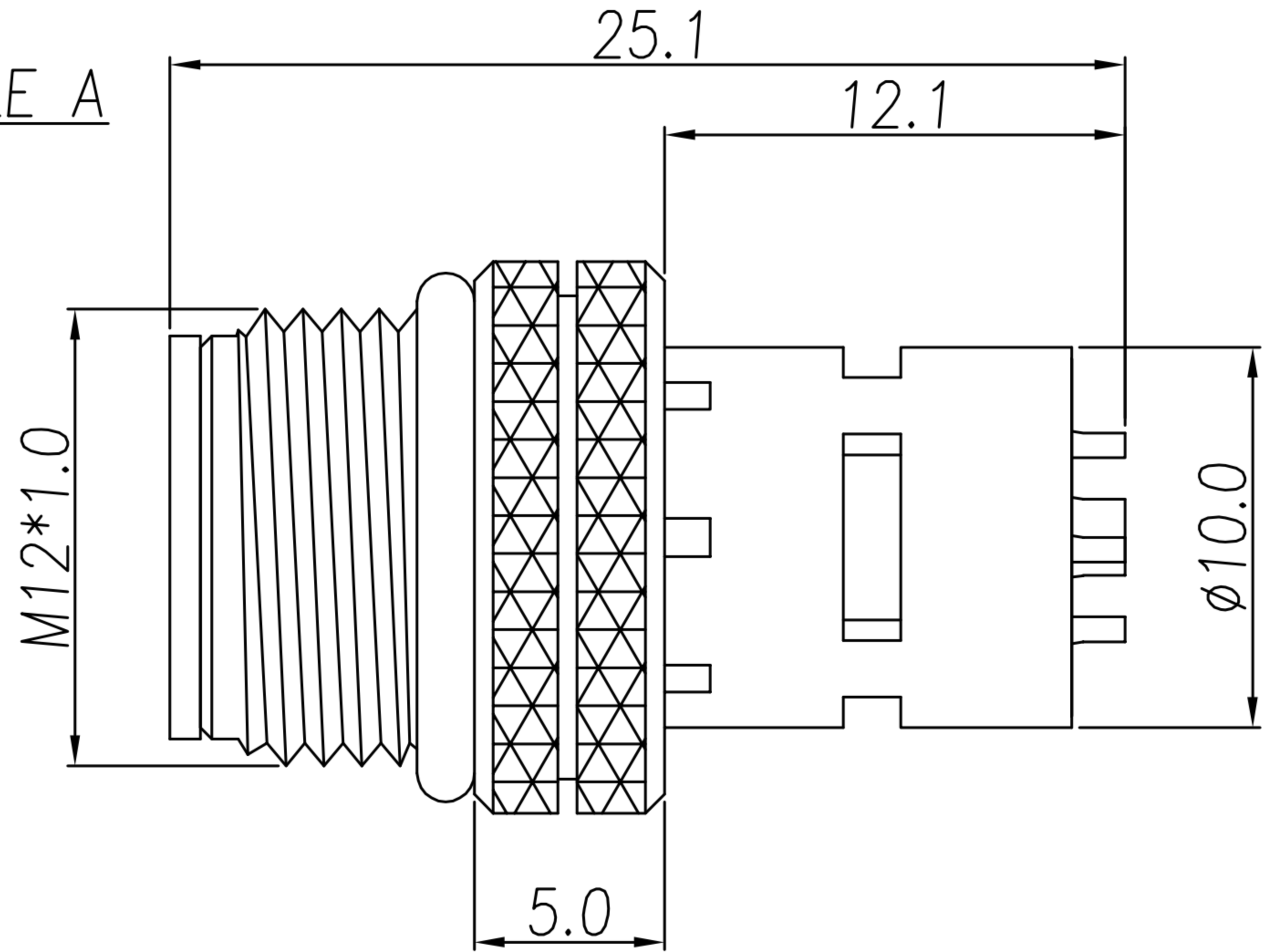
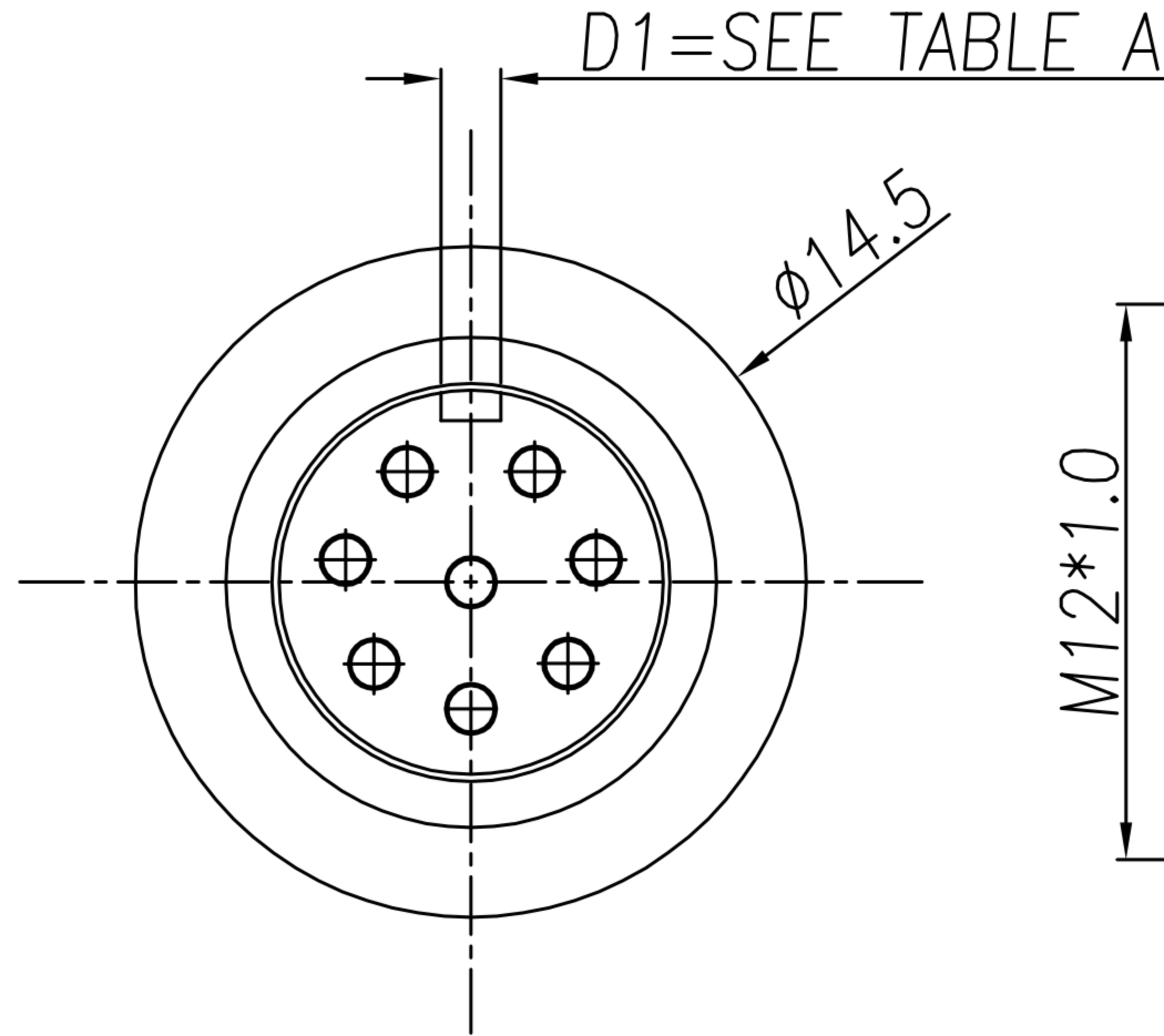
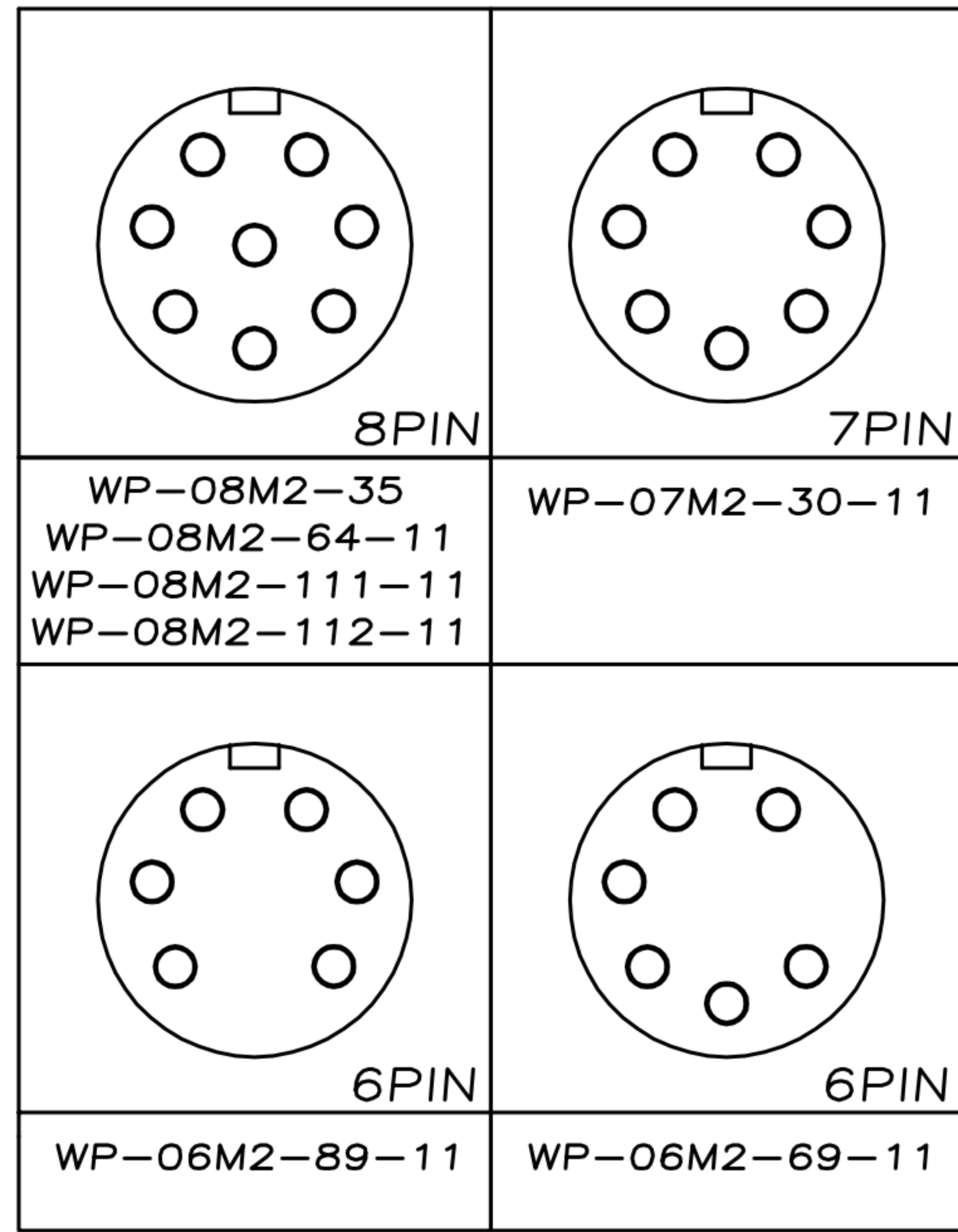

- MATERIAL :
 - HOUSING : PBT UL94V-0 ; COLOR : BLACK
 - CONTACT : BRASS
 - NUT : SEE TABLE A
 - O-RING : EPDM ; COLOR : BLACK
 - SHELL : SEE TABLE A

- FINISH :
 - CONTACT : SEE TABLE A
UNDER PLATE : NICKEL
 - NUT : SEE TABLE A
 - SHELL : SEE TABLE A

- ELECTRICAL SPECIFICATION :
 - Rated current : 2A
 - Rated Voltage : 30V
 - Water proof : IP67

- Environmental :
 - Operation Temperature : -40℃~85℃

TABLE A

WP-08M2-111-11	STAINLESS STEEL 316	PASSIVATION	STAINLESS STEEL 316	PASSIVATION	GOLD 10u"	1.1
WP-08M2-112-11	BRASS	BRIGHT TIN PLATED	STAINLESS STEEL 316	PASSIVATION	GOLD 10u"	1.1
WP-08M2-64-11	BRASS	BRIGHT TIN PLATED	BRASS	NICKEL PLATED	GOLD 10u"	1.1
WP-08M2-35	BRASS	BRIGHT TIN PLATED	BRASS	NICKEL PLATED	GOLD FLASH	1.1
WP-07M2-30-11	BRASS	BRIGHT TIN PLATED	BRASS	NICKEL PLATED	GOLD FLASH	1.1
WP-06M2-89-11	BRASS	BRIGHT TIN PLATED	BRASS	NICKEL PLATED	GOLD FLASH	1.1
WP-06M2-69-11	BRASS	BRIGHT TIN PLATED	BRASS	NICKEL PLATED	GOLD 10u"	1.3
PART NO	MATERIAL(SHELL)	FINISH(SHELL)	MATERIAL(NUT)	FINISH(NUT)	FINISH	D1

DRAWN	Emily Suen	APP'D	Ku Chou	UNIT	mm	TOLERANCE			广东科斯达电子科技有限公司 GUANG DONG KE SI DA ELECTRONIC TECHNOLOGY CO., LTD.	TITLE	防水頭 M12 (M) A-CODE 線端焊線式+接地			SHEET	1
CHK'D	Ku Chou	PART NO.	SEE TABLE A	DWG NO.	QC6163	VERSION				D					