

CUSTOMER DRAWING

REV.	DESCRIPTION	APPROVED BY	DATE	ECN NO.
A	RELEASE	Ku Chou	20/07/18'	
B	CHANGE CLAMP RING MATERIAL	Ku Chou	31/10/18'	
C				

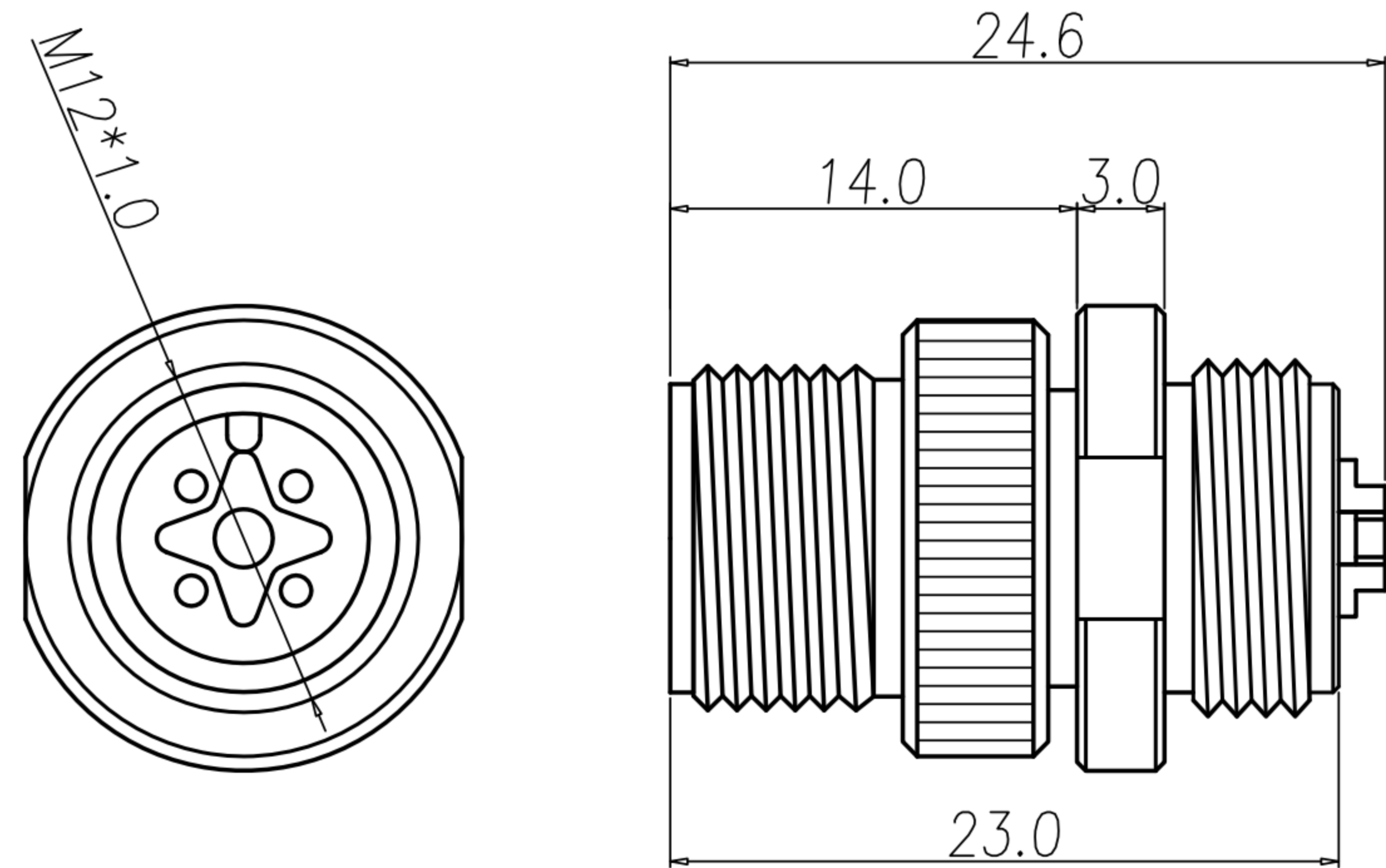

HOUSING & CONTACT & SHELL & NUT

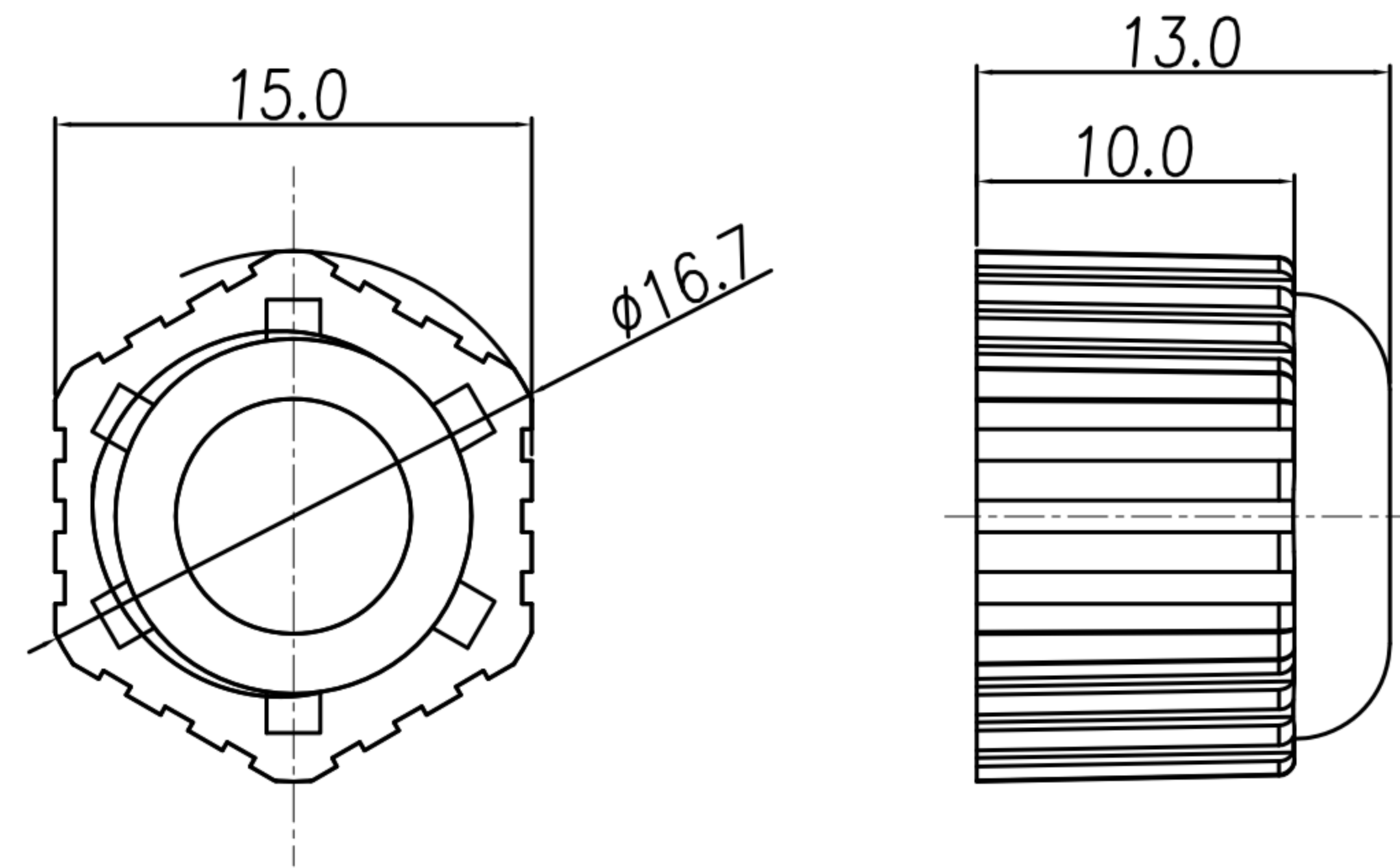

SEALING NUT

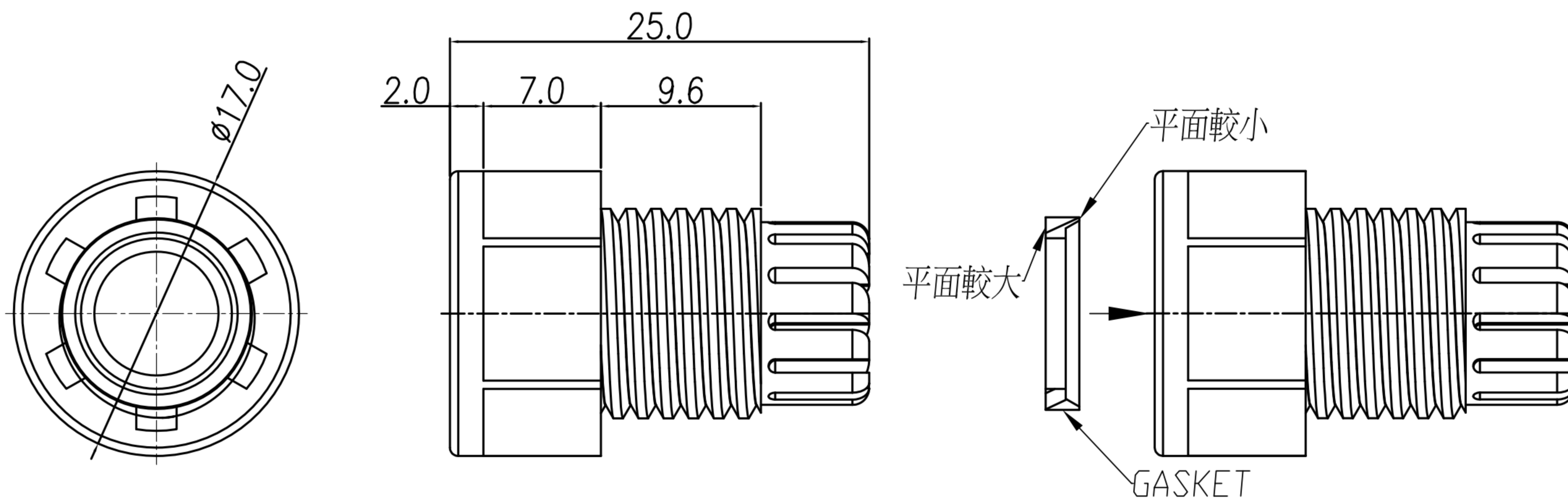

GASKET & CLAMP RING & SEAL

- MATERIAL :
 - 1-1. HOUSING : PBT UL94V-0 ; COLOR : BLACK.
 - 1-2. CONTACT : BRASS
 - 1-3. SHELL : BRASS
 - 1-4. NUT : ALUMINUM ALLOY
 - 1-5. GASKET : SILICONE
 - 1-6. CLAMP RING : PA66 Δ
 - 1-7. SEAL : SILICONE
 - 1-8. SEALING NUT : PA66
- FINISH :
 - 2-1. CONTACT : GOLD FLASH PLATED.
 - 2-2. NUT : NICKEL PLATED.
 - 2-3. SHELL : NICKEL PLATED.
- ELECTRICAL SPECIFICATION :
 - 3-1. Rated current : 4A
 - 3-2. Rated voltage : 2~4PIN 250V ; 5PIN 60V
 - 3-3. Water proof : IP67
- Environmental :
 - 4-1. Operation Temperature : -40℃~105℃

DRAWN	Emily Suen	APP'D	Ku Chou	UNIT	mm	TOLERANCE		广东科斯达电子科技有限公司 GUANG DONG KE SI DA ELECTRONIC TECHNOLOGY CO., LTD.	TITLE	M12 (M) A-coded Assembly type(塑膠本體)			SHEET	2/2 VERSION B
CHK'D	Ku Chou			SCALE	1:1	.x ±0.20 .xx ±0.10 .xxx ±0.05 .xxxx ±0.03 ANGULA ±1°			PART NO.	SEE TABLE A	DWG NO.	QC8673		

CUSTOMER DRAWING

REV.	DESCRIPTION	APPROVED BY	DATE	ECN NO.
△A	RELEASE	Ku Chou	20/07/18*	
△B	CHANGE CLAMP RING MATERIAL	Ku Chou	31/10/18*	
△C				

TABLE A

WP-05M2-130-11	WP-04M2-162-11	WP-03M2-112-11	WP-02M2-78-11
PIN ASSIGNMENTS FRONT VIEW			
		WP-03M2-144-11	WP-02M2-91-11

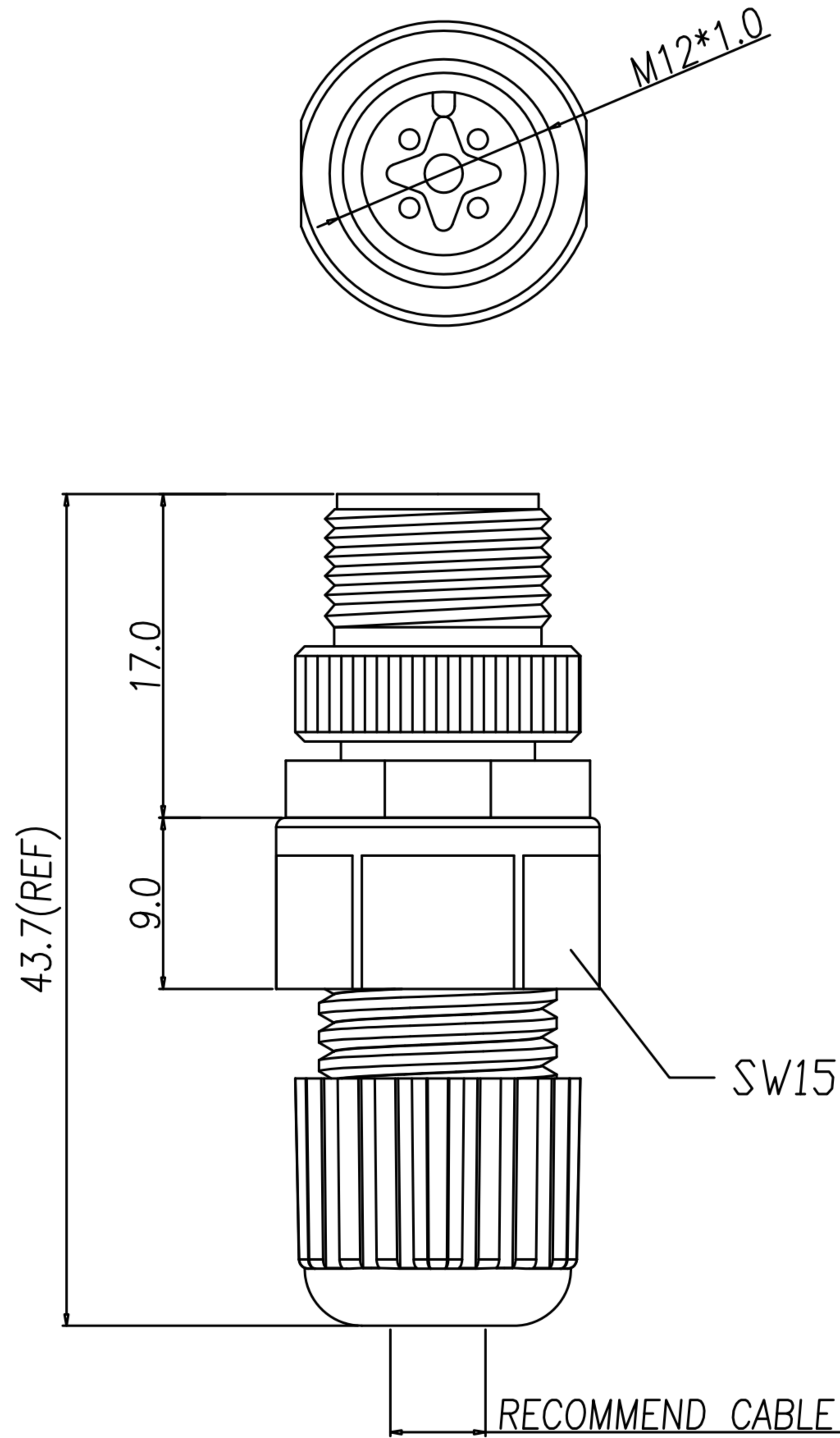

- MATERIAL :
 - 1-1. HOUSING : PBT UL94V-0 ; COLOR : BLACK.
 - 1-2. CONTACT : BRASS
 - 1-3. SHELL : BRASS
 - 1-4. NUT : ALUMINUM ALLOY
 - 1-5. GASKET : SILICONE
 - 1-6. CLAMP RING : PA66 △B
 - 1-7. SEAL : SILICONE
 - 1-8. SEALING NUT : PA66
- FINISH :
 - 2-1. CONTACT : GOLD FLASH PLATED.
 - 2-2. NUT : NICKEL PLATED.
 - 2-3. SHELL : NICKEL PLATED.
- ELECTRICAL SPECIFICATION :
 - 3-1. Rated current : 4A
 - 3-2. Rated voltage : 2~4PIN 250V ; 5PIN 60V
 - 3-3. Water proof : IP67
- Environmental :
 - 4-1. Operation Temperature : -40℃~105℃

DRAWN	Emily Suen	APP'D	Ku Chou	UNIT	mm	TOLERANCE		广东科斯达电子科技有限公司 GUANG DONG KE SI DA ELECTRONIC TECHNOLOGY CO., LTD.	TITLE	M12 (M) A-coded Assembly type(塑膠本體)			SHEET	1/2
CHK'D	Ku Chou			SCALE	1:1	.x ±0.20 .xx ±0.10 .xxx ±0.05 .xxxx ±0.03 ANGULA ±1°			PART NO.	SEE TABLE A	DWG NO.	QC8673	VERSION	B