

CUSTOMER DRAWING

REV.	DESCRIPTION	APPVL. BY	DATE	ECN NO.
A	RELEASE	Fido Weng	22/11/10'	
B	ADD TABLE A	Fido Weng	29/03/18'	

SEE TABLE A

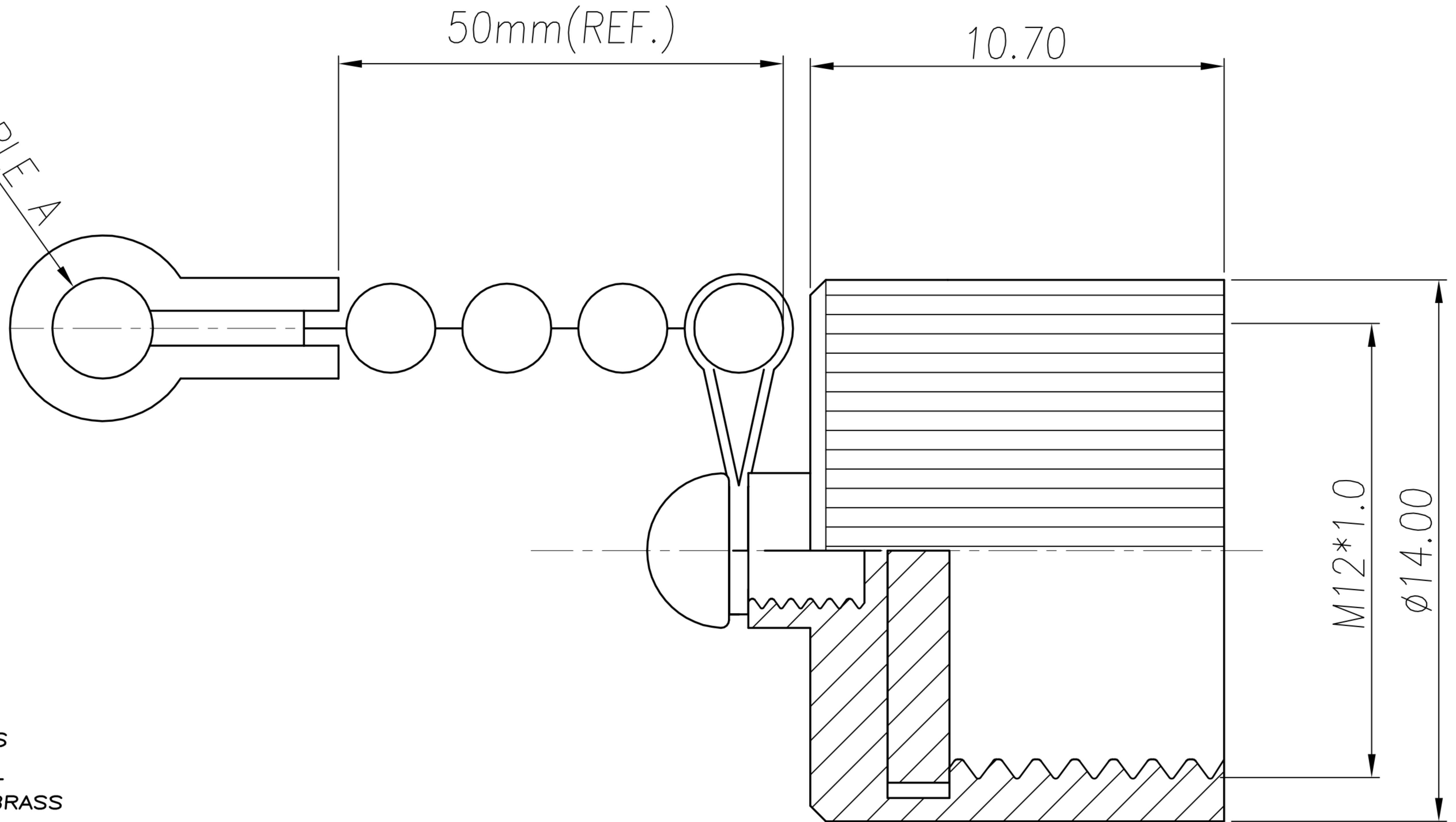

NOTE:

1. MATERIAL :
  - 1-1. COVER : BRASS
  - 1-2. SCREW : STEEL
  - 1-3. SNAP RING : BRASS
  - 1-4. BEAD CHAIN : STEEL
  - 1-5. O-RING : SILICONE ; COLOR : BLACK
2. FINISH :
  - 2-1. COVER : NICKEL PLATED.
  - 2-2. SCREW : NICKEL PLATED.
  - 2-3. SNAP RING : NICKEL PLATED.

TABLE A

NY-WP317	OD=2.4
NY-WP1105-10	OD=3.2

DRAW	Ku Chou	APPVL	Emily Suen	UNIT	mm	TOLERANCE		广东科斯达电子科技有限公司 GUANG DONG KE SI DA ELECTRONIC TECHNOLOGY CO., LTD.	TITLE	M12防塵蓋+鏈條(φ2.4*50mm)			SHEET	1
CHECK	Emily Suen			SCALE	1:1	.x ±0.30 .xx ±0.20 .xxx ±0.100 ANGULA ±2°			PART NO.	SEE TABLE A	DWG NO.	QC5104	VERSION	