

REV.	DESCRIPTION	APPROVED BY	DATE	ECN NO.
A	RELEASE	Ku Chou	17/03/20*	
B				
C				

Table A

WP-04M2-206-11	WP-03M2-119-11	WP-02M2-69-11

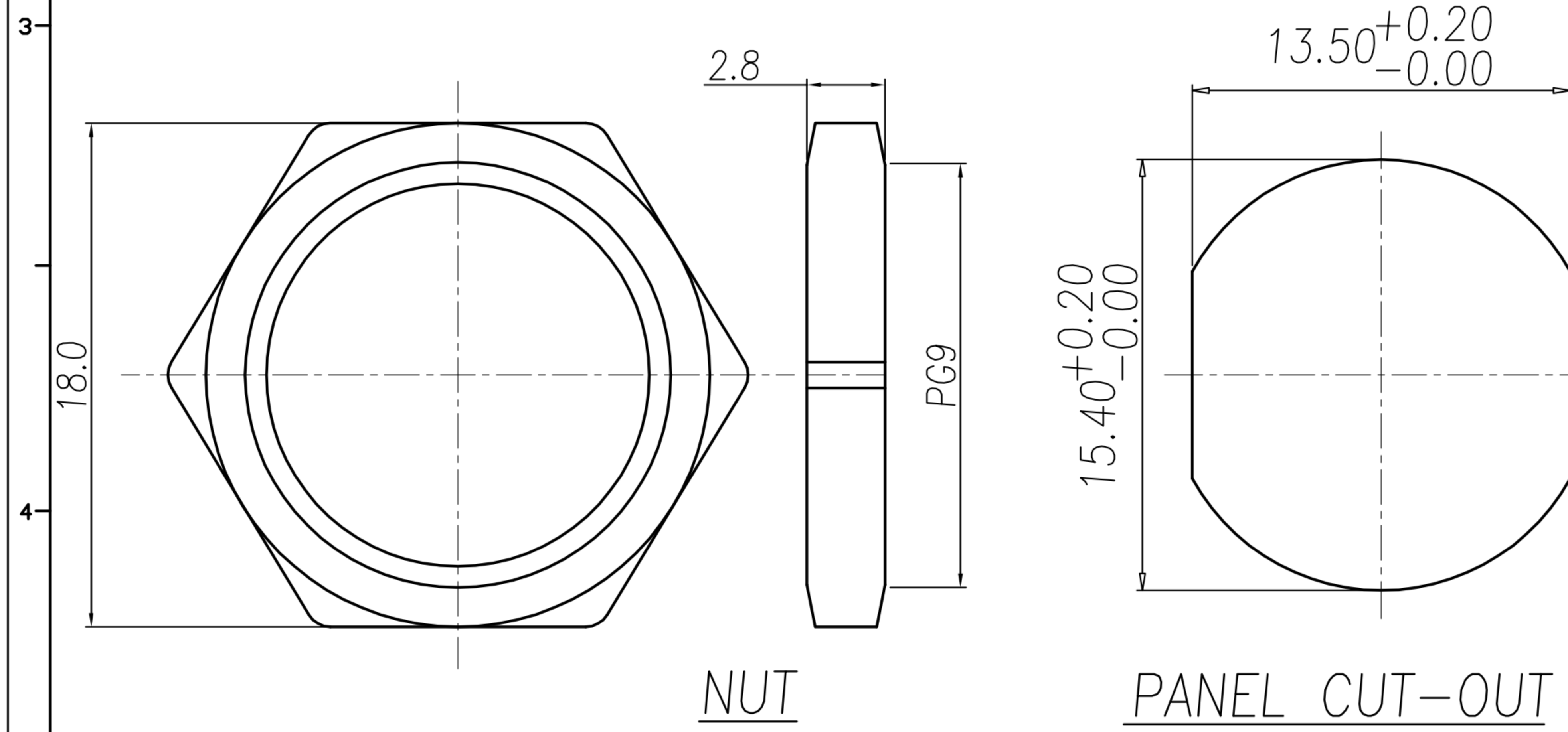

- MATERIAL :
  - 1-1. HOUSING : PA66 UL94V-0 ; COLOR : BLACK
  - 1-2. CONTACT : BRASS
  - 1-3. SHELL : BRASS
  - 1-4. O-RING : EPDM
  - 1-5. NUT : BRASS
- FINISH :
  - 2-1. CONTACT : 10u" MIN. GOLD PLATED  
UNDER PLATE : NICKEL
  - 2-2. SHELL : NICKEL PLATED
  - 2-3. NUT : NICKEL PLATED
- ELECTRICAL SPECIFICATION :
  - 3-1. Rated current : 12A
  - 3-2. Rated Voltage : 63V
  - 3-3. Water proof: IP67/68
- Environmental :
  - 4-1. Operation Temperature : -40℃~105℃

DRAWN	Emily Suen	APP'D	Ku Chou	UNIT	mm	TOLERANCE		广东科斯达电子科技有限公司 GUANG DONG KE SI DA ELECTRONIC TECHNOLOGY CO., LTD.	TITLE	M12 T-CODING (M) 前鎖板(PG9) 焊線式			SHEET	
CHK'D	Ku Chou			SCALE	1:1	.x ±0.20 .xx ±0.10 .xxx ±0.05 .xxxx ±0.03 ANGULA ±1°			PART NO.	SEE TABLE A	DWG NO.	QC9611	VERSION	