

CUSTOMER DRAWING

REV.	DESCRIPTION	APPROVED BY	DATE	ECN NO.
A	RELEASE	Ku Chou	28/05/20'	
B				
C				

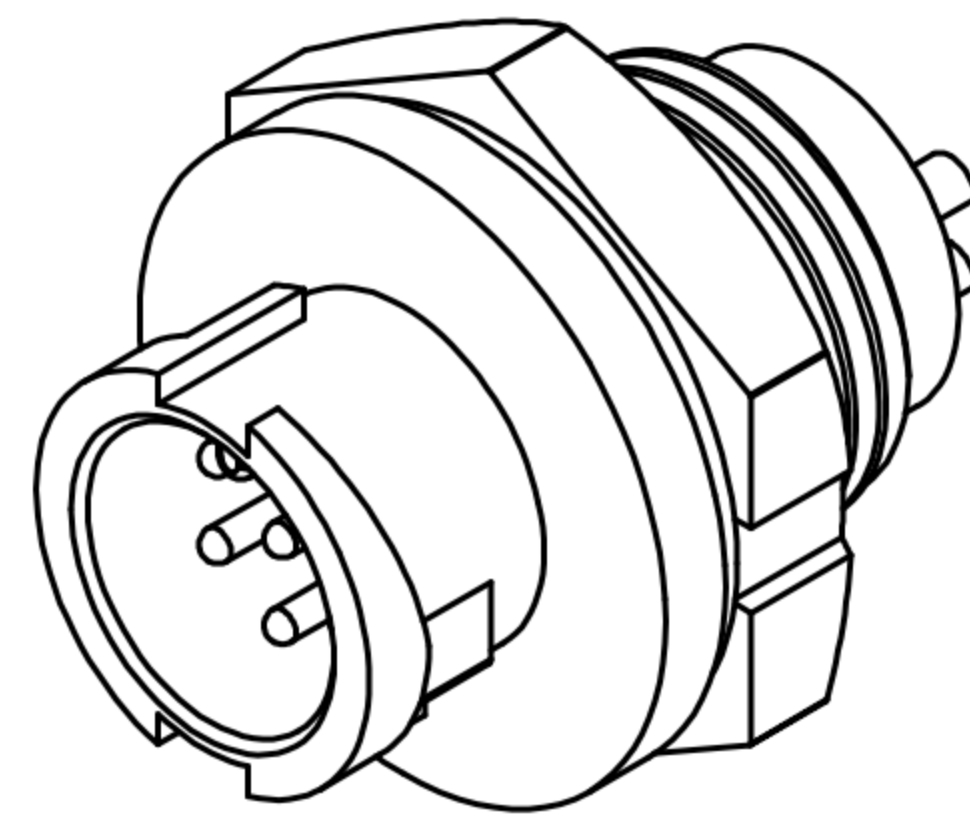
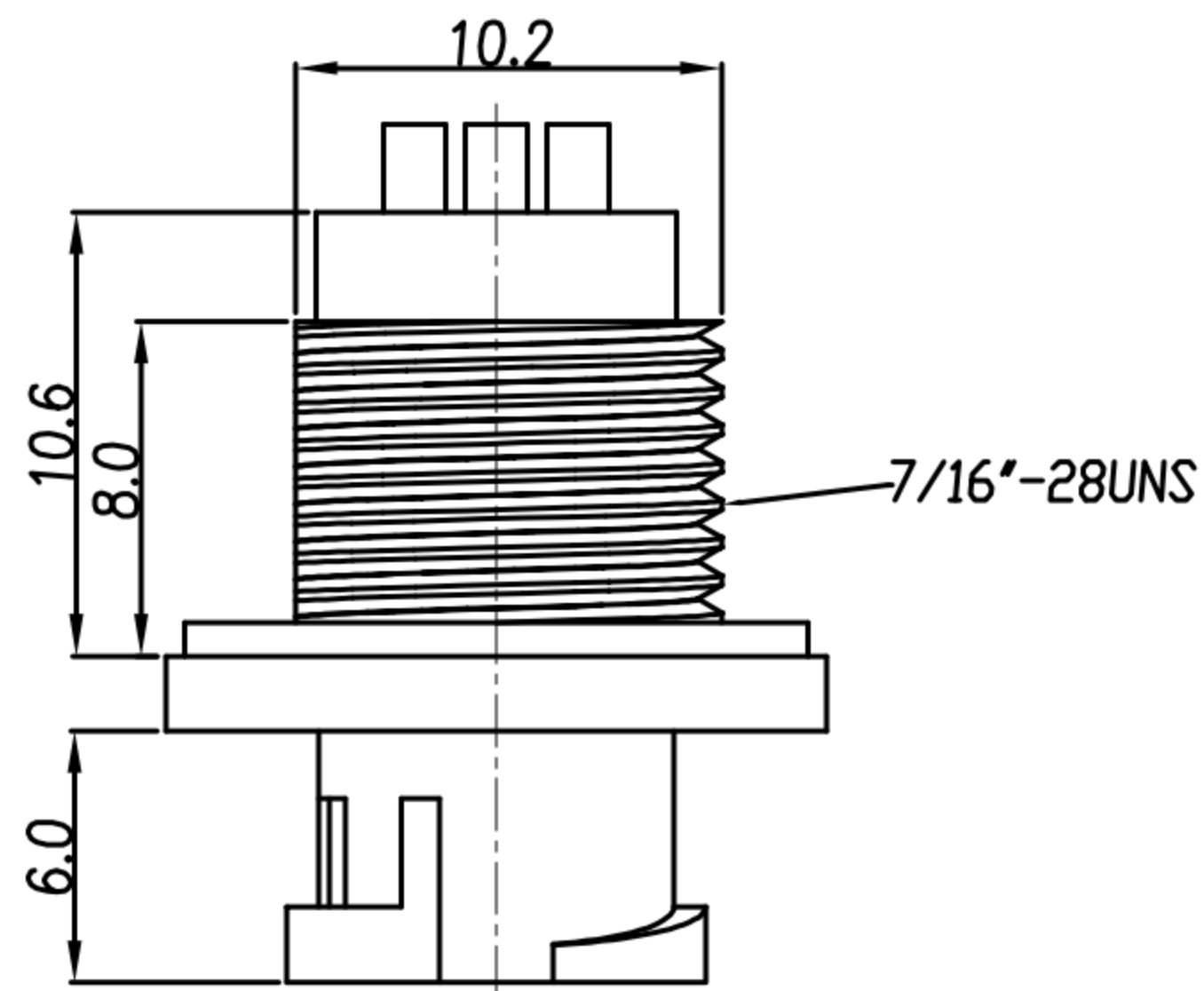
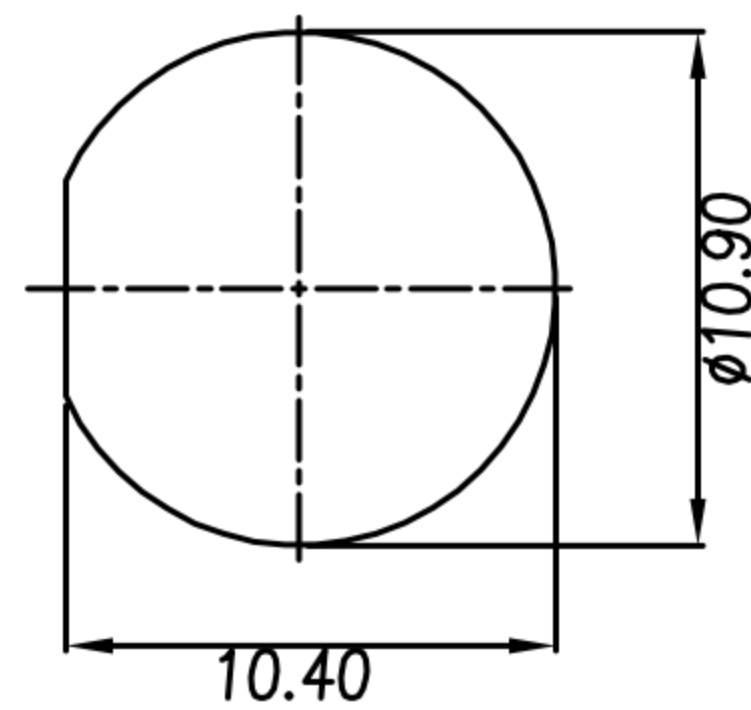
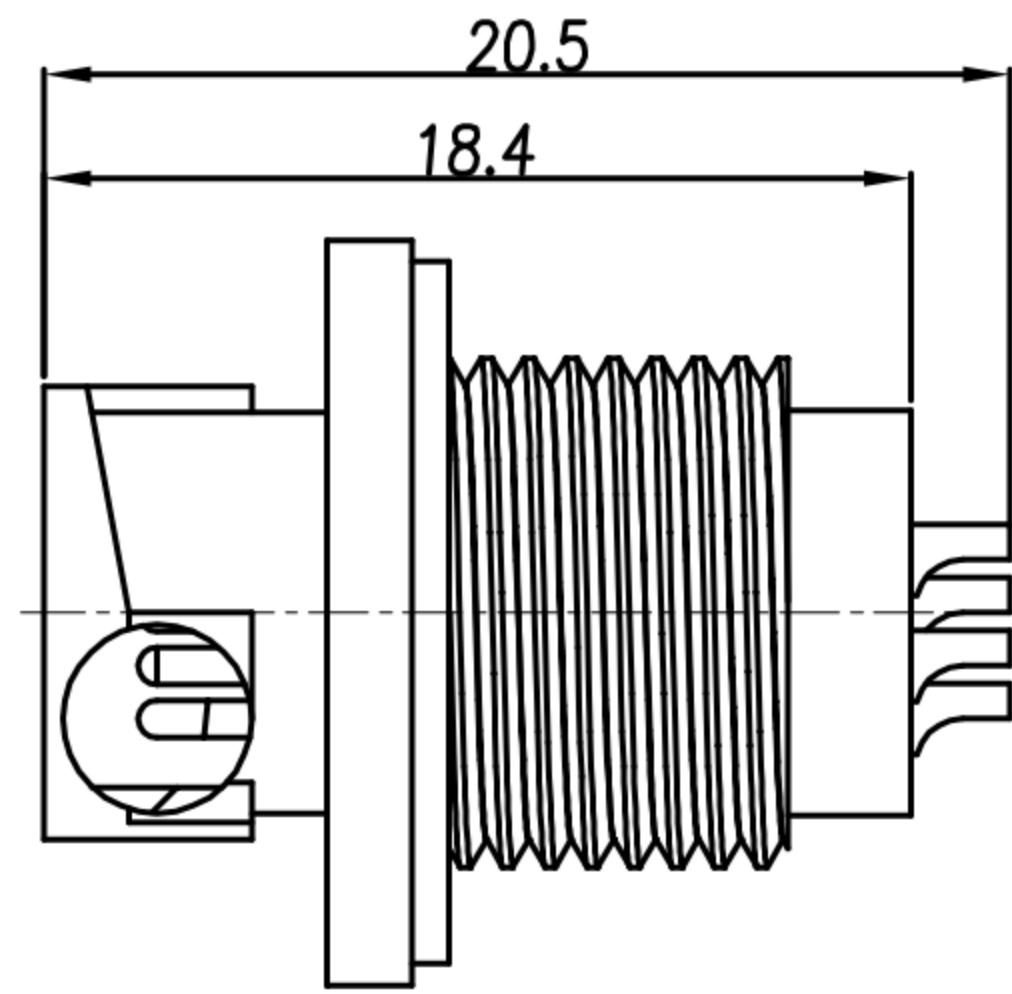
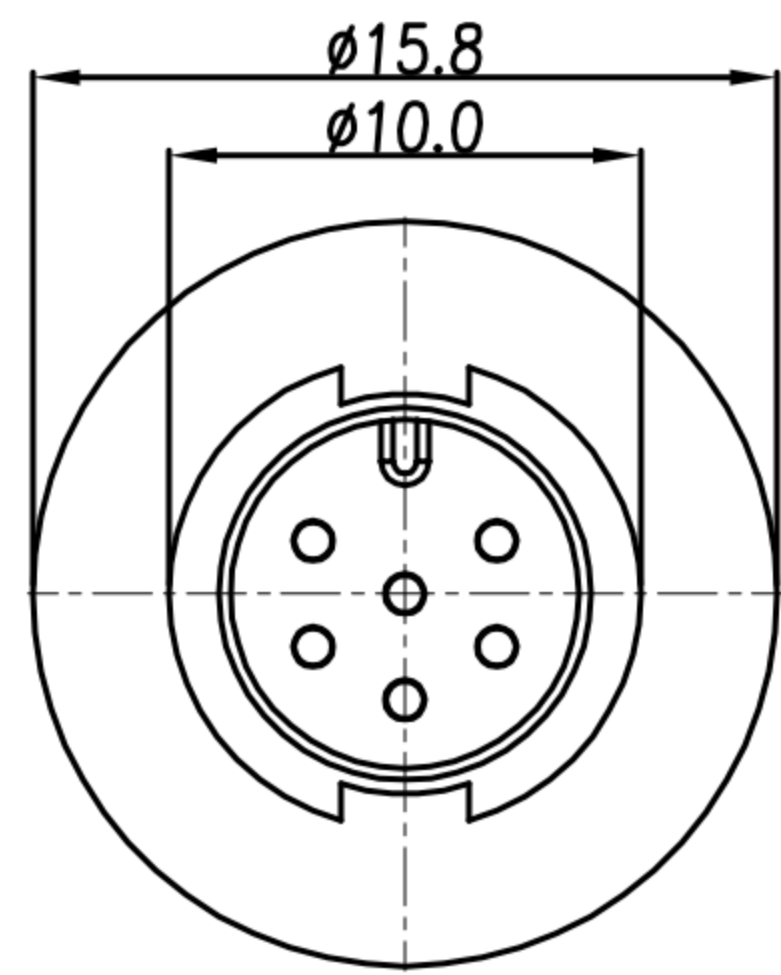

TABLE A

4 PIN	5 PIN	6 PIN
WP-04M2-215-11	WP-05M2-168-11	WP-06M2-76-11

PIN ASSIGMENTS
FRONT VIEW



RECOMMENDED PANEL CUT-OUT

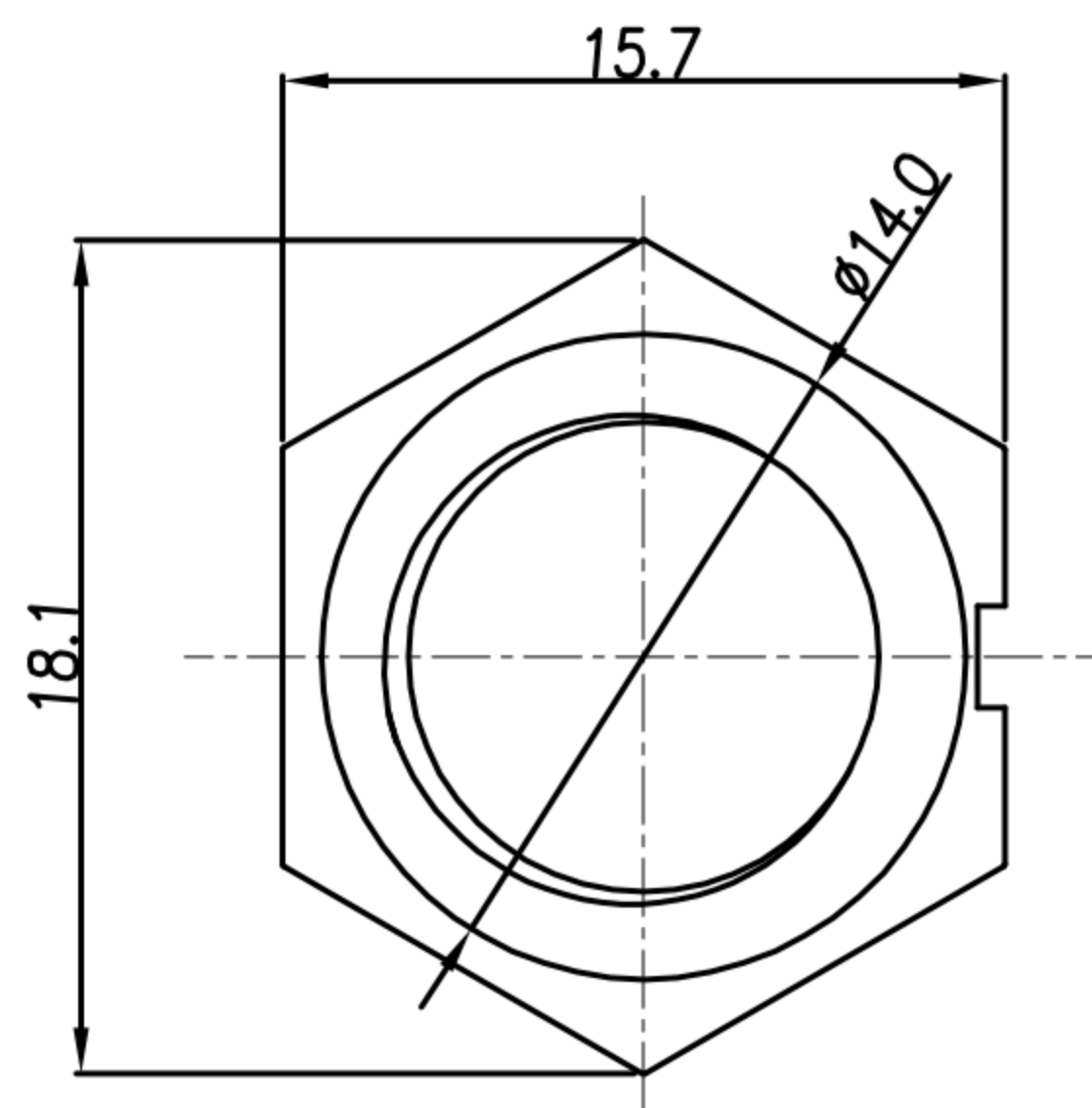

HEX NUT



- MATERIAL :
 - HOUSING : PA66
 - CONTACT : BRASS
 - GASKET : SILICONE
 - HEX NUT : PA66
- FINISH :
 - CONTACT : GOLD FLASH PLATED.
- ELECTRICAL SPECIFICATION :
 - Rated current : 2A
 - Rated voltage : 250V
 - Water proof : IP67
- Environmental :
 - Operation Temperature : -40°C~105°C

DRAWN	Emily Suen	APP'D	Ku Chou	UNIT	mm	TOLERANCE		广东科斯达电子科技有限公司 GUANG DONG KE SI DA ELECTRONIC TECHNOLOGY CO., LTD.	TITLE	WP A SIZE M CONN M PIN REAR FASTENED (LOCK BAYONET) SOLDER TYPE			SHEET	A
CHK'D	Ku Chou			SCALE	1:1	.x ±0.20 .xx ±0.10 .xxx ±0.05 .xxxx ±0.03 ANGULA ±1°			PART NO.	SEE TABLE A	DWG NO.	QC9762	VERSION	