

CUSTOMER DRAWING

REV.	DESCRIPTION	APPROVED BY	DATE	ECN NO.
B	改變油封材質&PIN針扣環.	Fido Weng	01/12/11'	ECN-11047
C	新增料號	KU	11/01/19'	
D	新增料號	KU	28/07/20'	

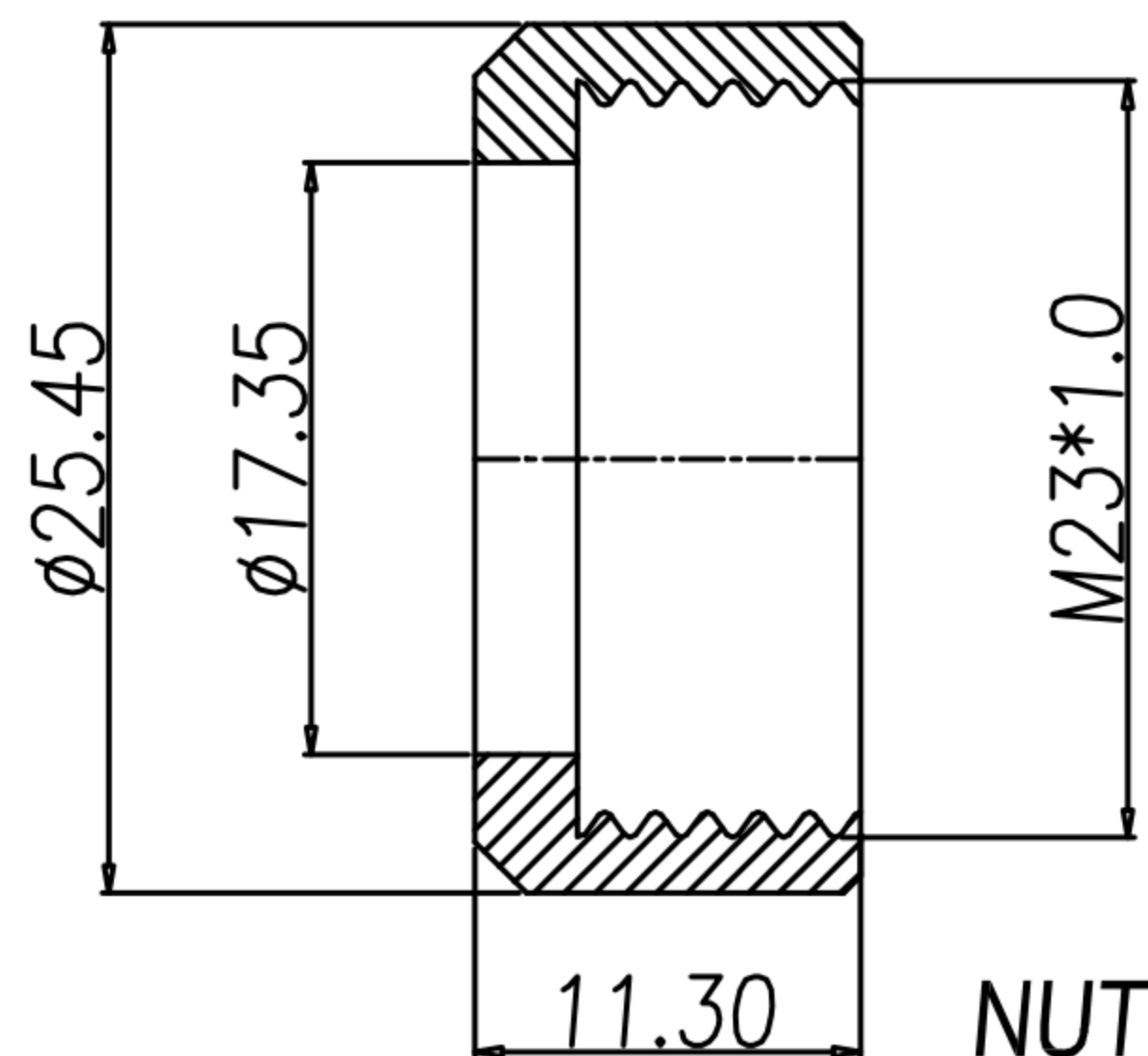
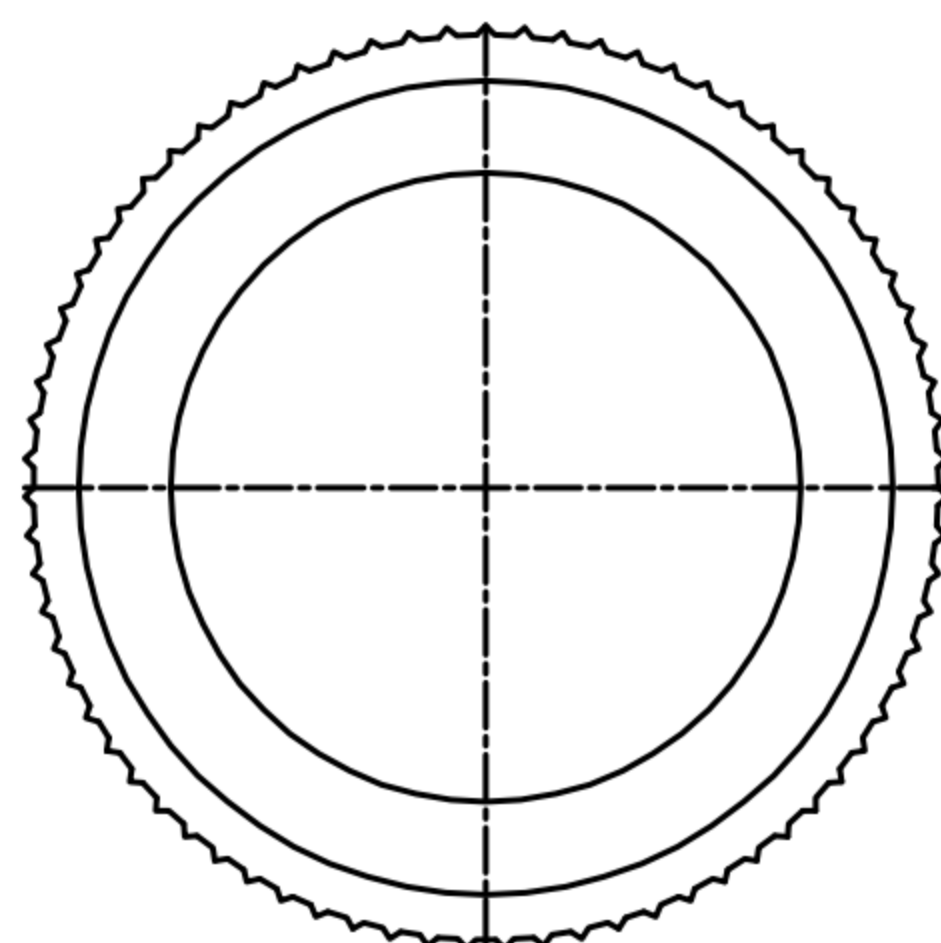
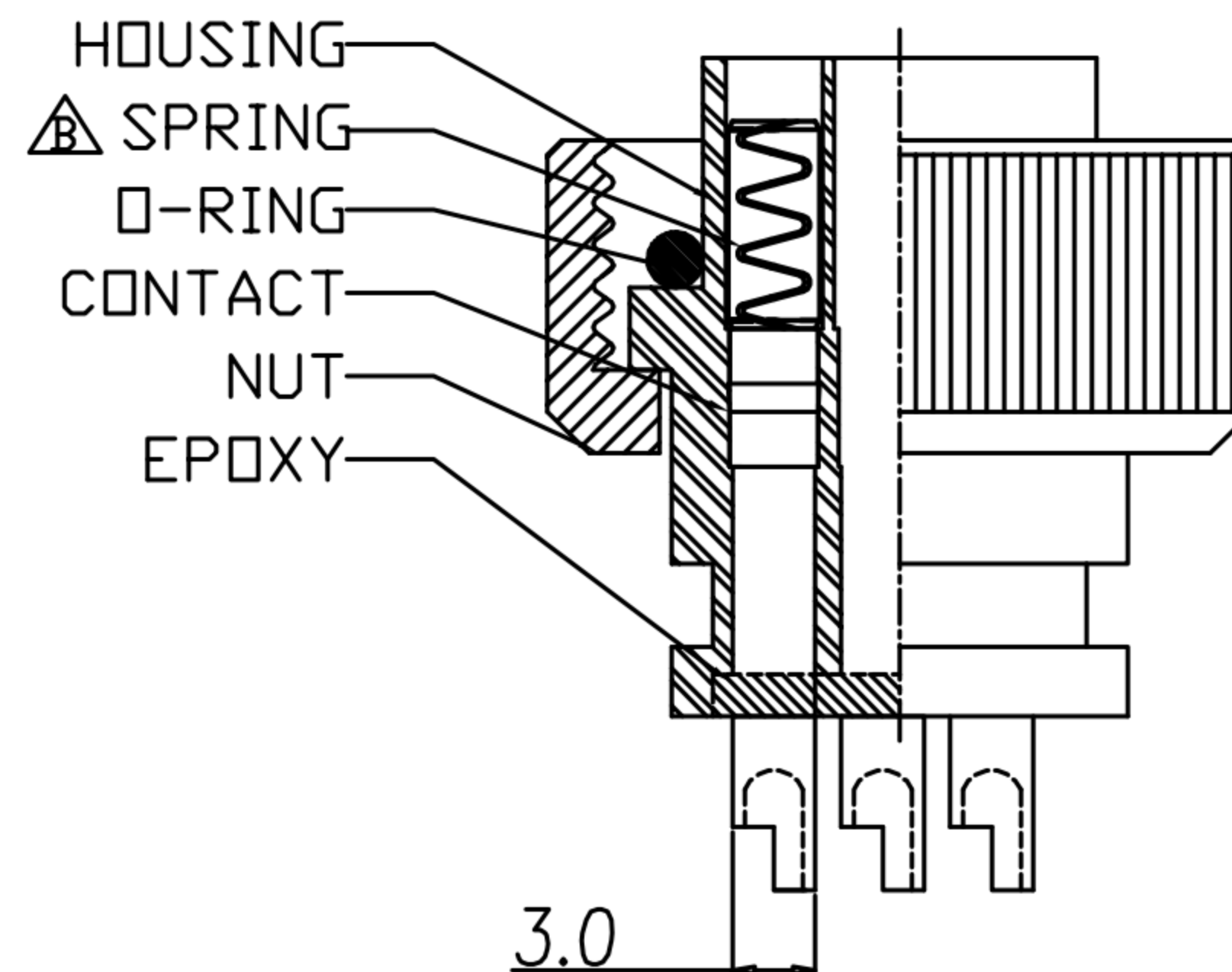
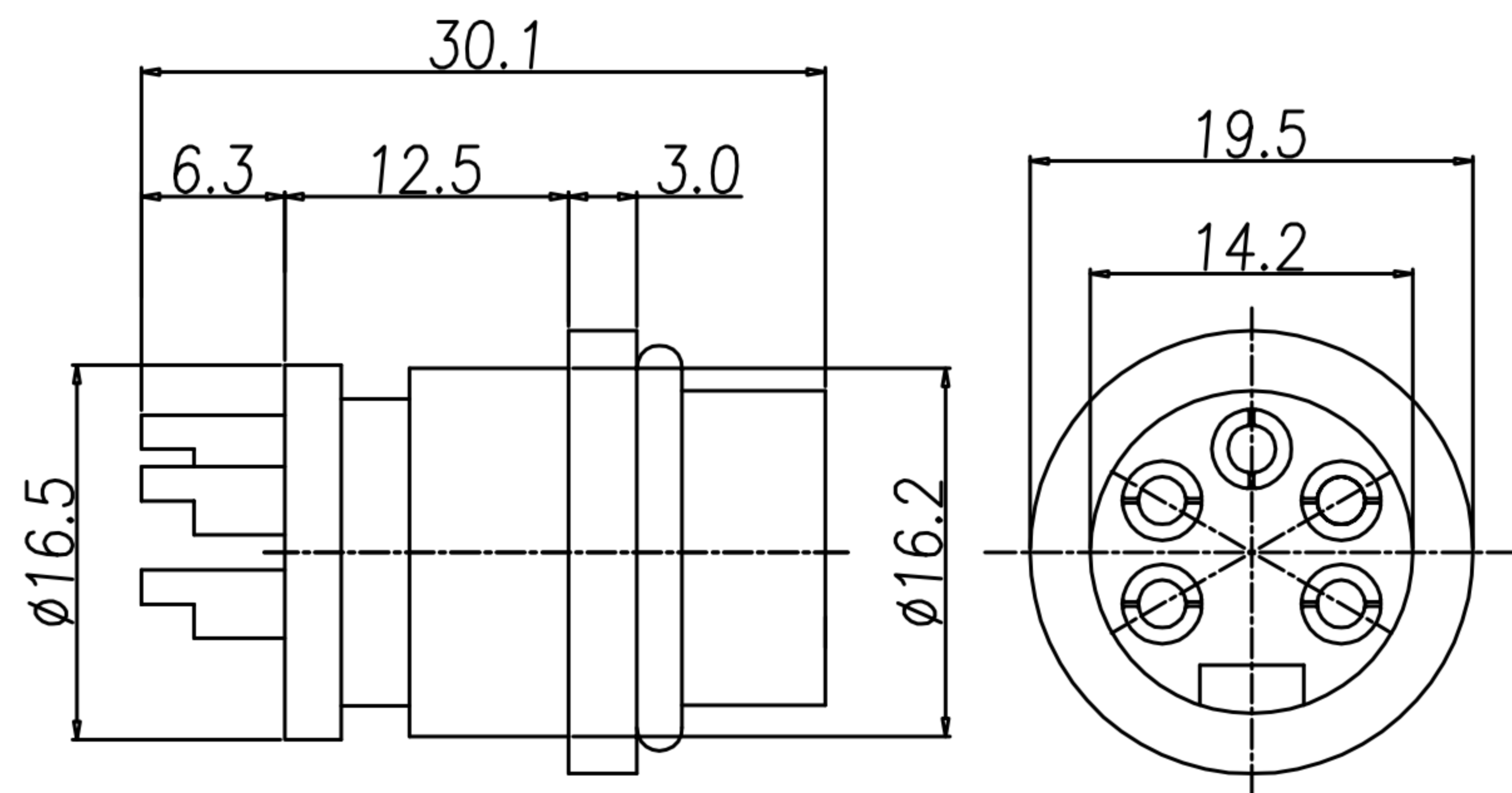

TABLE A

WP-05F2-39	30u" GOLD PLATED	WP-05F2-195-11	GOLD FLASH
WP-04F2-211-11	30u" GOLD PLATED	WP-04F2-262-11	GOLD FLASH
WP-03F2-109-11	30u" GOLD PLATED	WP-03F2-151-11	GOLD FLASH
P/N	CONTACT FINISH	P/N	CONTACT FINISH

TABLE A

3PIN	4PIN	5PIN

- MATERIAL :
 - HOUSING : PBT UL94V-0 ; COLOR : YELLOW
 - CONTACT : BRASS
 - SPRING : PHOSPHOR BRONZE
 - NUT : BRASS
 - O-RING : EPDM ; COLOR : BLACK
- FINISH :
 - CONTACT : SEE TABLE A
UNDER PLATE : NICKEL
 - SPRING : MATTE TIN PLATED
 - NUT : NICKEL PLATED
- ELECTRICAL SPECIFICATION :
 - Rated current : 20A
 - Rated Voltage : 250V
 - Water proof : IP67
- Environmental :
 - Operation Temperature : -40℃~85℃

DRAWN	Ku Chou	APP'D	Emily Suen	UNIT	mm	TOLERANCE		广东科斯达电子科技有限公司 GUANG DONG KE SI DA ELECTRONIC TECHNOLOGY CO., LTD.	TITLE	防水頭M23 5PIN(F)杯口線端			SHEET	1
CHK'D	Emily Suen			SCALE	1:1	.x ±0.25 .xx ±0.20 .xxx ±0.10 .xxxx ±0.03 ANGULA ±1°			PART NO.	SEE TABLE A	DWG NO.	QC3943	VERSION	D