

CUSTOMER DRAWING

REV.	DESCRIPTION	APPROVED BY	DATE	ECN NO.
A	RELEASE	LEO	10/02/23*	
B				
C				
D				

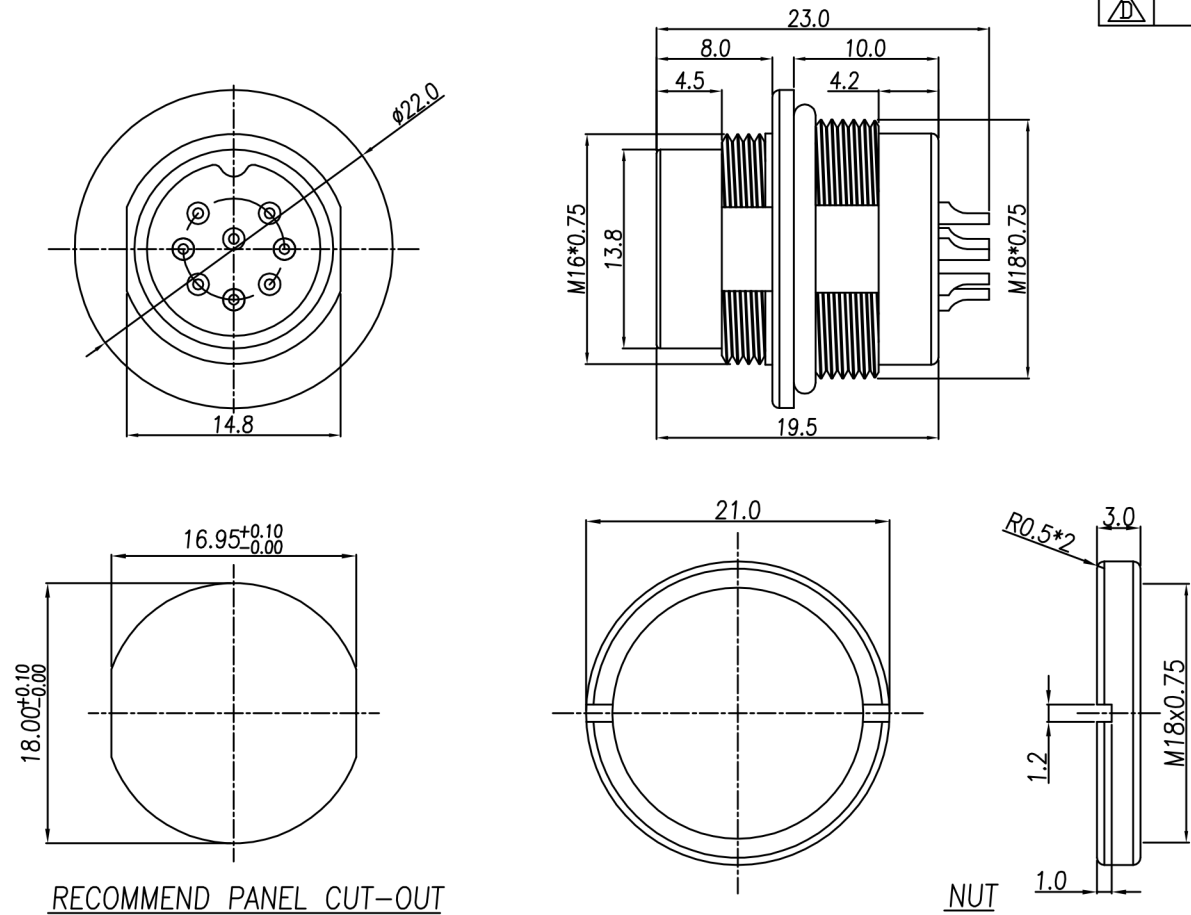

- MATERIAL :
 - HOUSING : PA66 ; COLOR : BLACK.
 - CONTACT : BRASS
 - NUT : BRASS
 - O-RING : EPDM ; COLOR : BLACK
 - SHELL : BRASS.
- FINISH :
 - CONTACT : GOLD FLASH MICRO INCHES MIN.
UNDER PLATE : NICKEL
 - NUT : NICKEL PLATED
 - SHELL : NICKEL PLATED
- ELECTRICAL SPECIFICATION :
 - Rated current : 5A
 - Rated Voltage : 250V
 - Water proof: IP67
- Environmental :
 - Operation Temperature : $-40^{\circ}\text{C} \sim 85^{\circ}\text{C}$

RECOMMEND PANEL CUT-OUT

DI-03M2-18-11	DI-04M2-26-11	DI-05M2-27-11	DI-06M2-23-11	DI-07M2-26-11	DI-07M2-27-11	DI-08M2-25-11

DRAWN	LEO	APPEND	Emily Suen	UNIT	mm	TOLERANCE			广东科斯达电子科技有限公司 GUANG DONG KE SI DA ELECTRONIC TECHNOLOGY CO., LTD.	TITLE	DIN M16 (M) 後鎖M18焊線式			SHEET	
CHK'D	Emily Suen			SCALE	1:1					PART NO.	SEE TABLE A	DWG NO.	QC10586	VERSION	