

CUSTOMER DRAWING

REV.	DESCRIPTION	APPROVED BY	DATE	ECN NO.
A	RELEASE	Ku Chou	16/07/18'	
B				
C				

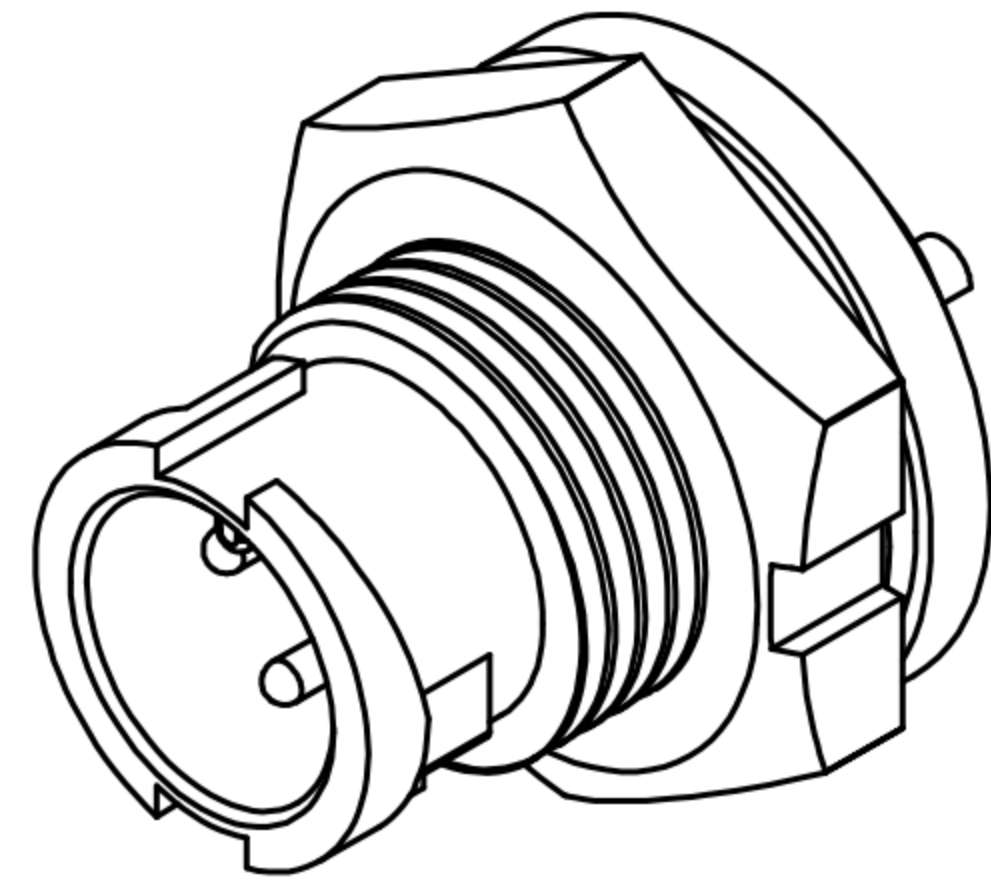
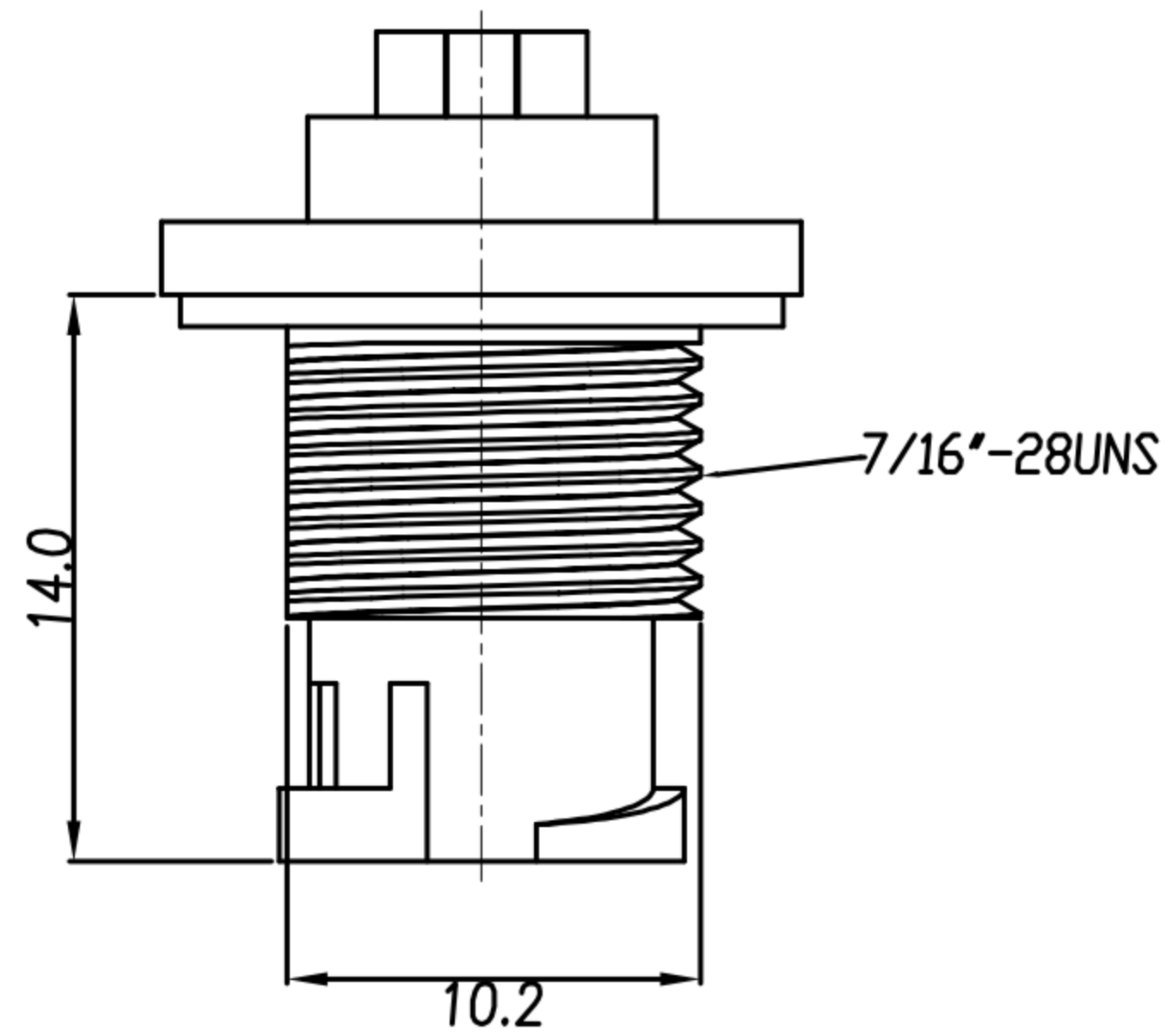
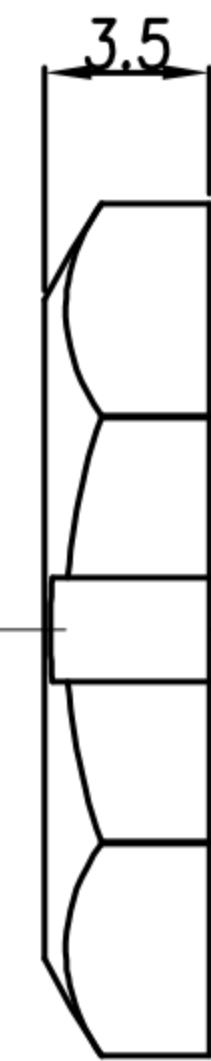
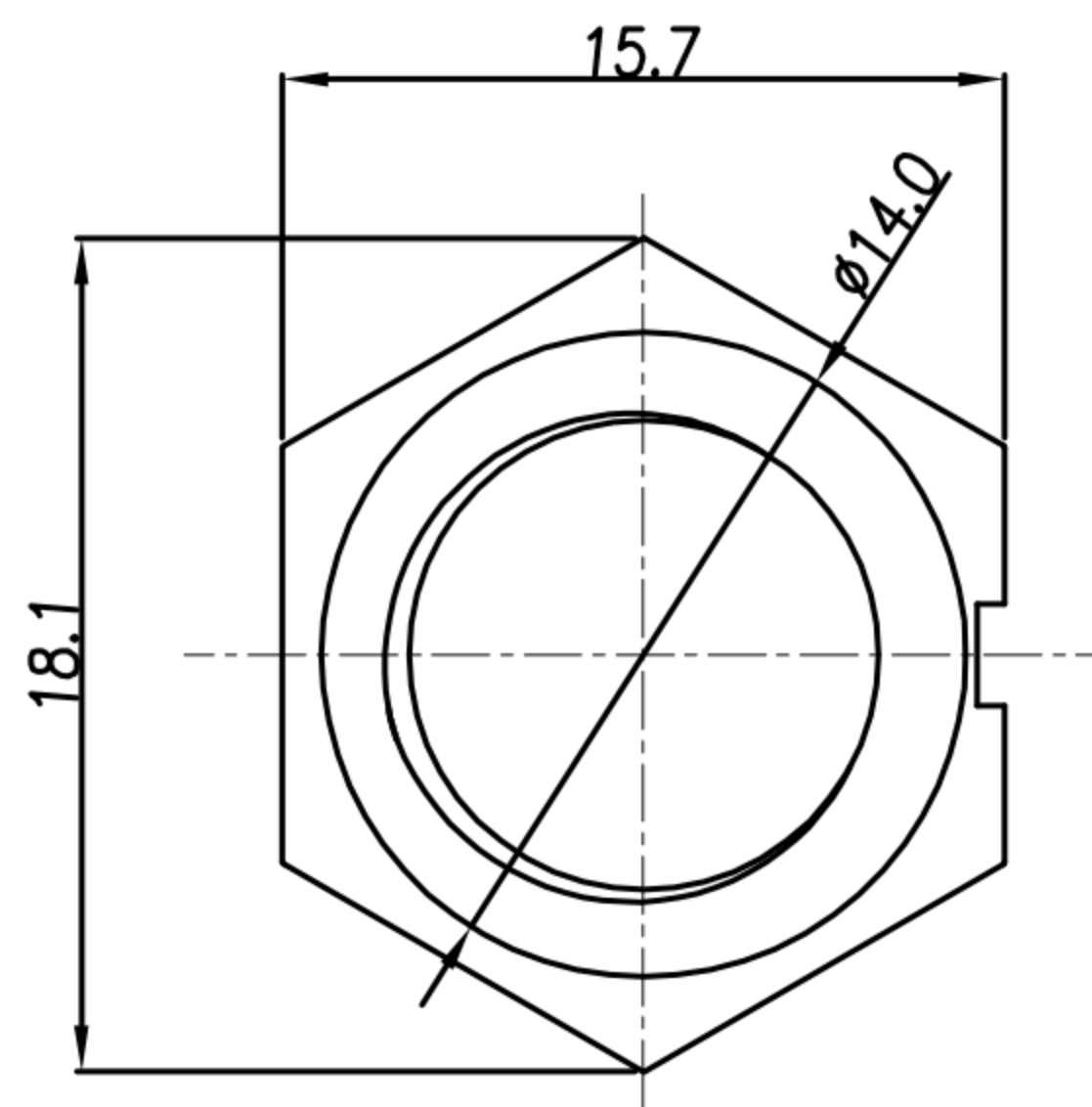
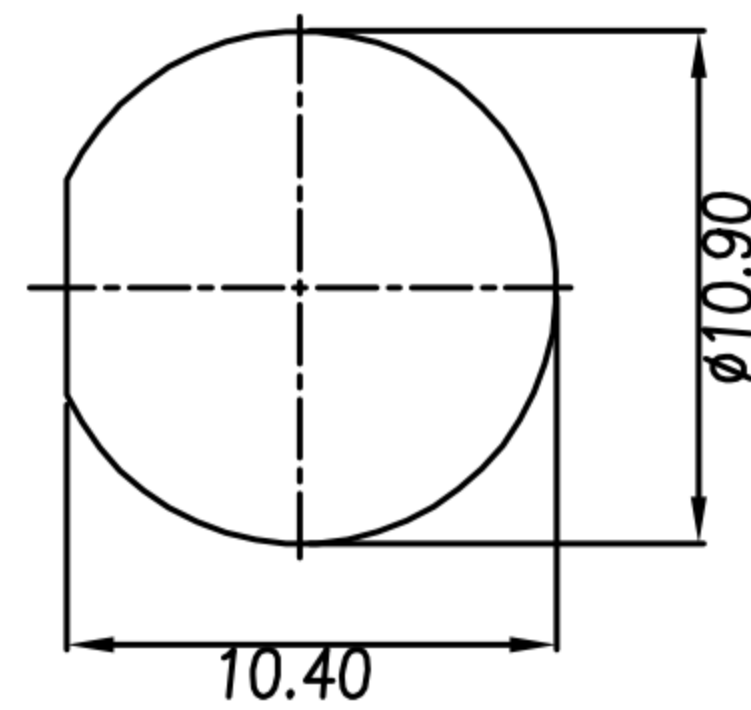
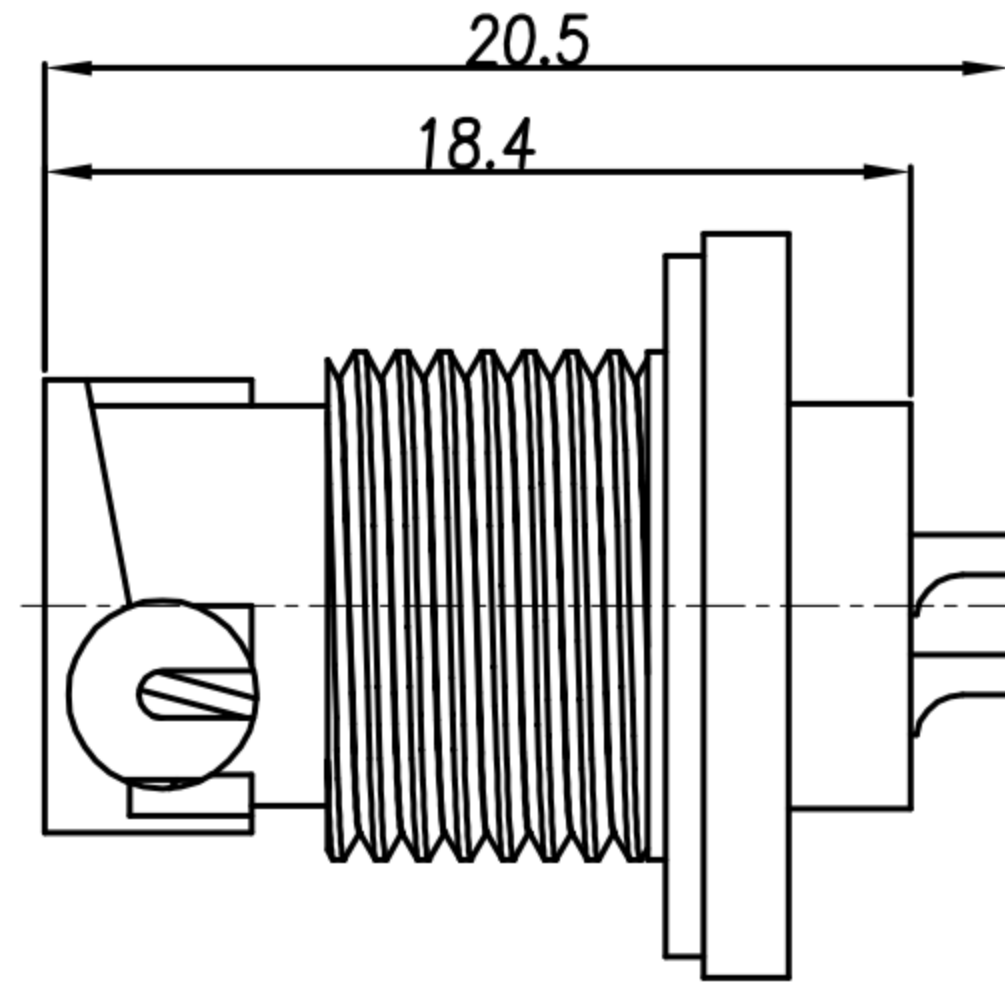
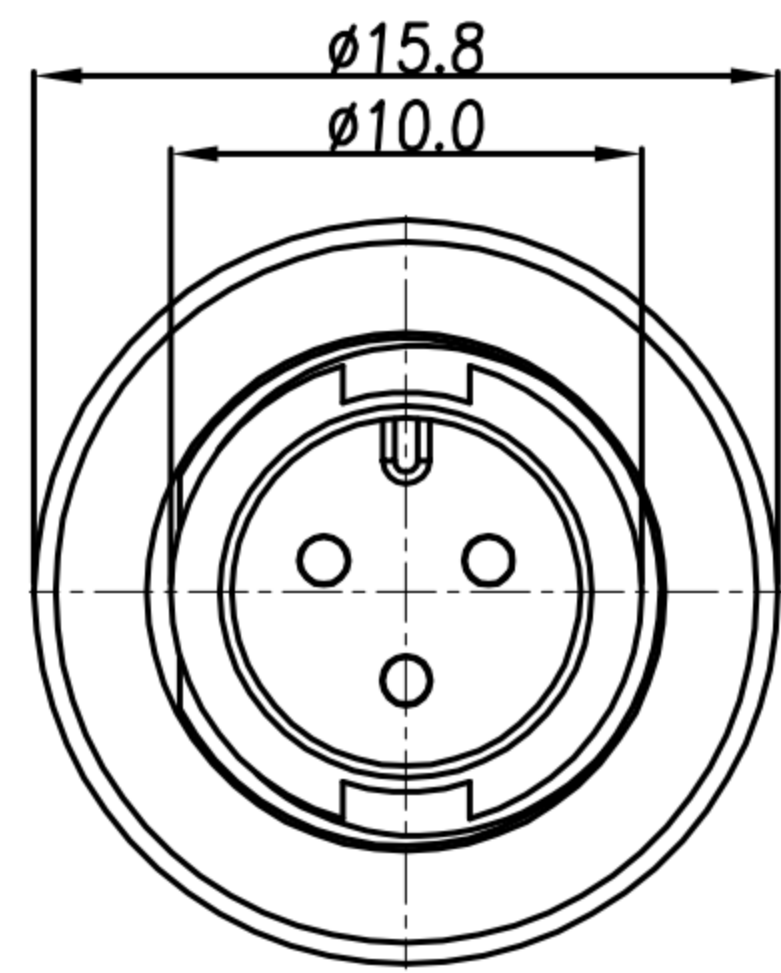

TABLE A

2 PIN	3 PIN
WP-02M1-01-11	WP-03M1-01-11

PIN ASSIGMENTS
FRONT VIEW



- MATERIAL :
 - HOUSING : PA66
 - CONTACT : BRASS
 - GASKET : SILICONE
 - HEX NUT : PA66
- FINISH :
 - CONTACT : GOLD FLASH PLATED.
- ELECTRICAL SPECIFICATION :
 - Rated current : 5A
 - Rated voltage : 250V
 - Water proof : IP67
- Environmental :
 - Operation Temperature : -40°C~105°C

RECOMMENDED PANEL CUT-OUT

HEX NUT

DRAWN	Emily Suen	APP'D	Ku Chou	UNIT	mm	TOLERANCE		广东科斯达电子科技有限公司 GUANG DONG KE SI DA ELECTRONIC TECHNOLOGY CO., LTD.	TITLE	WP A SIZE M CONN M PIN FRONT FASTENED (LOCK BAYONET) SOLDER TYPE			SHEET	
CHK'D	Ku Chou			SCALE	1:1				PART NO.	SEE TABLE A	DWG NO.	QC8922	VERSION	