

CUSTOMER DRAWING

REV.	DESCRIPTION	APPROVED BY	DATE	ECN NO.
△A	RELEASE	Ku Chou	20/07/18*	
△B	CHANGE CLAMP RING MATERIAL	Ku Chou	31/10/18*	
△C				

TABLE A

6 PIN	7 PIN	8 PIN	
WP-06M2-64-11	WP-07M2-21-11	WP-08M2-79-11	
2 PIN	3 PIN	4 PIN	5 PIN
WP-02M2-56-11	WP-03M2-96-11		

PIN ASSIGNMENTS  
FRONT VIEW

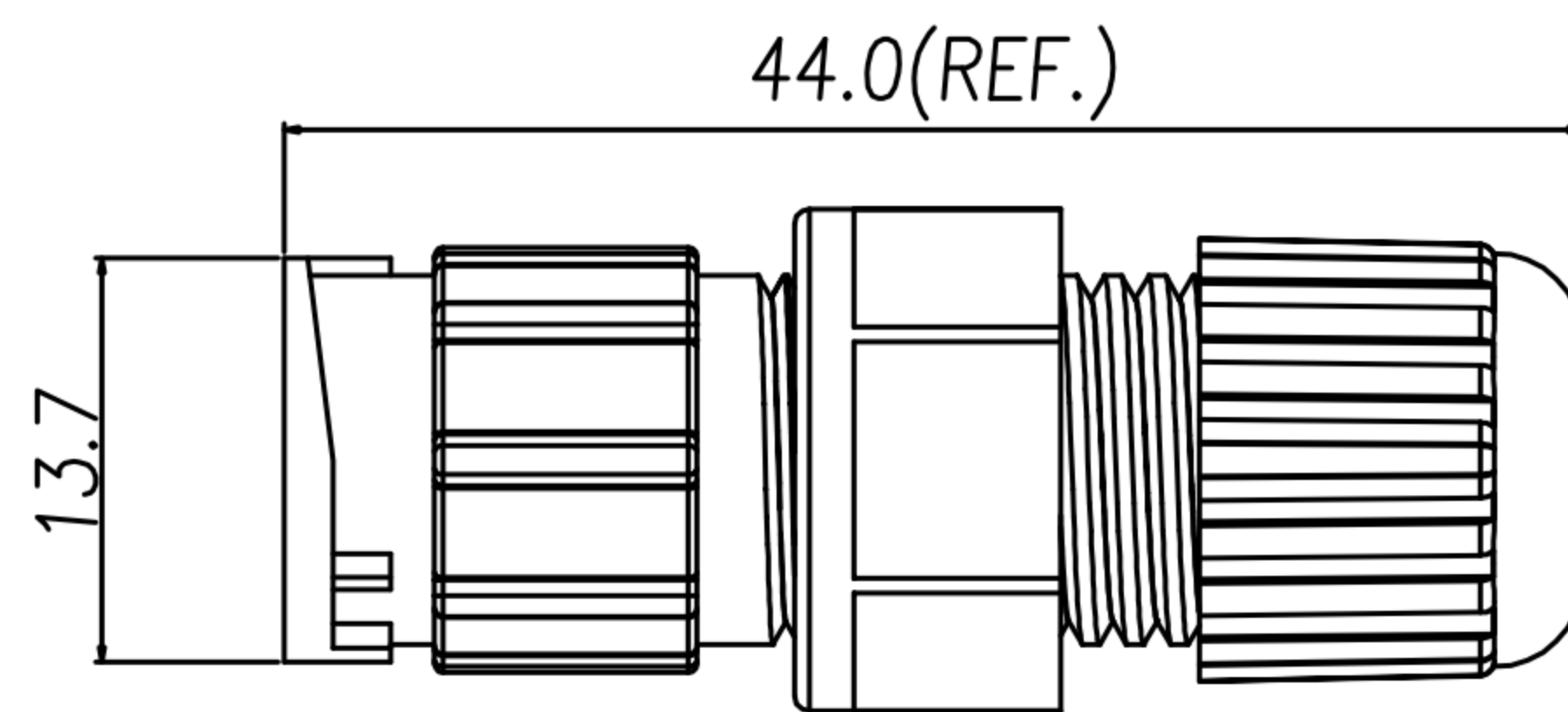
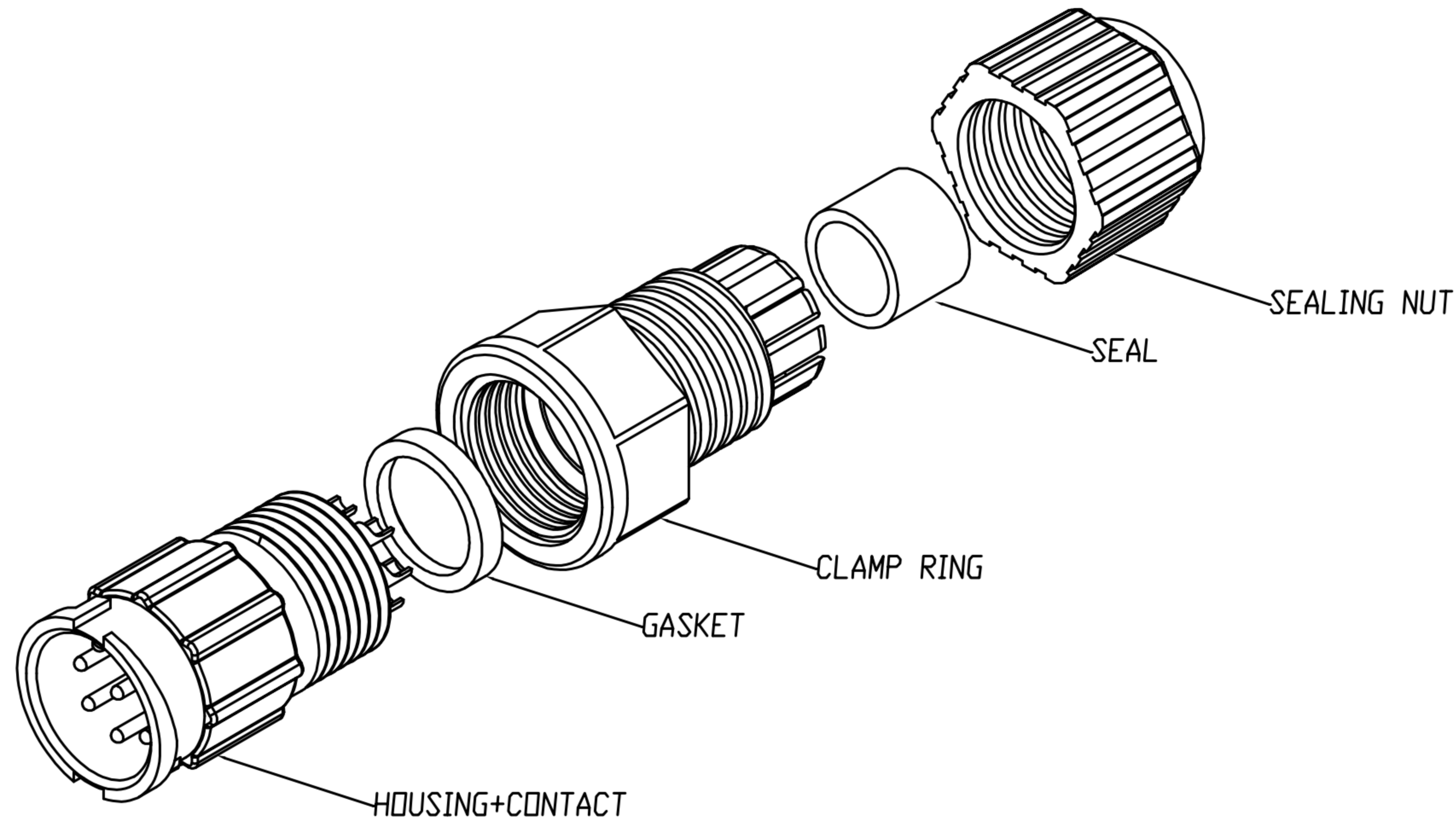

- MATERIAL :
  - 1-1. HOUSING : PA66
  - 1-2. CONTACT : BRASS
  - 1-3. GASKET : SILICONE
  - 1-4. CLAMP RING : PA66
  - 1-5. SEAL : SILICONE △B
  - CABLE OD $\phi$ 4.5mm ~6.5mm
  - 1-6. SEALING NUT : PA66
- FINISH :
  - 2-1. CONTACT : GOLD FLASH PLATED.
- ELECTRICAL SPECIFICATION :
  - 3-1. Rated current : 5A
  - 3-2. Rated voltage : 250V
  - 3-3. Water proof : IP67
- Environmental :
  - 4-1. Operation Temperature : -40 $^{\circ}$ C~105 $^{\circ}$ C

DRAWN	Emily Suen	APP'D	Ku Chou	UNIT	mm	TOLERANCE		广东科斯达电子科技有限公司 GUANG DONG KE SI DA ELECTRONIC TECHNOLOGY CO., LTD.	TITLE	WP (M) (LOCK) B SIZE ASSEMBLY TYPE(5A)			SHEET	1
CHK'D	Ku Chou			SCALE	1:1	.x $\pm 0.20$ .xx $\pm 0.10$ .xxx $\pm 0.05$ .xxxx $\pm 0.03$ ANGULA $\pm 1^{\circ}$			PART NO.	SEE TABLE A	DWG NO.	QC8640	VERSION	