

CUSTOMER DRAWING

REV.	DESCRIPTION	APPROVED BY	DATE	ECN NO.
A	RELEASE	Fido Weng	25/04/17*	
B				
C				

- MATERIAL :
 - HOUSING : PA66 UL94V-0 ; COLOR : BLACK
 - CONTACT : BRASS
 - NUT : SEE TABLE A
 - O-RING : EDPM
 - SHELL : SEE TABLE A
- FINISH :
 - CONTACT : 10 MICRO INCHES MIN. GOLD PLATED
UNDER PLATE : NICKEL
 - NUT : SEE TABLE A
 - SHELL : SEE TABLE A
- ELECTRICAL SPECIFICATION :
 - Rated current : 16A
 - Rated Voltage : 63V
 - Water proof: IP67/68
- Environmental :
 - Operation Temperature : -40°C~105°C

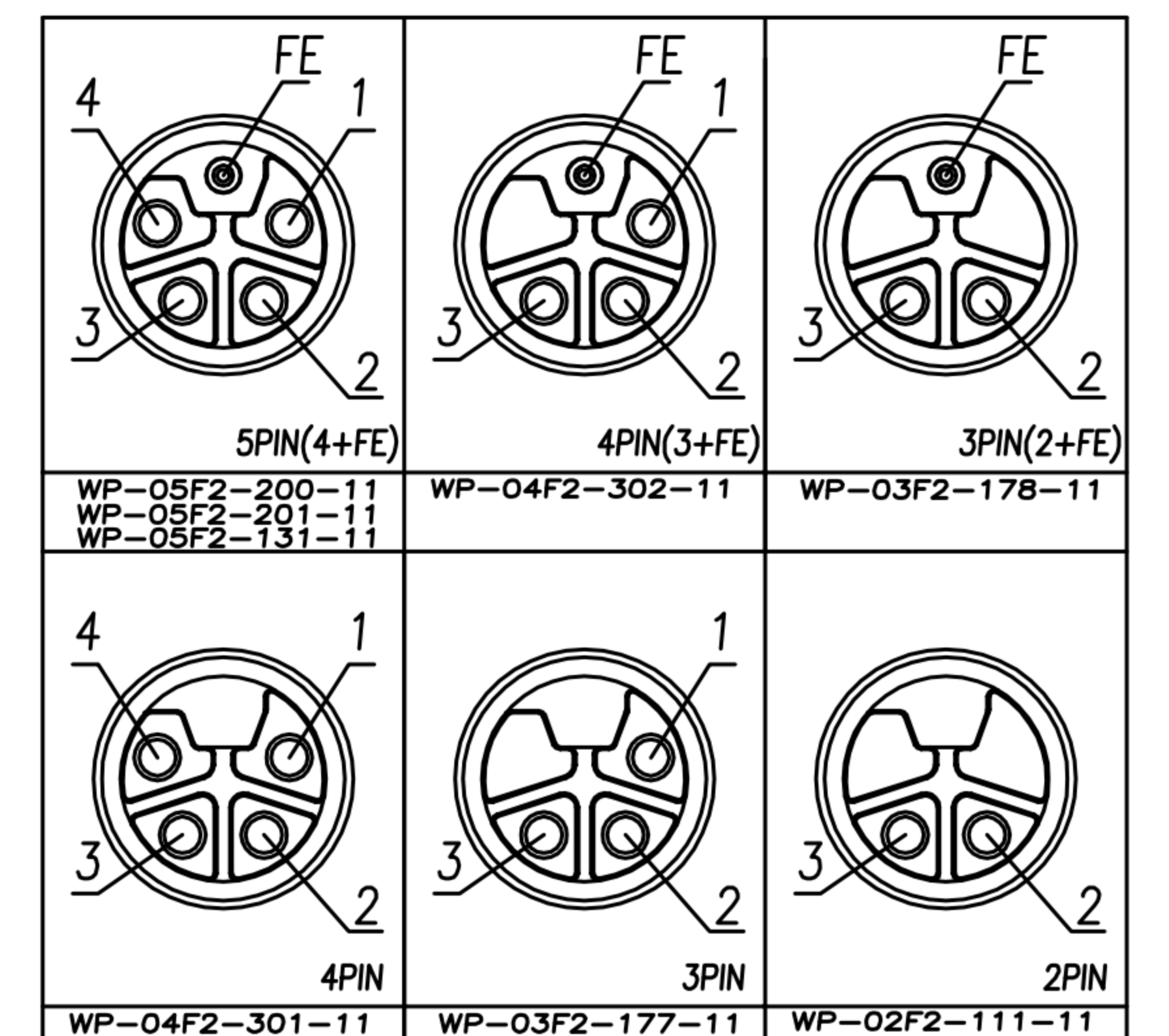
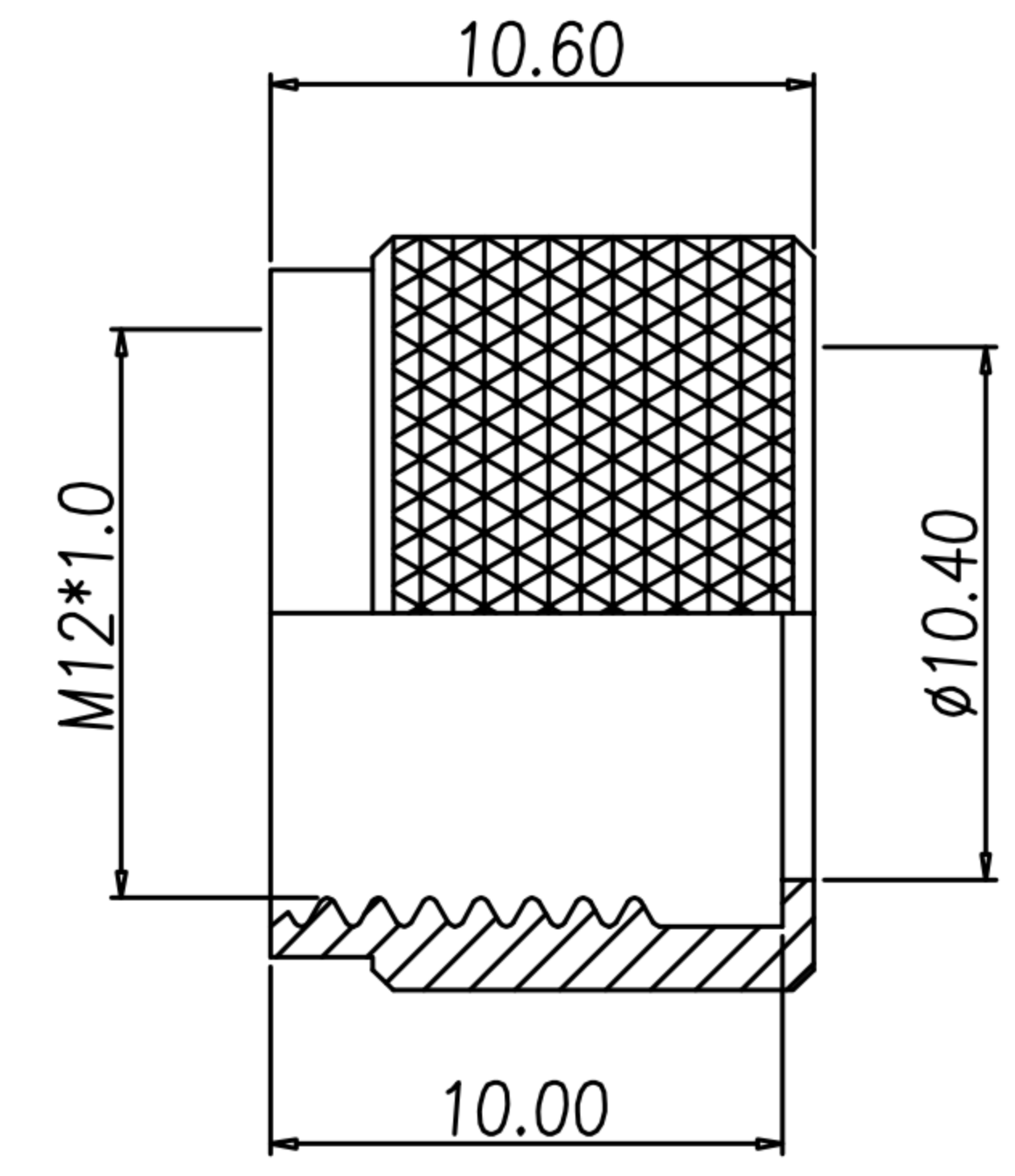
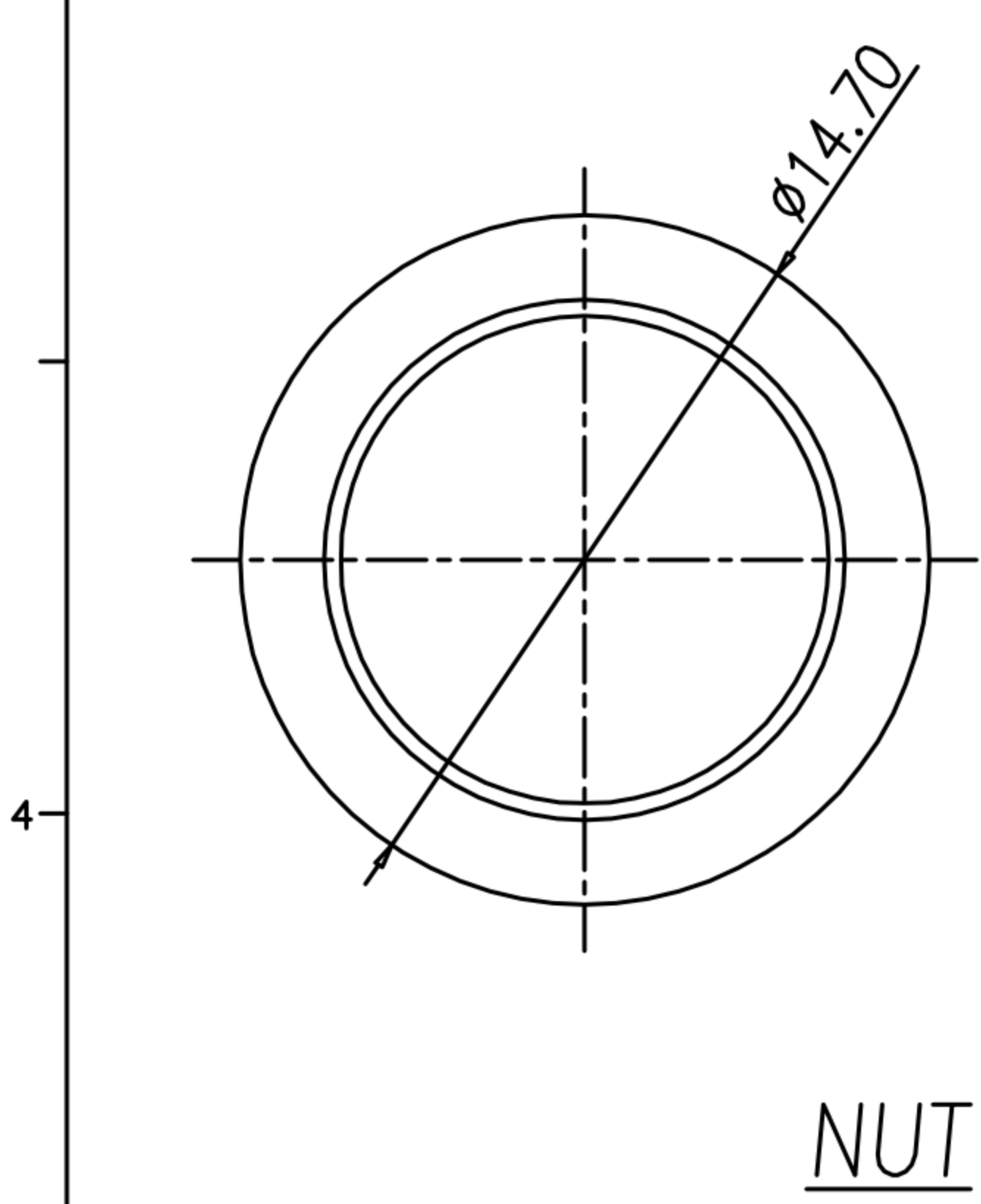
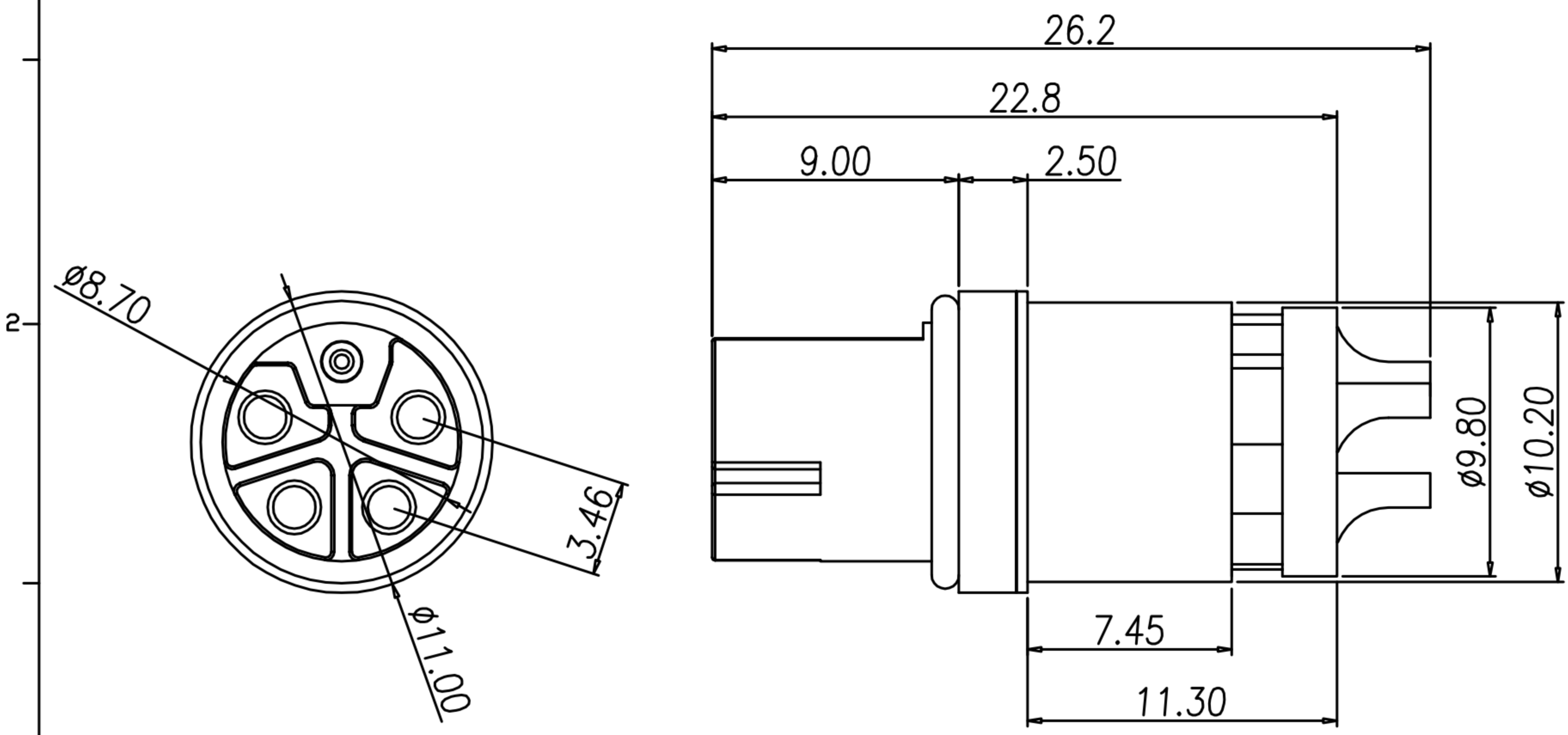

TABLE A

PART No.	MATERIAL(SHELL)	FINISH(SHELL)	MATERIAL(NUT)	FINISH(NUT)
WP-05F2-200-11	STAINLESS STEEL 316	PASSIVATION	STAINLESS STEEL 316	PASSIVATION
WP-05F2-201-11	BRASS	BRIGHT TIN PLATED	STAINLESS STEEL 316	PASSIVATION
WP-05F2-131-11	BRASS	BRIGHT TIN PLATED	BRASS	NICKEL PLATED
WP-04F2-302-11	BRASS	BRIGHT TIN PLATED	BRASS	NICKEL PLATED
WP-04F2-301-11	BRASS	BRIGHT TIN PLATED	BRASS	NICKEL PLATED
WP-03F2-178-11	BRASS	BRIGHT TIN PLATED	BRASS	NICKEL PLATED
WP-03F2-177-11	BRASS	BRIGHT TIN PLATED	BRASS	NICKEL PLATED
WP-02F2-111-11	BRASS	BRIGHT TIN PLATED	BRASS	NICKEL PLATED