

CUSTOMER DRAWING

REV.	DESCRIPTION	APPROVED BY	DATE	ECN NO.
A	RELEASE	Ku Chou	28/05/20'	
B				
C				

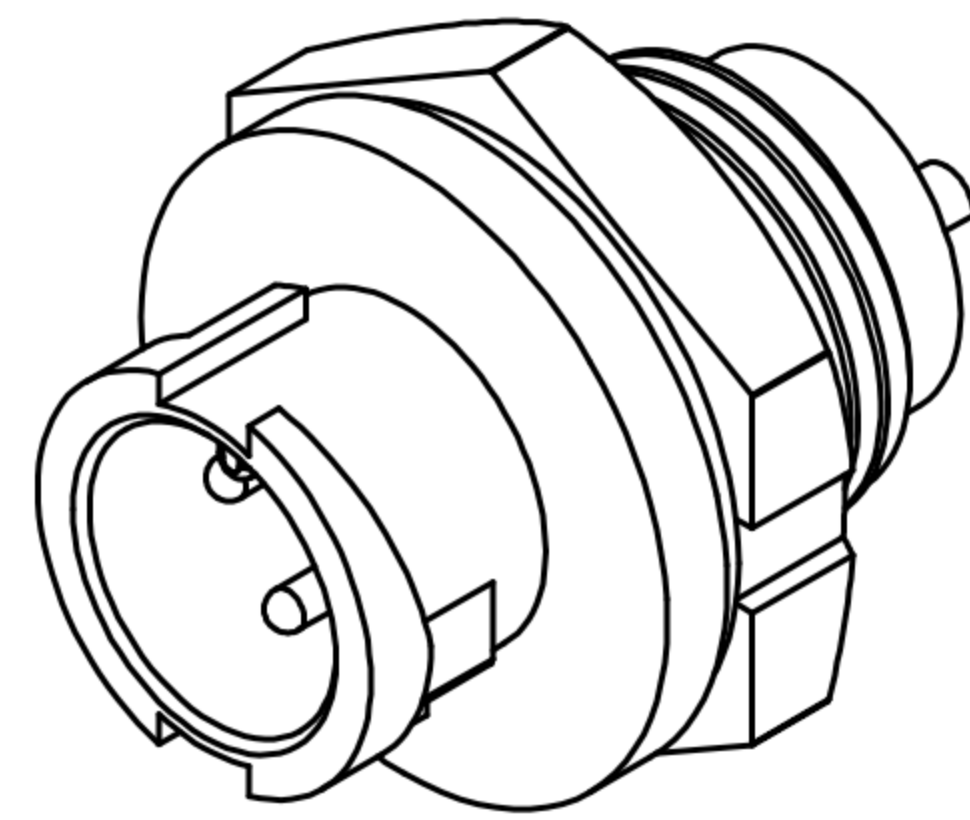
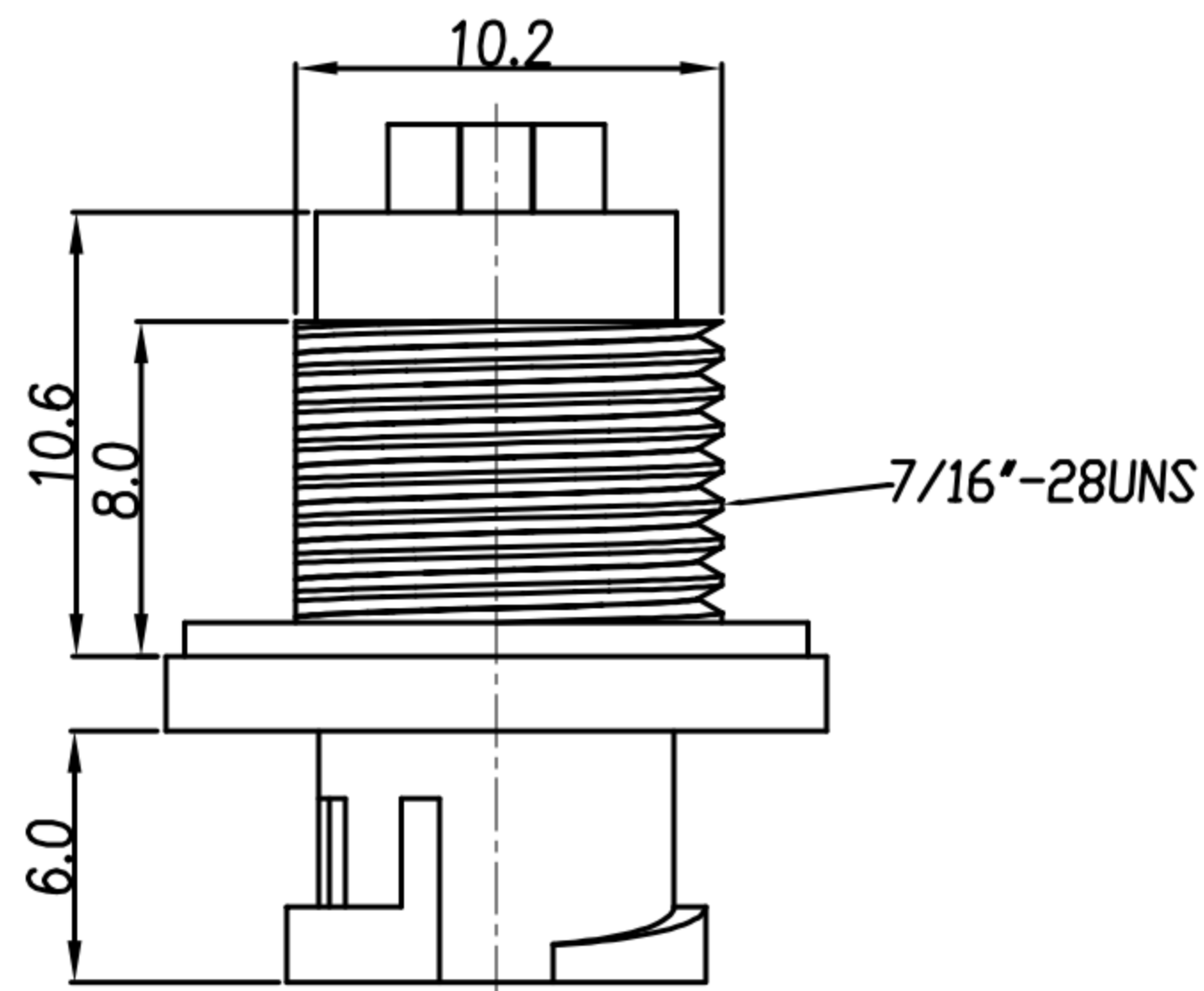
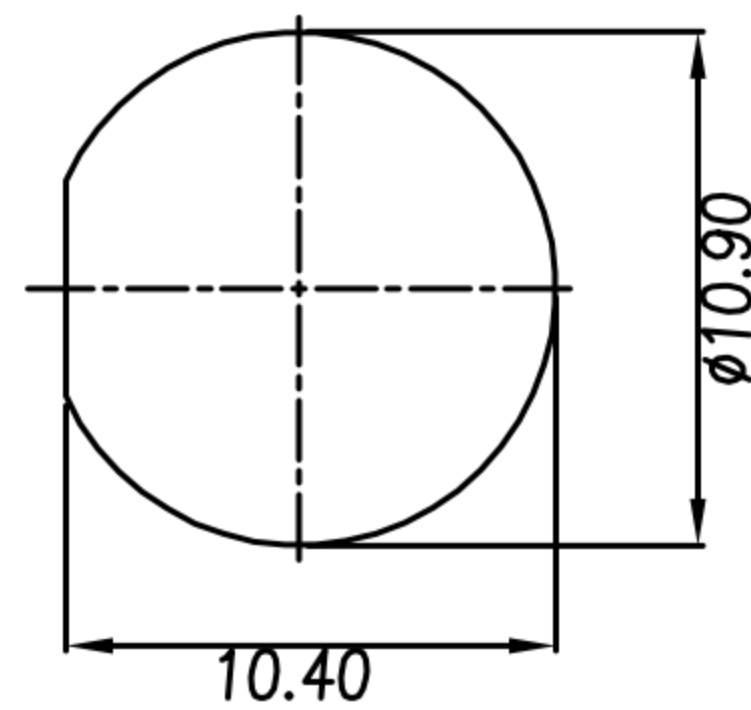
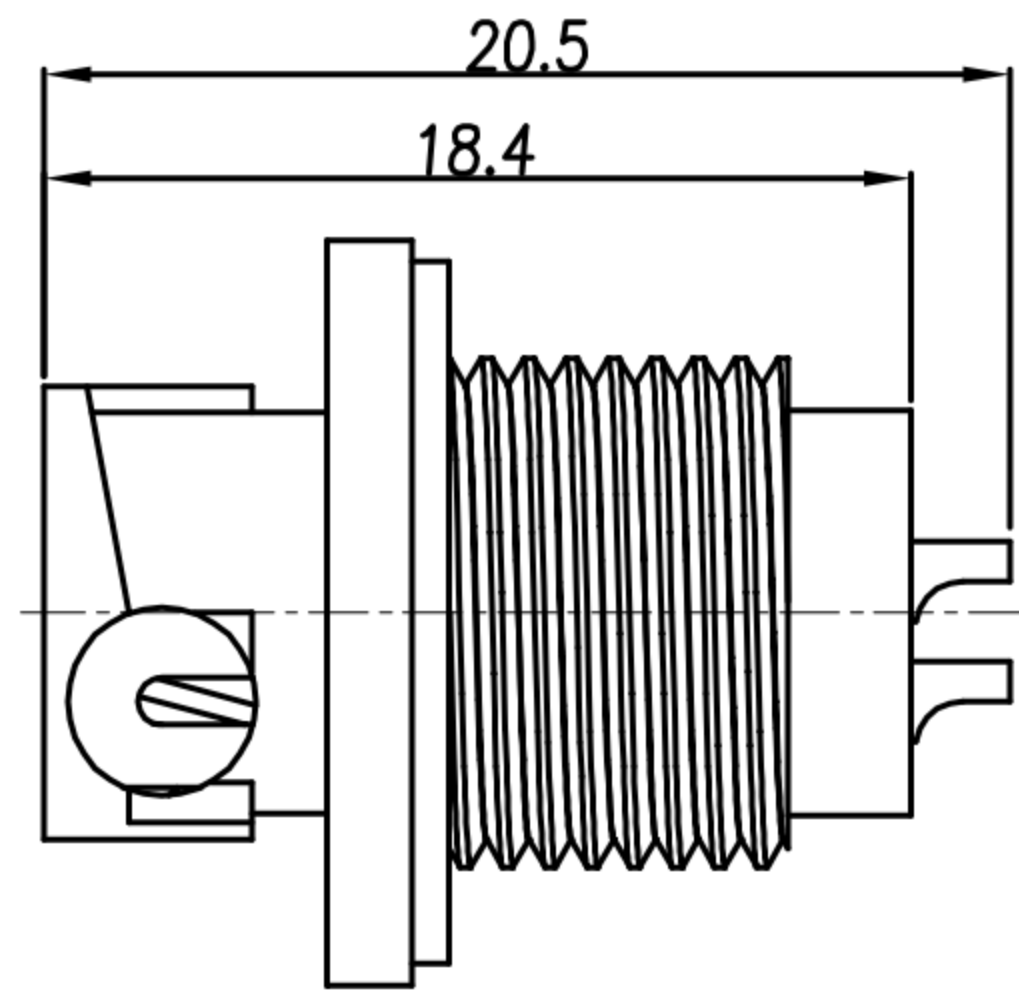
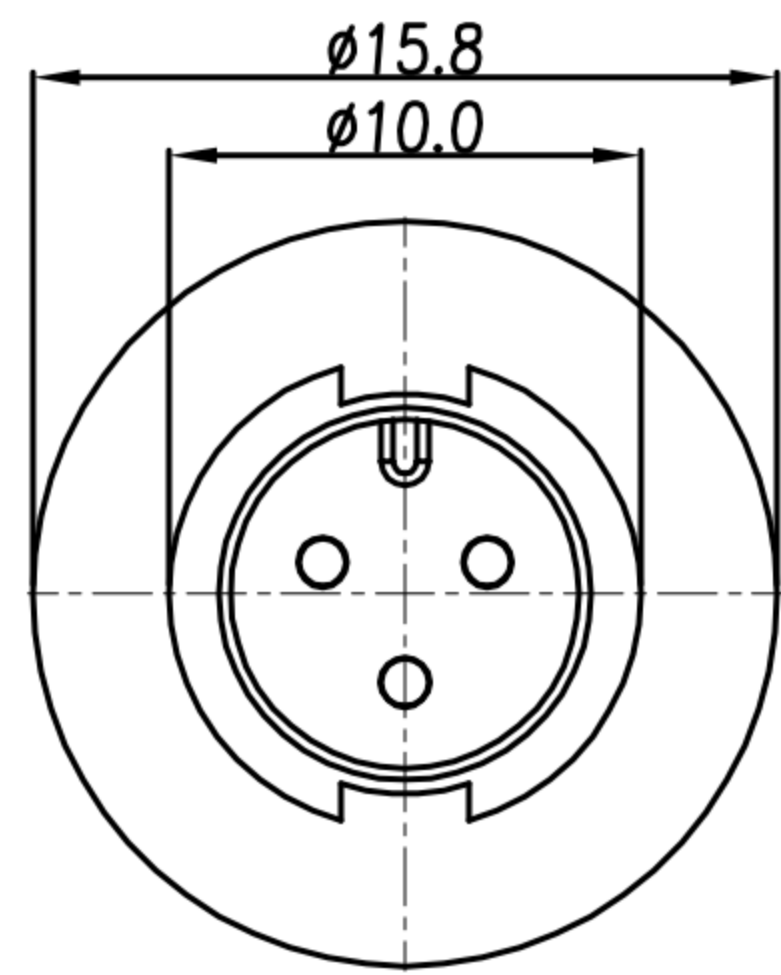

TABLE A

2 PIN	3 PIN
WP-02M2-75-11	WP-03M2-126-11

PIN ASSIGMENTS  
FRONT VIEW



RECOMMENDED PANEL CUT-OUT

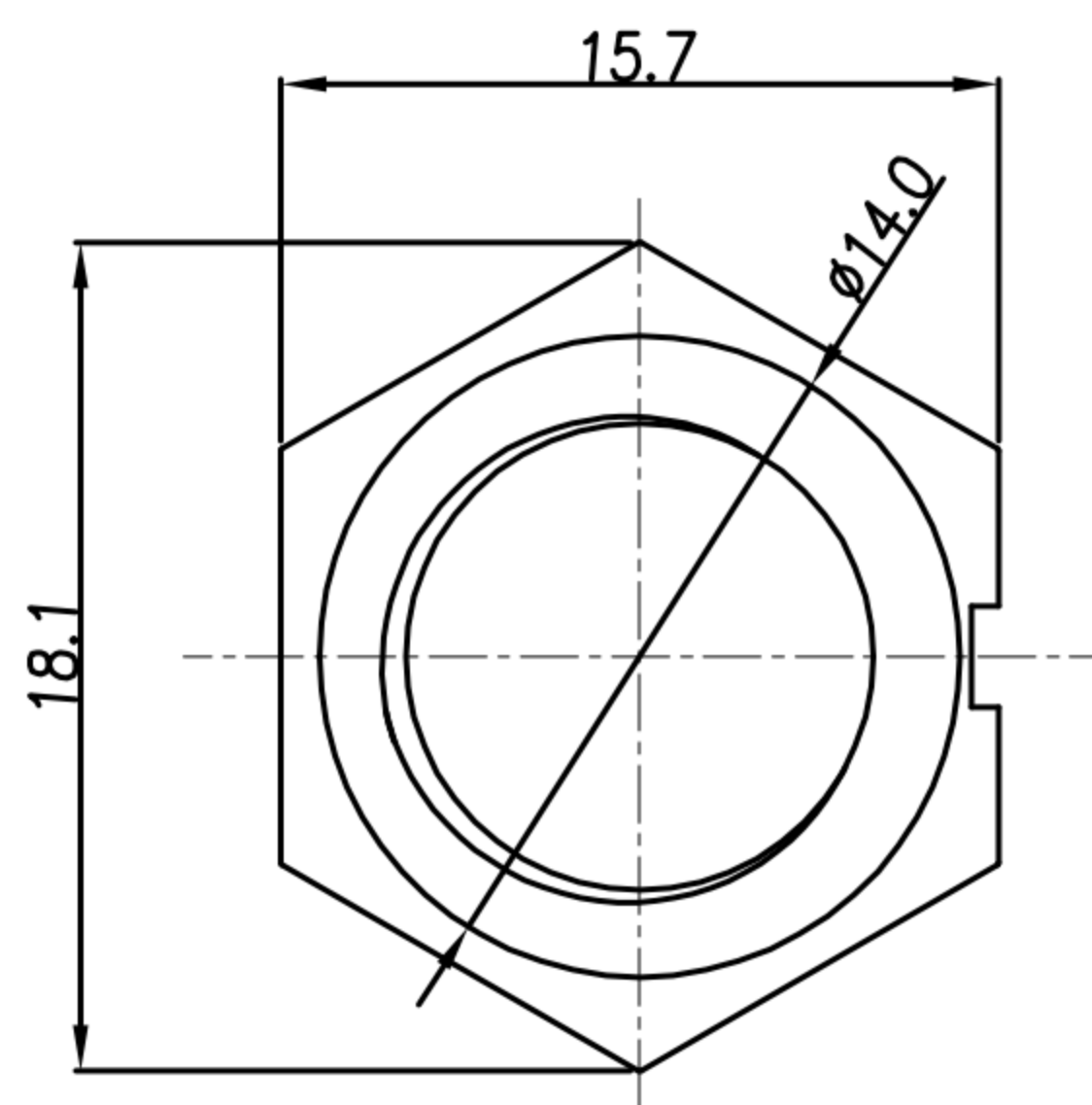

HEX NUT

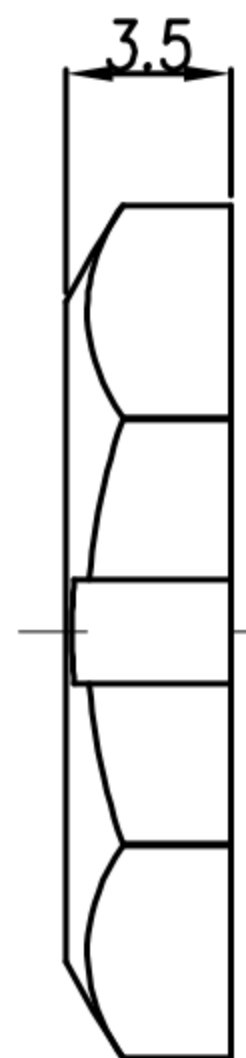

- MATERIAL :
  - HOUSING : PA66
  - CONTACT : BRASS
  - GASKET : SILICONE
  - HEX NUT : PA66
- FINISH :
  - CONTACT : GOLD FLASH PLATED.
- ELECTRICAL SPECIFICATION :
  - Rated current : 5A
  - Rated voltage : 250V
  - Water proof : IP67
- Environmental :
  - Operation Temperature : -40°C~105°C

DRAWN	Emily Suen	APP'D	Ku Chou	UNIT	mm	TOLERANCE		广东科斯达电子科技有限公司 GUANG DONG KE SI DA ELECTRONIC TECHNOLOGY CO., LTD.	TITLE	WP A SIZE M CONN M PIN REAR FASTENED (LOCK BAYONET) SOLDER TYPE			SHEET	A
CHK'D	Ku Chou	SCALE	1:1	TOLERANCE	.x ±0.20 .xx ±0.10 .xxx ±0.05 .xxxx ±0.03 ANGULA ±1°	PART NO.			SEE TABLE A	DWG NO.	QC9761	VERSION		