

# CUSTOMER DRAWING

REV.	DESCRIPTION	APPROVED BY	DATE	ECN NO.
A	RELEASE	Fido Weng	17/03/14*	
B	新增料號	KU	10/11/17*	
C	修改工作溫度	KU	26/06/18*	
D	新增料號	LED	19/07/18*	
E	新增料號	LED	15/03/19*	
F	設變彈圈結構	KU	08/05/19*	

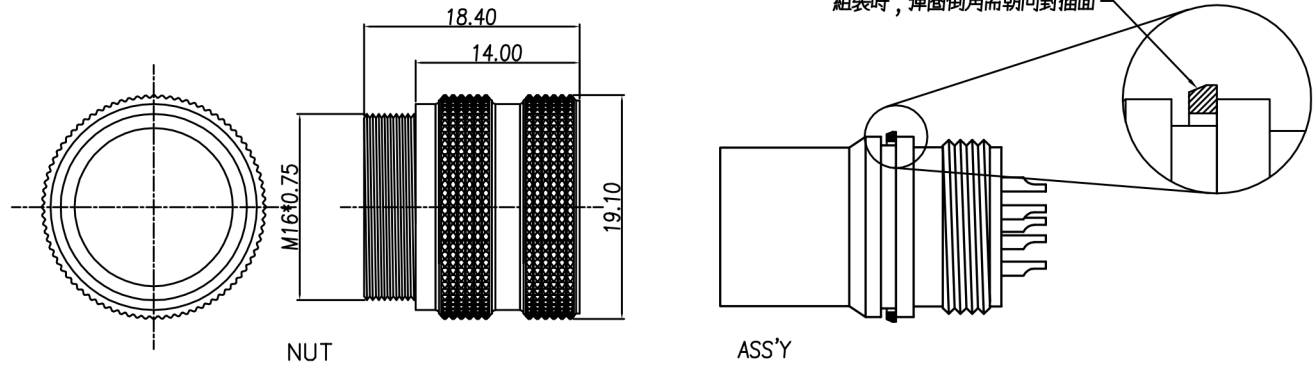
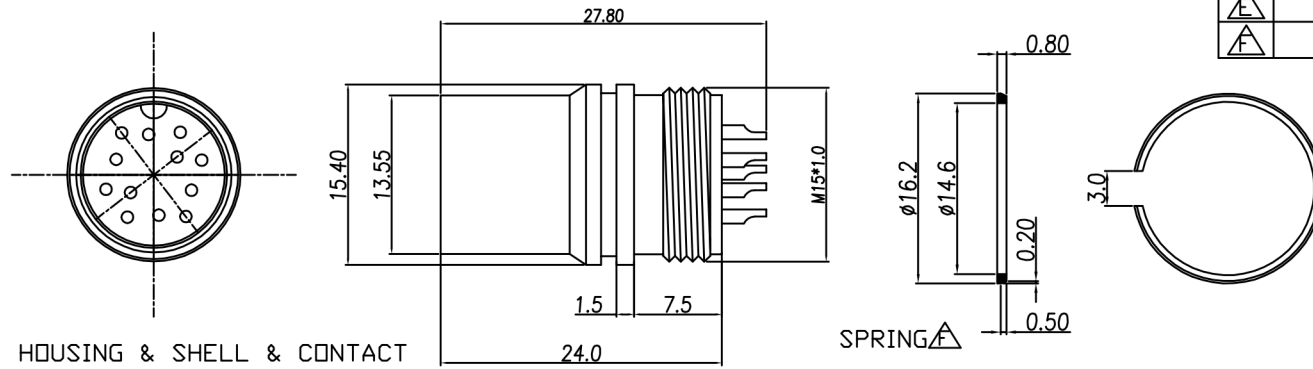

- MATERIAL :
  - 1-1. HOUSING : PA66 ; COLOR : BLACK.
  - 1-2. CONTACT : BRASS.
  - 1-3. NUT : BRASS.
  - 1-4. SHELL : ZINC ALLOY
  - 1-5. SPRING : STAINLESS STEEL.
- FINISH :
  - 2-1. CONTACT : SEE TABLE A
  - 2-2. NUT : NICKEL PLATED OVER ALL
  - 2-3. SHELL : NICKEL PLATED OVER ALL
- ELECTRICAL SPECIFICATION :
  - 3-1. Rated current : 3~8P 5A;12~14P 3A
  - 3-2. Rated voltage : 3~8P 250V;12~14P 60V
  - 3-3. Water proof : IP67
- Environmental :
  - 4-1. Operation Temperature : -40℃~85℃

TABLE A

14P	DI-14M2-01-11	GOLD FLASH PLATED
13P	DI-13M2-11-11	GOLD FLASH PLATED
12P	DI-12M2-07-11	GOLD FLASH PLATED
12P	DI-12M2-08-11	SILVER PLATED
8P	DI-08M2-13-11	GOLD FLASH PLATED
8P	DI-08M2-14-11	SILVER PLATED
7P	DI-07M2-05-11	GOLD FLASH PLATED
7P	DI-07M2-06-11	SILVER PLATED
7P	DI-07M2-13-11	GOLD FLASH PLATED
7P	DI-07M2-14-11	SILVER PLATED
6P	DI-06M2-08-11	GOLD FLASH PLATED
6P	DI-06M2-09-11	SILVER PLATED
5P	DI-05M2-08-11	GOLD FLASH PLATED
5P	DI-05M2-09-11	SILVER PLATED
4P	DI-04M2-15-11	GOLD FLASH PLATED
4P	DI-04M2-16-11	SILVER PLATED
3P	DI-03M2-04-11	GOLD FLASH PLATED
3P	DI-03M2-05-11	SILVER PLATED
PIN	P/N	CONTACT FINISH

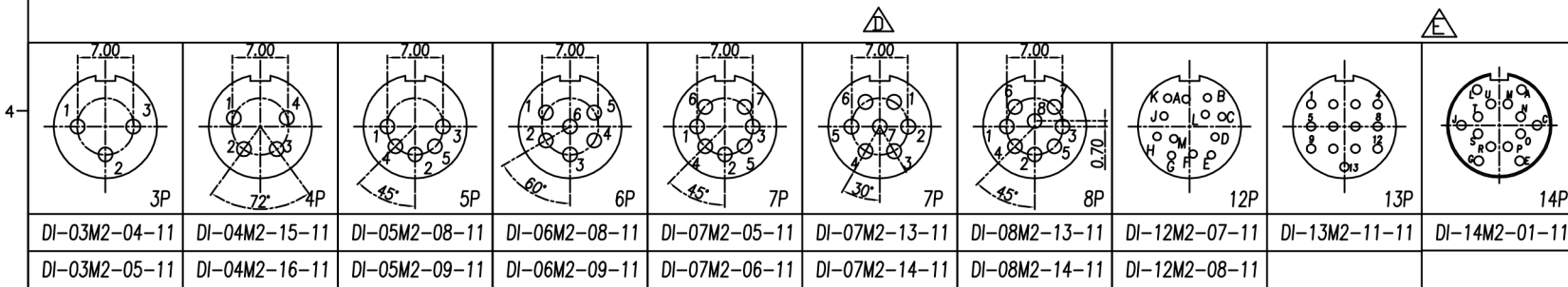

DRAWN	Ku Chou	APPEND	Emily Suen	UNIT	mm	TOLERANCE			广东科斯达电子科技有限公司 GUANG DONG KE SI DA ELECTRONIC TECHNOLOGY CO., LTD.	TITLE	防水 DIN (M) 線端成型式			SHEET	1
CHK'D	Emily Suen			SCALE	1:1	.x ±0.20 .xx ±0.10 .xxx ±0.05 .xxxx ±0.03 ANGULA ±1°				PART NO.	SEE TABLE A	DWG NO.	QC7017	VERSION	F