

CUSTOMER DRAWING

REV.	DESCRIPTION	APPROVED BY	DATE	ECN NO.
△A	RELEASE	Emily Suen	23/08/12'	
△B	修改RATED CURRENT	Ku	26/06/18'	
△C	新物料	LED	19/07/18'	
△D	新物料	LED	22/11/19'	

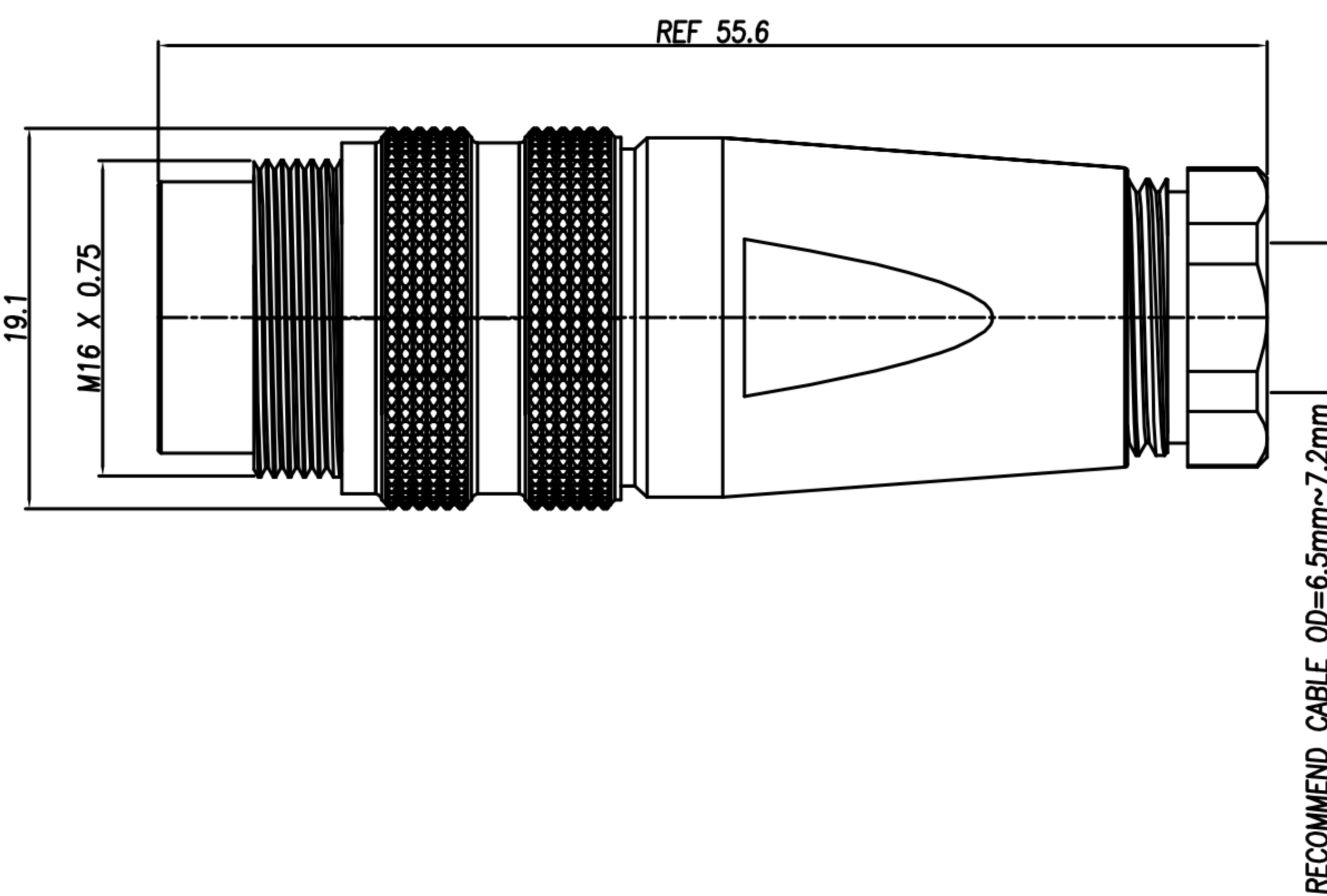
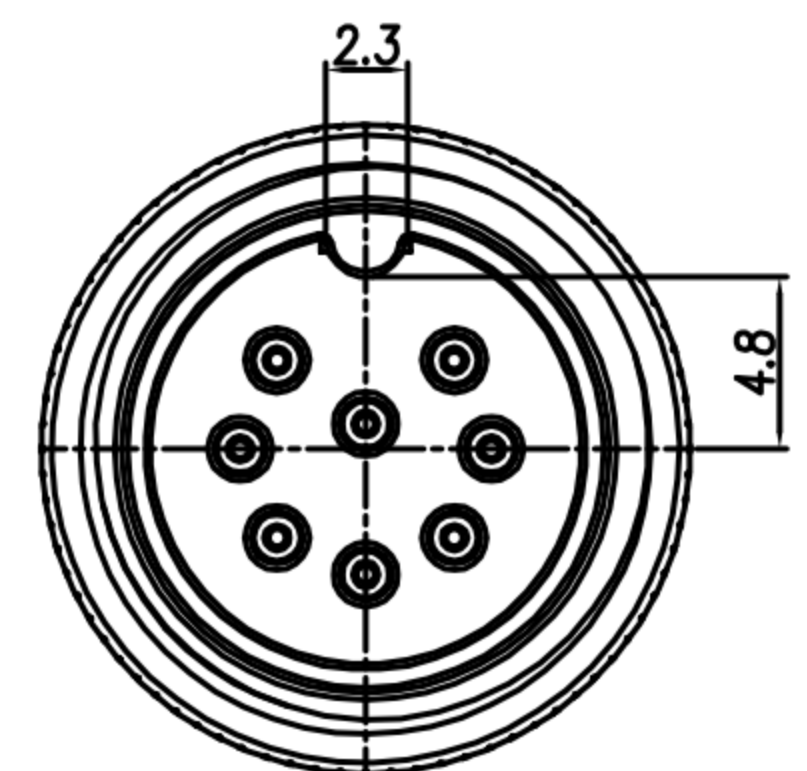

1. MATERIAL :
- 1-1. HOUSING : NYLON UL94V-0 ; COLOR : BLACK
 - 1-2. CONTACT : BRASS
 - 1-3. MAIN BODY : ZINC ALLOY
 - 1-4. LOCK SHELL : BRASS
 - 1-5. SPRING : STAINLESS
 - 1-6. ISOLATION : PVC
 - 1-7. CLAMPS : ZINC ALLOY
 - 1-8. CLAMPS BODY : ZINC ALLOY
 - 1-9. SCREW : SPCC
 - 1-10. BACK BODY : BRASS
 - 1-11. O-RING : SILICONE ; COLOR : RED
 - 1-12. GLAND : SILICONE COLOR : BLACK
 - 1-13. GLAND CAGE : POM ; COLOR : WHITE
 - 1-14. GLAND NUT : ALUMINUM ALLOY
2. FINISH :
- 2-1. CONTACT : GOLD FLASH
 - 2-2. MAIN BODY : NICKEL PLATED
 - 2-3. LOCK SHELL : NICKEL PLATED
 - 2-4. CLAMPS : NICKEL PLATED
 - 2-5. CLAMPS BODY : NICKEL PLATED
 - 2-6. SCREW : NICKEL PLATED
 - 2-7. BACK BODY : NICKEL PLATED
 - 2-8. GLAND NUT : SATING NICKEL PLATED
3. ELECTRICAL SPECIFICATION :
- △3-1. Rated current : 3PIN~8PIN 5A ; 12PIN 3A
 - 3-2. Rated Voltage : 3PIN~8PIN 250V ;12PIN 60V
 - 3-3. Water proof : IP67
4. Environmental :
- 4-1. Operation Temperature : -20 ℃~85℃

Diagram	Diagram	Diagram	Diagram	Diagram	Diagram	Diagram	Diagram	Diagram
DI-03M2-01	DI-04M2-08	DI-05M2-06	DI-05M2-23-11	DI-06M2-07	DI-07M2-04	DI-07M2-15-11	DI-08M2-08	DI-12M2-17-11

DRAWN	Mark Kao	APP'D	Ku Chou	UNIT	mm	TOLERANCE		广东科斯达电子科技有限公司 GUANG DONG KE SI DA ELECTRONIC TECHNOLOGY CO., LTD.	TITLE	WP DIN (M) Assembly type			SHEET
CHK'D	Emily Suen			SCALE	1:1	.x ±0.20 .xx ±0.10 .xxx ±0.05 .xxxx ±0.03 ANGULA ±1°			PART NO.	SEE TABLE A	DWG NO.	QC5926	VERSION

CUSTOMER DRAWING

REV.	DESCRIPTION	APPROVED BY	DATE	ECN NO.
△A	RELEASE	Emily Suen	23/08/12'	
△B				
△C				

ASSEMBLY INSTRUCTION

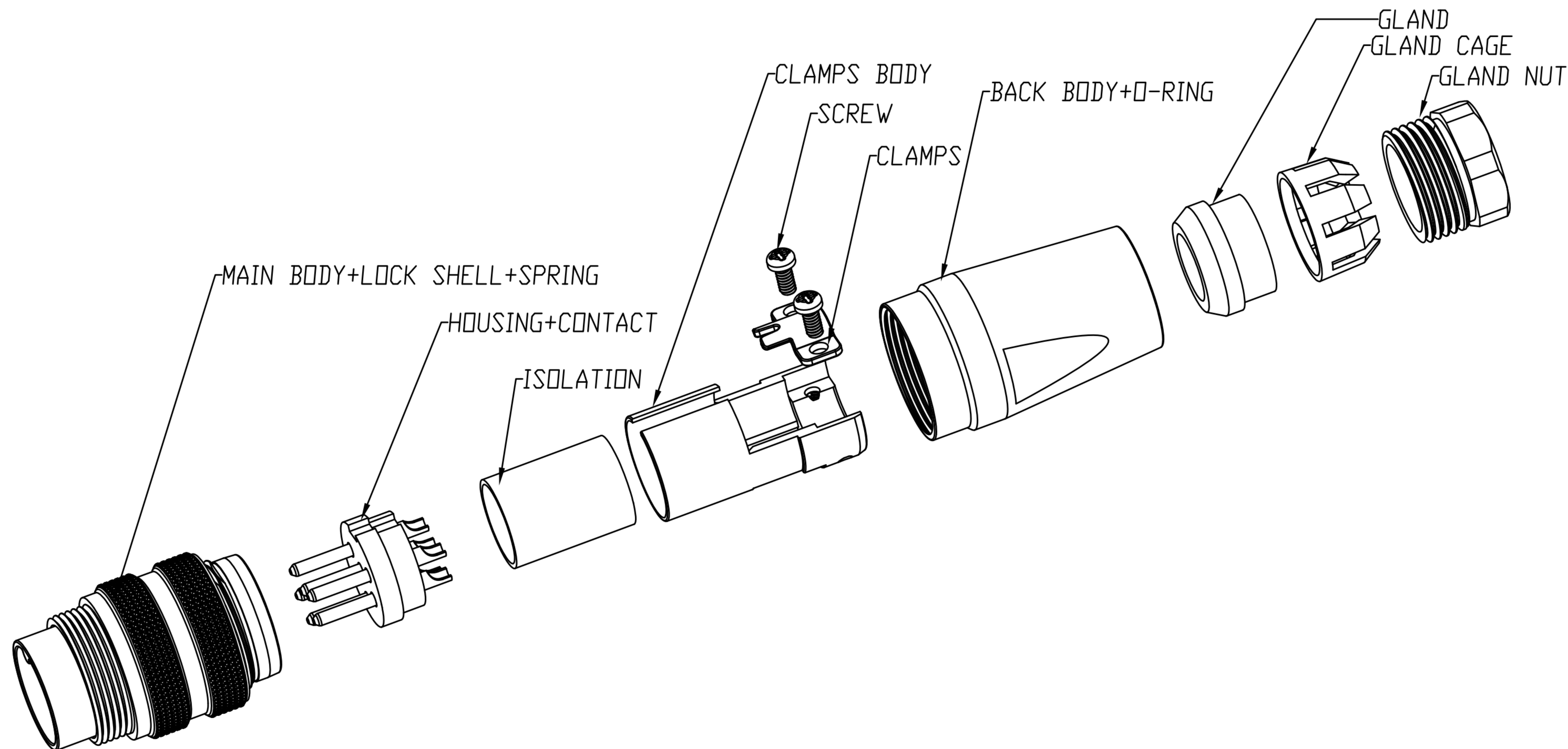

DRAWN	Mark Kao	APP'D	Ku Chou	UNIT	mm	TOLERANCE			TITLE	WP DIN (M) Assembly type			SHEET
CHK'D	Emily Suen			SCALE	1:1	.x ±0.20 .xx ±0.10 .xxx ±0.05 .xxxx ±0.03 ANGULA ±1°			PART NO.	SEE TABLE A	DWG NO.	QC5926	2 3 VERSION A

CUSTOMER DRAWING

REV.	DESCRIPTION	APPROVED BY	DATE	ECN NO.
A	RELEASE	Emily Suen	23/08/12'	
B				
C				

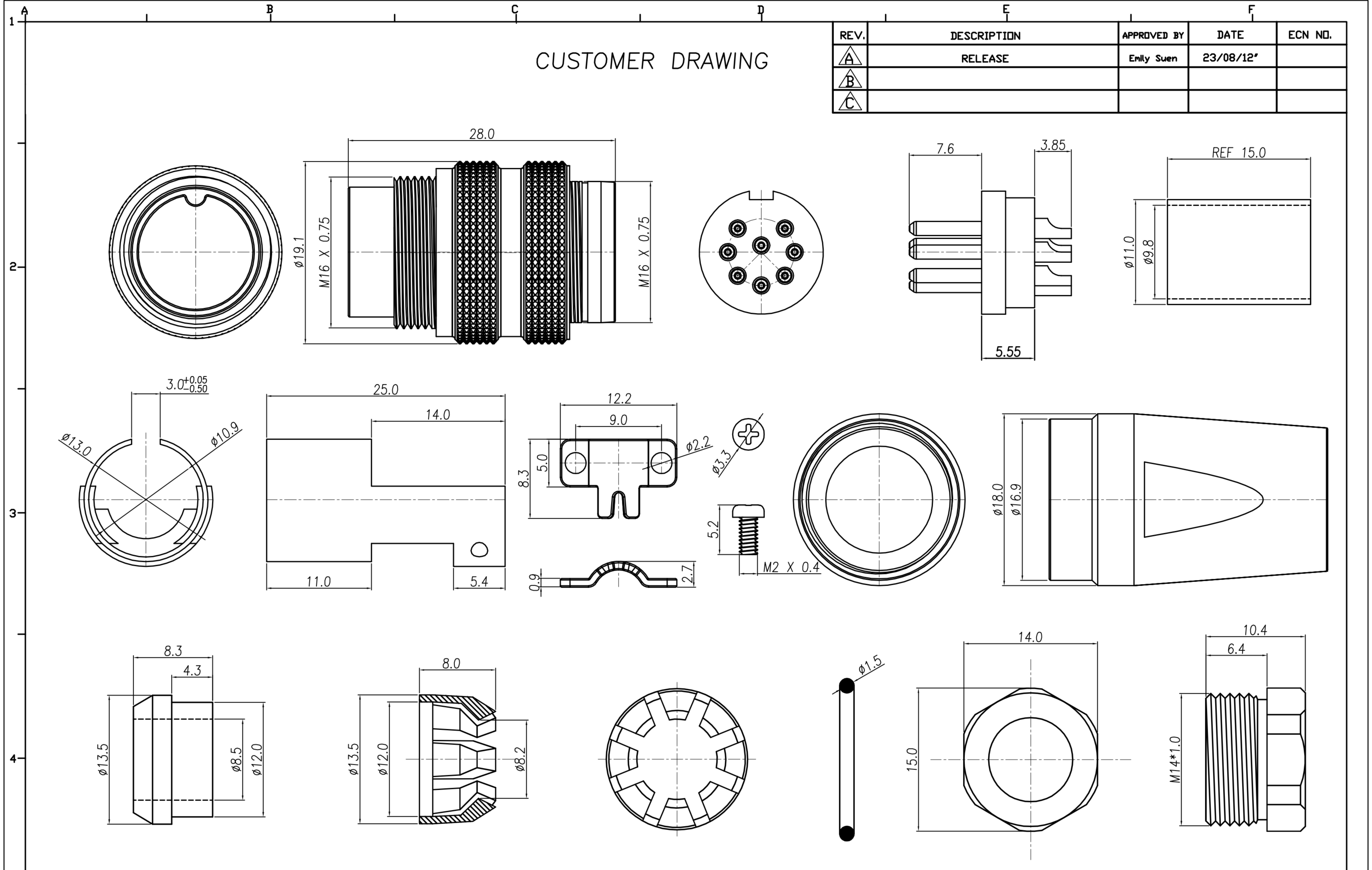

DRAWN	Mark Kao	APP'D	Ku Chou	UNIT	mm	TOLERANCE		广东科斯达电子科技有限公司 GUANG DONG KE SI DA ELECTRONIC TECHNOLOGY CO., LTD.	TITLE	WP DIN (M) Assembly type			SHEET	3
CHK'D	Emily Suen			SCALE	1:1	.x ±0.20 .xx ±0.10 .xxx ±0.05 .xxxx ±0.03 ANGULA ±1°			PART NO.	SEE TABLE A	DWG NO.	QC5926	VERSION	A