

CUSTOMER DRAWING

REV.	DESCRIPTION	APPROVED BY	DATE	ECN NO.
△A	RELEASE	Emily Suen	25/10/11'	
△B				
△C				
△D				

ASSEMBLY INSTUCTION

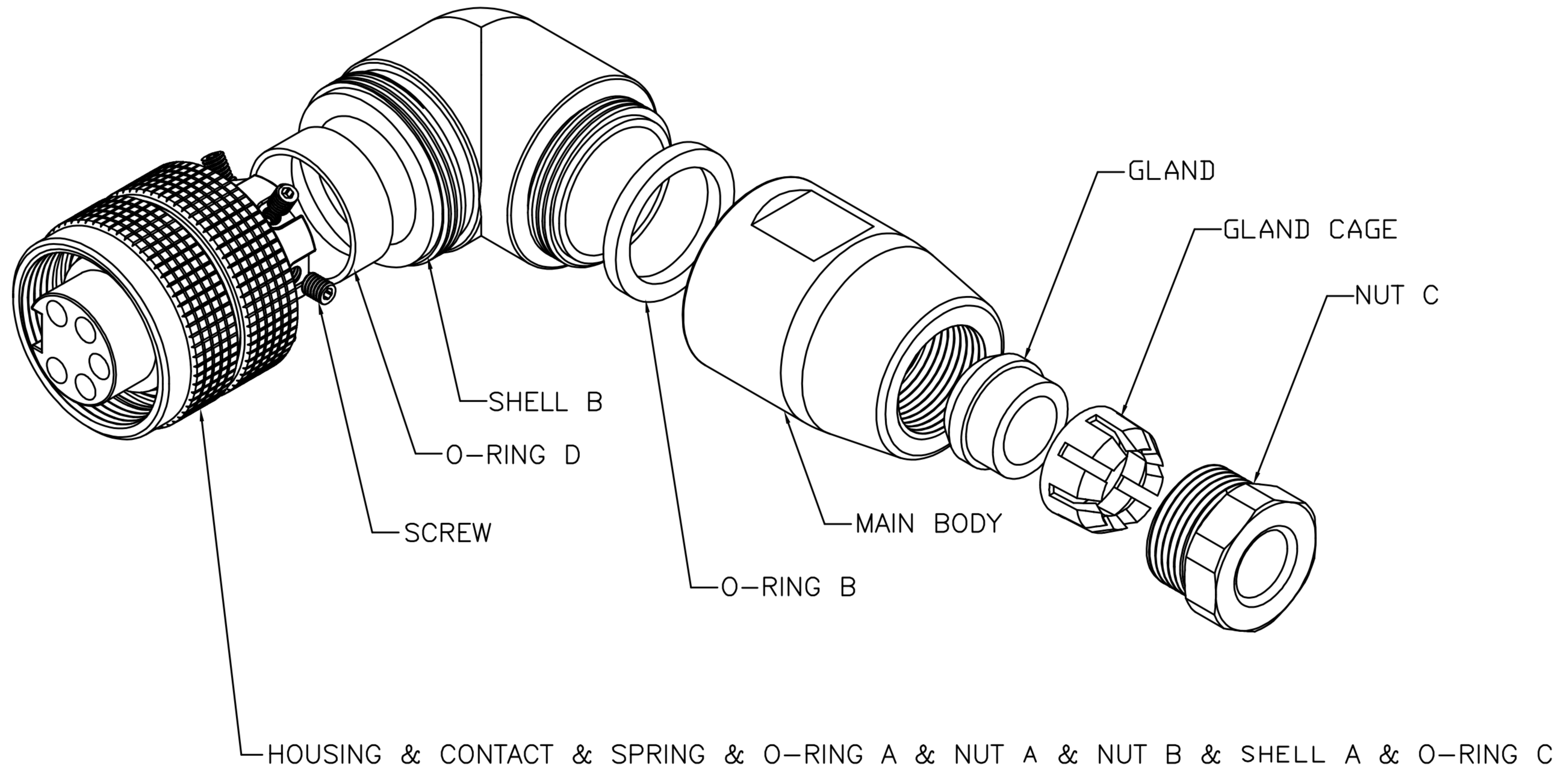

DRAWN	Emily Suen	APPVL	Ku Chou	UNIT	mm	TOLERANCE		广东科斯达电子科技有限公司 GUANG DONG KE SI DA ELECTRONIC TECHNOLOGY CO., LTD.	TITLE	7/8" 5PIN (F) 90° Assembly type			SHEET	2
CHK'D	Emily Suen			SCALE	1:1	.x ±0.20 .xx ±0.10 .xxx ±0.05 .xxxx ±0.03 ANGULA ±1°			PART NO.	WP-05F2-116-11	DWG NO.	QC7448	VERSION	A

CUSTOMER DRAWING

REV.	DESCRIPTION	APPROVED BY	DATE	ECN NO.
△A				
△B				
△C				

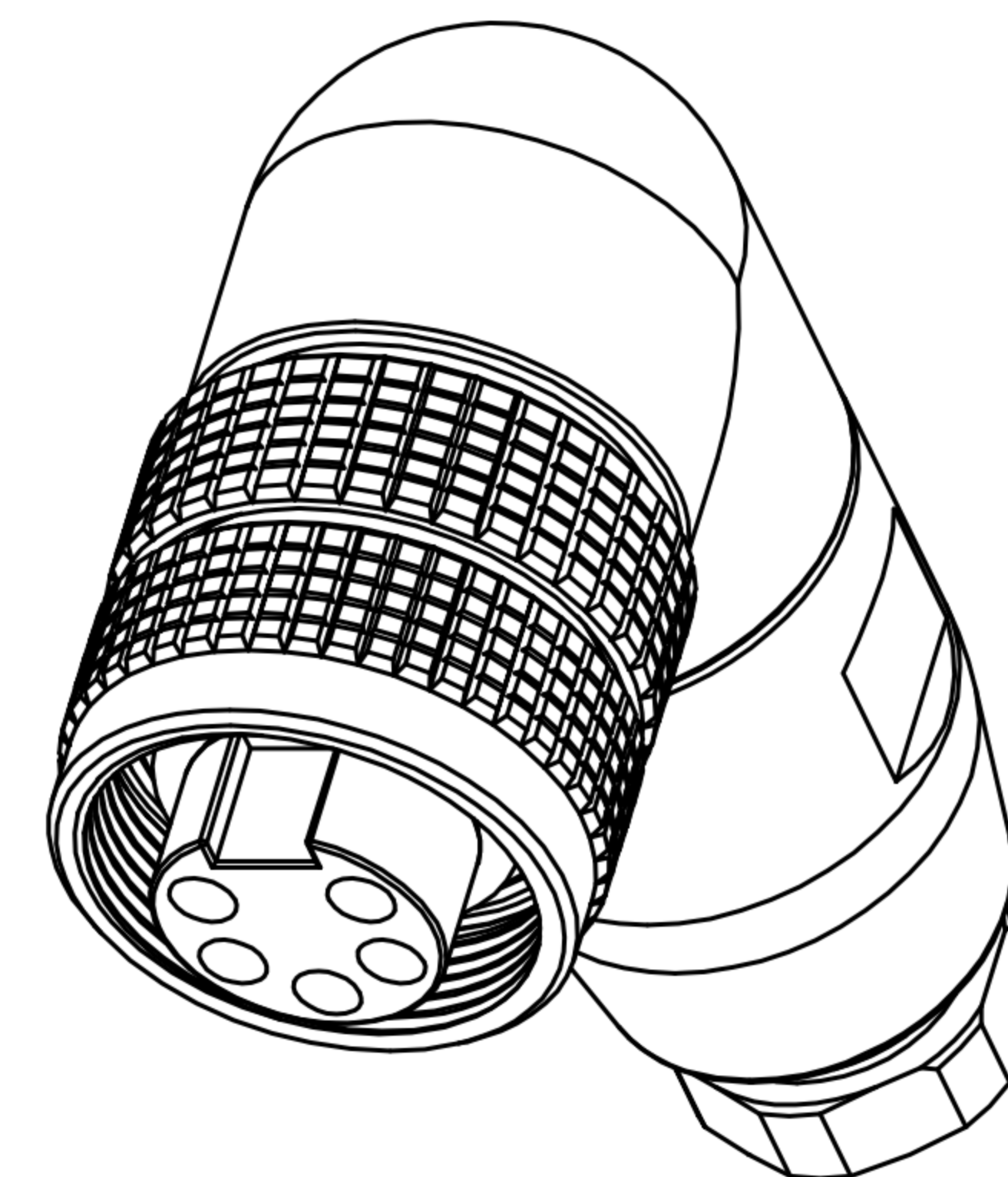
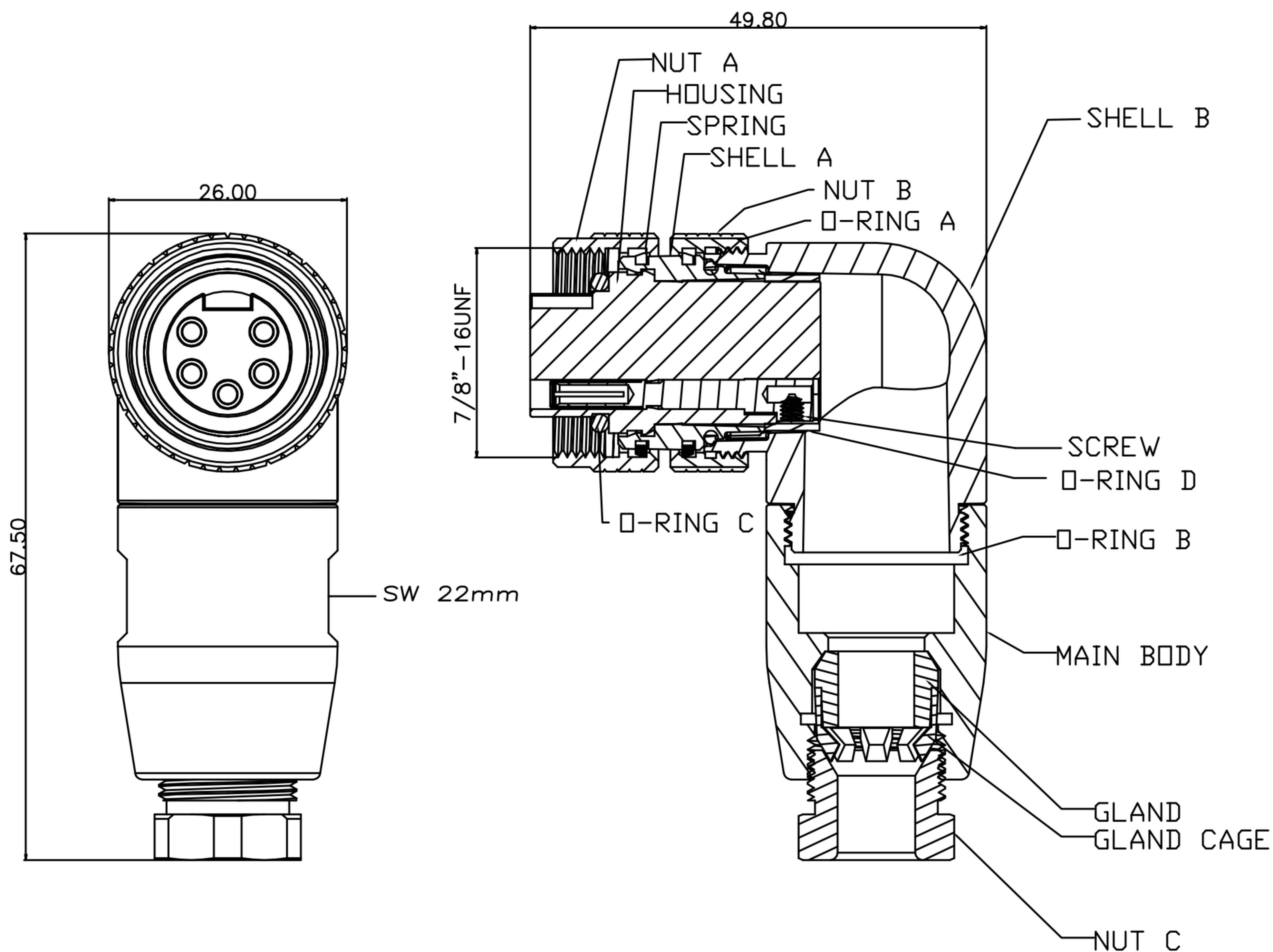

1. MATERIAL :
 - 1-1. HOUSING : TPU ; COLOR : YELLOW.
 - 1-2. SPRING : STAINLESS STEEL.
 - 1-3. O-RING A : NBR ; COLOR : BLACK.
 - 1-4. NUT A : BRASS.
 - 1-5. NUT B : BRASS.
 - 1-6. SHELL A : ALUMINIUM ALLOY
 - 1-7. SHELL B : ALUMINIUM ALLOY
 - 1-8. CONTACT : BRASS.
 - 1-9. SCREW : ALLOY STEEL
 - 1-10. MAIN BODY : ALUMINIUM ALLOY
 - 1-11. GLAND : SILICONE COLOR : BLACK.
 - 1-12. GLAND CAGE : POM ; COLOR : WHITE.
 - 1-13. NUT C : ALUMINIUM ALLOY
 - 1-14. O-RING B : SILICONE ; COLOR : BLACK.
 - 1-15. O-RING C : EPDM ; COLOR : BLACK.
 - 1-16. O-RING D : SILICONE ; COLOR : BLACK
2. FINISH :
 - 2-1. NUT A : NICKEL PLATED OVER ALL
 - 2-2. NUT B : NICKEL PLATED OVER ALL
 - 2-3. SHELL A: NICKEL PLATED OVER ALL
 - 2-4. SHELL B: NICKEL PLATED OVER ALL
 - 2-5. CONTACT : GOLD FLASH MIN. GOLD PLATED.
 - 2-6. SCREW: NICKEL PLATED OVER ALL
 - 2-7. MAIN BODY : NICKEL PLATED OVER ALL
 - 2-8. NUT C : NICKEL PLATED OVER ALL
3. ELECTRICAL SPECIFICATION :
 - 3-1. Rated current : 20A
 - 3-2. Rated voltage : 250V
 - 3-3. Water proof: IP67
4. Environmental :
 - 4-1. Operation Temperature : -40℃~85℃

DRAWN	LEO	APP'D	Emily Suen	UNIT	mm	TOLERANCE		广东科斯达电子科技有限公司 GUANG DONG KE SI DA ELECTRONIC TECHNOLOGY CO., LTD.	TITLE	7/8" 5PIN (F) 90° Assembly type			SHEET	1/2
CHK'D	Emily Suen			SCALE	1:1	.x ±0.25 .xx ±0.10 .xxx ±0.05 .xxxx ±0.03 ANGULA ±1°			PART NO.	WP-05F2-116-11	DWG NO.	QC7448	VERSION	A