

CUSTOMER DRAWING

REV.	DESCRIPTION	APPROVED BY	DATE	ECN NO.
A	RELEASE	Ku Chou	20/07/18'	
B	CHANGE CLAMP RING MATERIAL	Ku Chou	31/10/18'	
C				

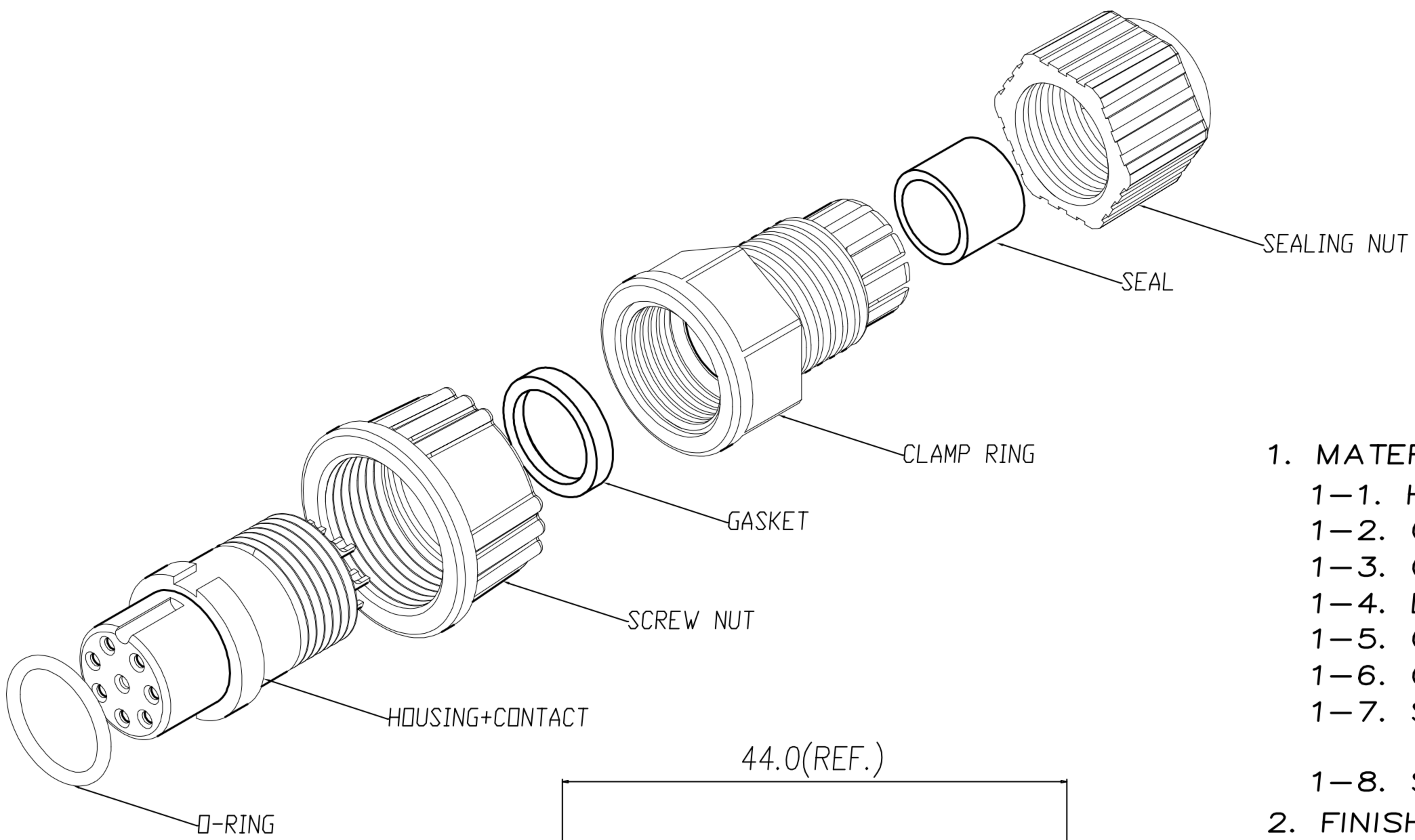
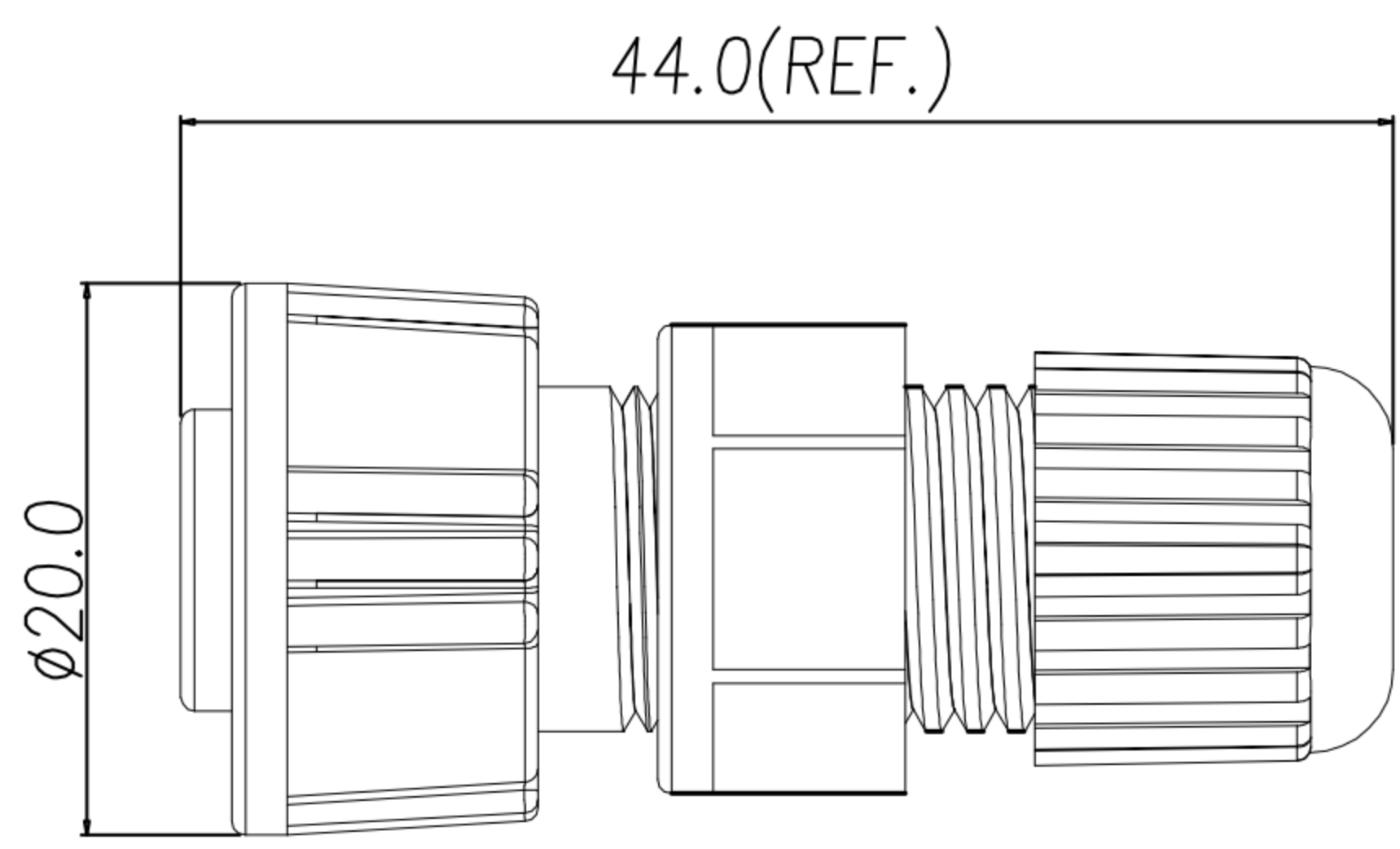

TABLE A

6 PIN WP-06F2-64-11	7 PIN WP-07F2-12-11	8 PIN WP-08F2-103-11	
2 PIN WP-02F2-57-11	3 PIN WP-03F2-99-11	4 PIN WP-04F2-197-11	5 PIN WP-05F2-152-11

PIN ASSIGNMENTS
FRONT VIEW

- MATERIAL :
 - 1-1. HOUSING : PA66
 - 1-2. CONTACT : BRASS
 - 1-3. O-RING : SILICONE
 - 1-4. LOCK NUT : PA66
 - 1-5. GASKET : SILICONE
 - 1-6. CLAMP RING : PA66 $\triangle B$
 - 1-7. SEAL : SILICONE
 - 1-8. SEALING NUT : PA66
- FINISH :
 - 2-1. CONTACT : GOLD FLASH PLATED.
- ELECTRICAL SPECIFICATION :
 - 3-1. Rated current : 5A
 - 3-2. Rated voltage : 250V
 - 3-3. Water proof : IP67
- Environmental :
 - 4-1. Operation Temperature : $-40^{\circ}\text{C} \sim 105^{\circ}\text{C}$



DRAWN	Emily Suen	APP'D	Ku Chou	UNIT	mm	TOLERANCE		广东科斯达电子科技有限公司 GUANG DONG KE SI DA ELECTRONIC TECHNOLOGY CO., LTD.	TITLE	WP (F) (SCREW) B SIZE ASSEMBLY TYPE(5A)			SHEET	1
CHK'D	Ku Chou			SCALE	1:1	.x ± 0.20 .xx ± 0.10 .xxx ± 0.05 .xxxx ± 0.03 ANGULA $\pm 1^{\circ}$			PART NO.	SEE TABLE A	DWG NO.	QC8638	VERSION	