

CUSTOMER DRAWING

REV.	DESCRIPTION	APPROVED BY	DATE	ECN NO.
△A	RELEASE	Ku Chou	16/11/18*	
△B				
△C				

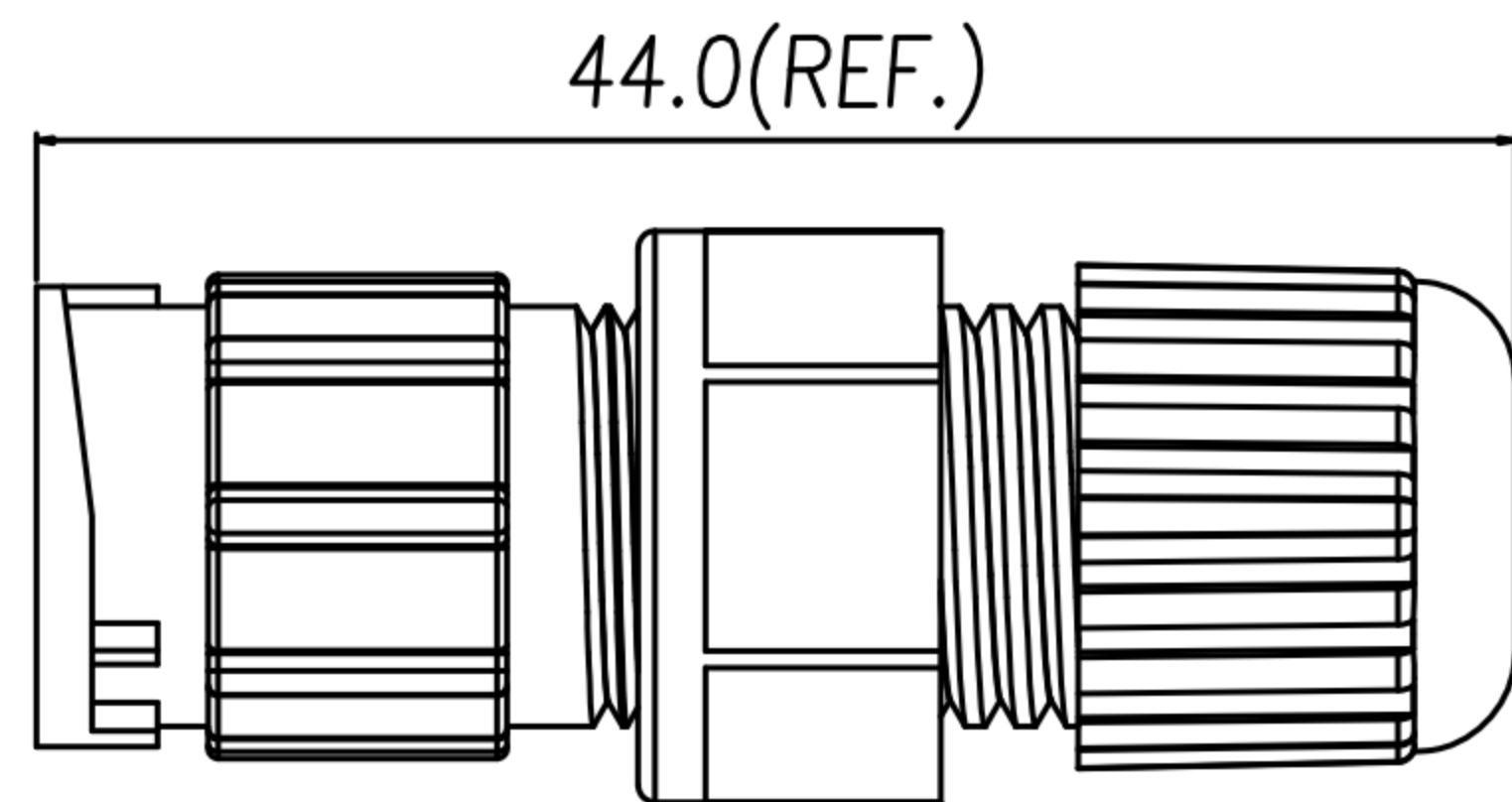
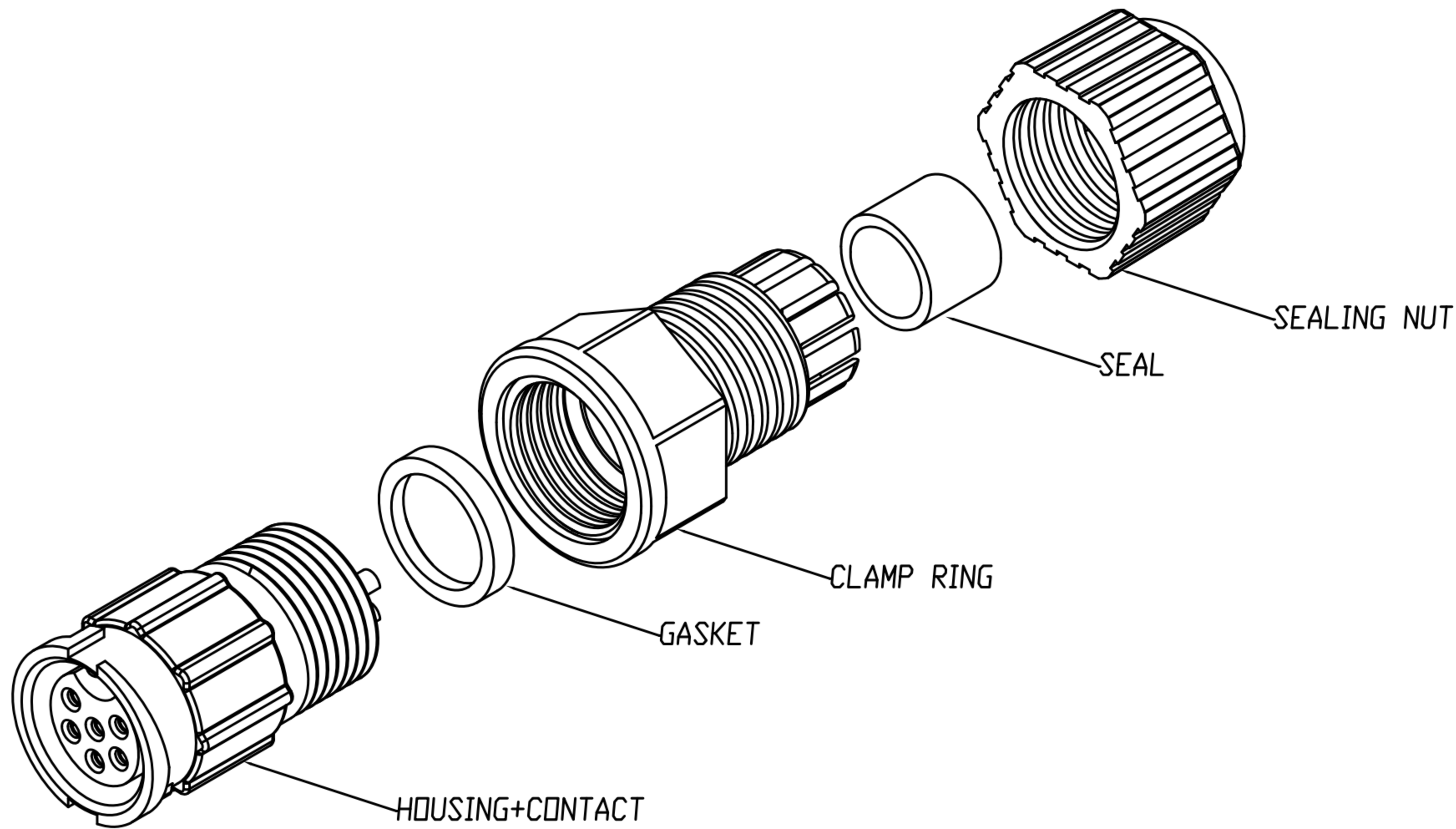

TABLE A

5 PIN WP-05F2-228-11	6 PIN WP-06F2-95-11	
2 PIN	3 PIN WP-03F2-103-11	4 PIN WP-04F2-288-11
PIN ASSIGMENTS FRONT VIEW		

1. MATERIAL :
 - 1-1. HOUSING : PA66
 - 1-2. CONTACT : BRASS
 - 1-3. GASKET : SILICONE
 - 1-4. CLAMP RING : PA66
 - 1-5. SEAL : SILICONE
 - 1-6. SEALING NUT : PA66
2. FINISH :
 - 2-1. CONTACT : GOLD FLASH PLATED.
3. ELECTRICAL SPECIFICATION :
 - 3-1. Rated current : 5A
 - 3-2. Rated voltage : 250V
 - 3-3. Water proof : IP67
4. Environmental :
 - 4-1. Operation Temperature : -40℃~105℃

DRAWN	Emily Suen	APP'D	Ku Chou	UNIT	mm	TOLERANCE		广东科斯达电子科技有限公司 GUANG DONG KE SI DA ELECTRONIC TECHNOLOGY CO., LTD.	TITLE	WP (M CONN. F PIN) (LOCK) B SIZE ASSEMBLY TYPE(5A)			SHEET	1/1
CHK'D	Ku Chou			SCALE	1:1	.x ±0.20 .xx ±0.10 .xxx ±0.05 .xxxx ±0.03 ANGULA ±1°			PART NO.	SEE TABLE A	DWG NO.	QC8809	VERSION	