

CUSTOMER DRAWING

REV.	DESCRIPTION	APPROVED BY	DATE	ECN NO.
△A	RELEASE	Fido Weng	30/05/13'	
△B	ADD PART NO.	Ku	26/04/19'	
△C				

1. MATERIAL :
 - 1-1. HOUSING : SEE TABLE A ; COLOR : BLACK
 - 1-2. CONTACT : BRASS
 - 1-3. NUT : SEE TABLE A
 - 1-4. SHELL : SEE TABLE A
 - 1-5. O-RING : EDPM ; COLOR : BLACK
2. FINISH :
 - 2-1. CONTACT : SEE TABLE A
UNDER PLATE : NICKEL
 - 2-2. NUT : SEE TABLE A
 - 2-3. SHELL : SEE TABLE A
3. ELECTRICAL SPECIFICATION :
 - 3-1. Rated current : 4A
 - 3-2. Rated voltage : 3~4PIN 250V ; 5PIN 60V
 - 3-3. Water proof : IPX7
4. Environmental :
 - 4-1. Operation Temperature : -40℃~85℃

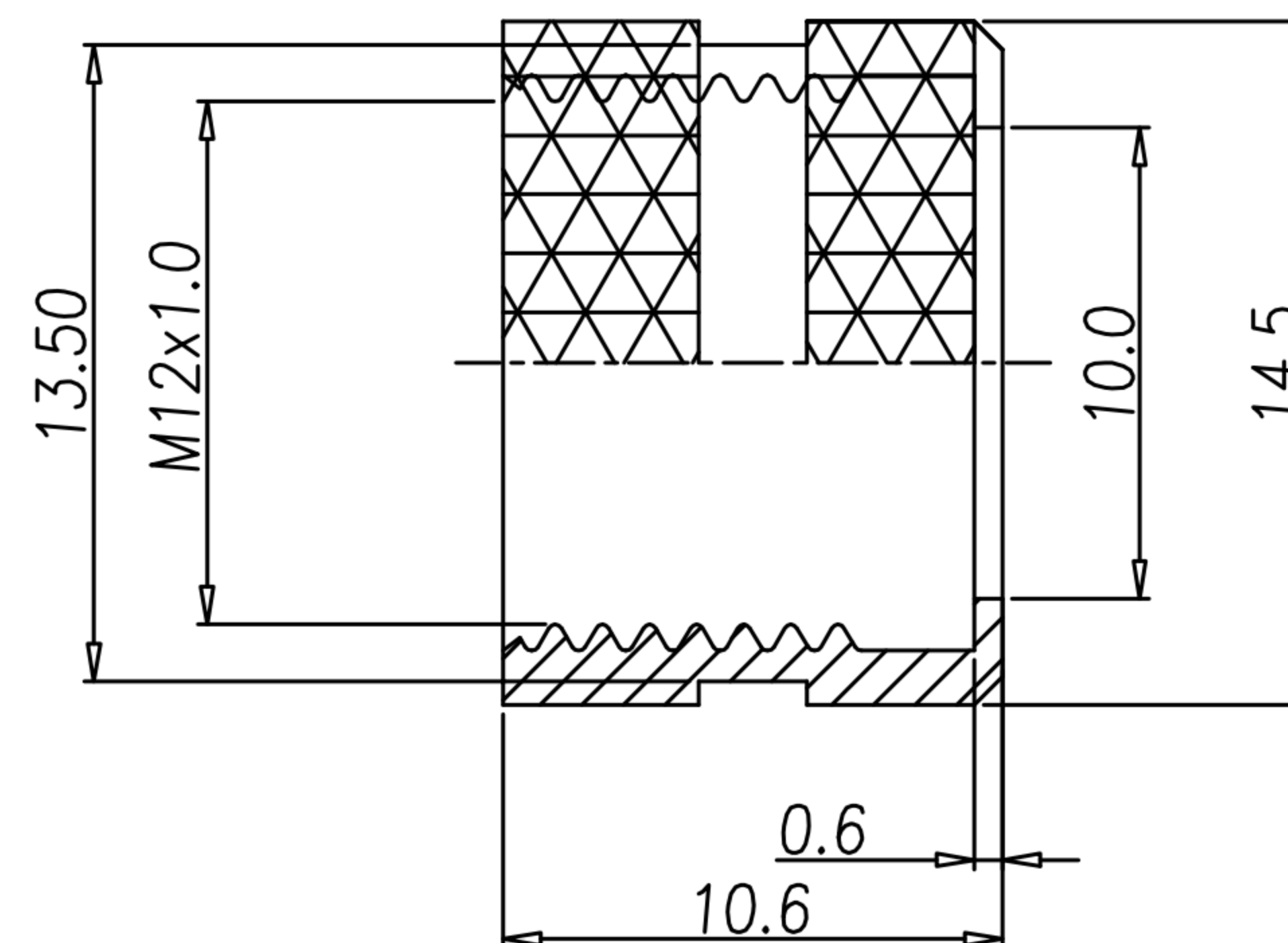
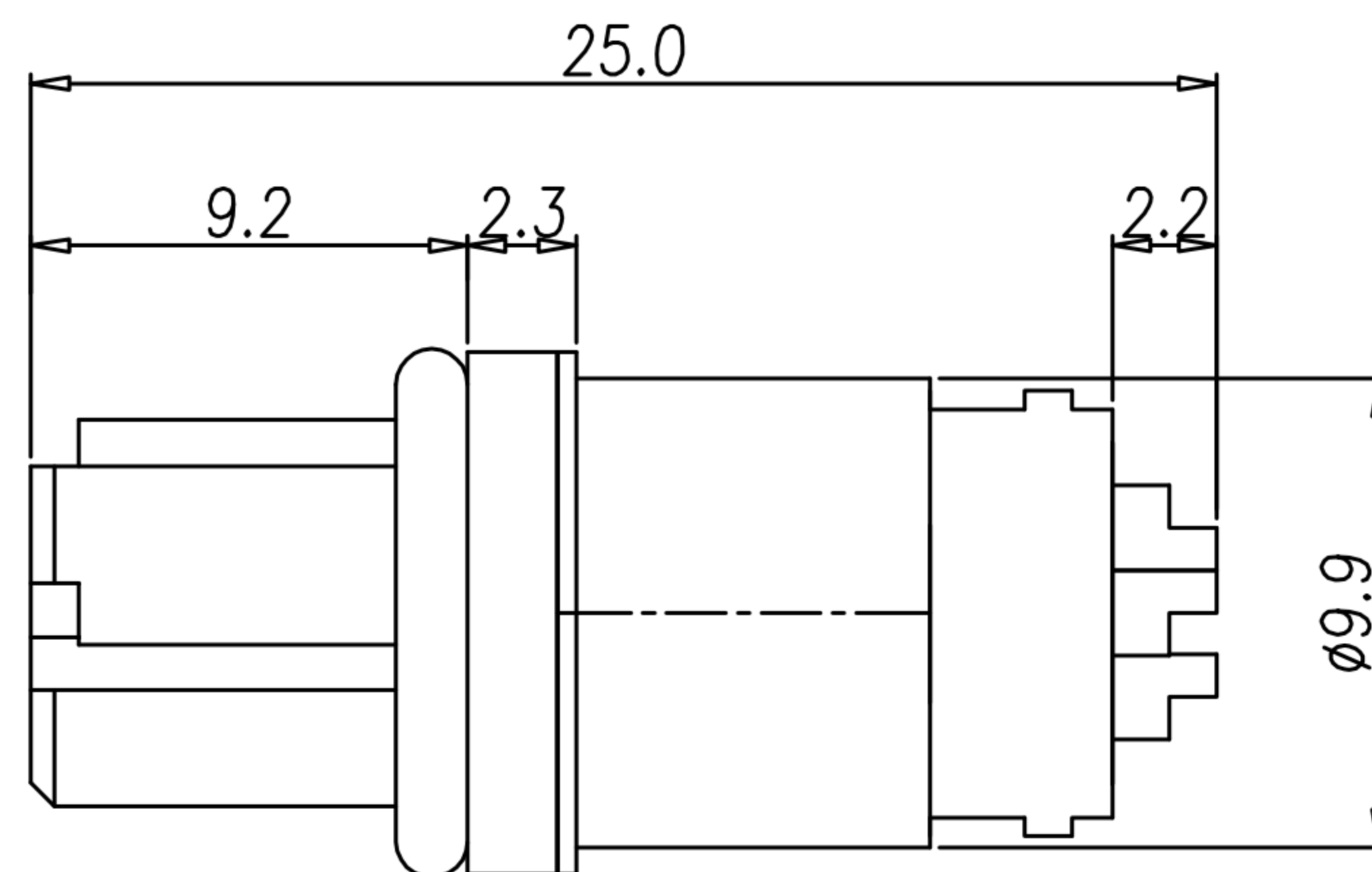
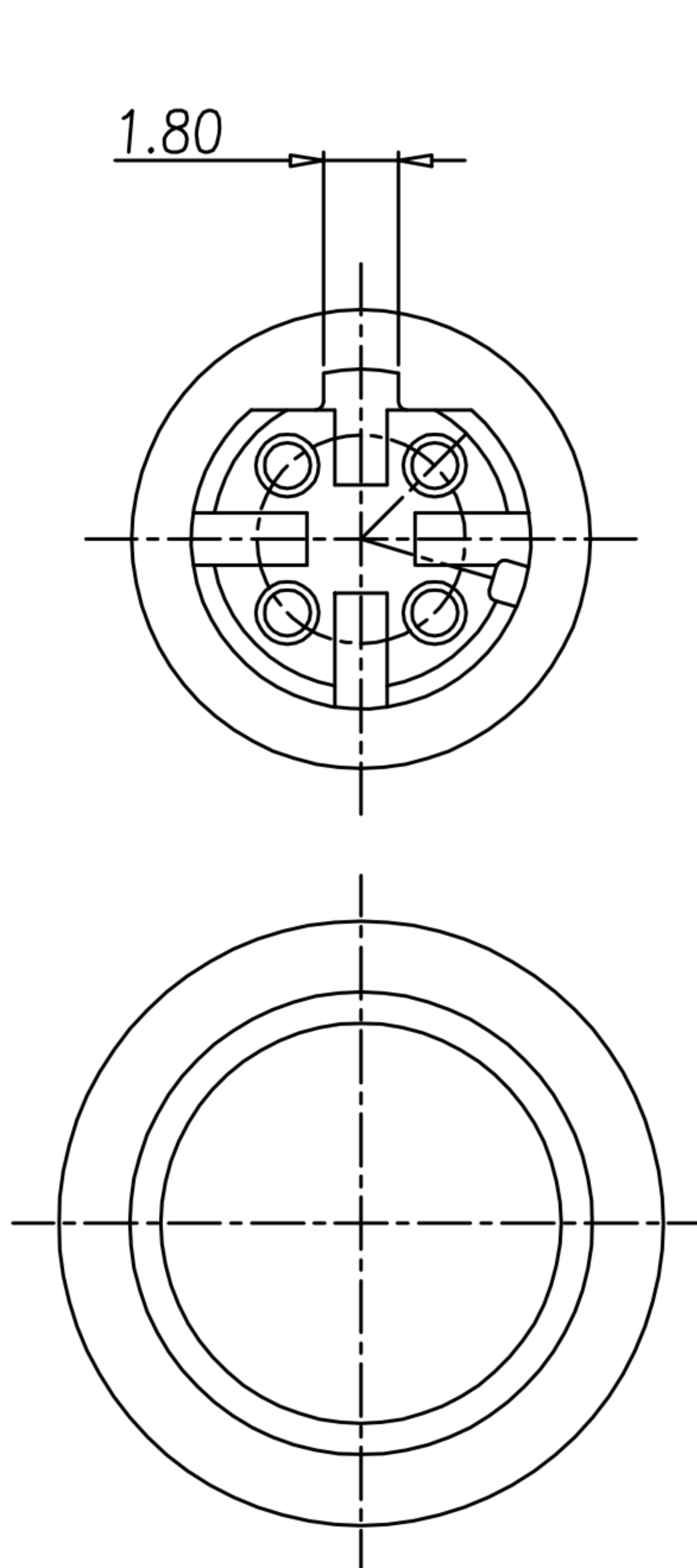

TABLE A △B

5PIN	4PIN	3PIN
WP-05F2-79-11	WP-04F2-105-11 WP-04F2-158-11 WP-04F2-221-11 WP-04F2-287-11 WP-04F2-269-11 WP-04F2-270-11	WP-03F2-37-11

WP-04F2-269-11	TPU	STAINLESS STEEL 316	-	STAINLESS STEEL 316	-	10u" GOLD PLATED
WP-04F2-270-11	TPU	BRASS	NICKEL PLATED	STAINLESS STEEL 316	-	10u" GOLD PLATED
WP-04F2-287-11	PBT	BRASS	NICKEL PLATED	BRASS	NICKEL PLATED	GOLD FLASH PLATED
WP-04F2-221-11	PBT	BRASS	NICKEL PLATED	BRASS	NICKEL PLATED	10u" GOLD PLATED
WP-05F2-79-11	TPU	BRASS	NICKEL PLATED	BRASS	NICKEL PLATED	10u" GOLD PLATED
WP-04F2-105-11	TPU	BRASS	NICKEL PLATED	BRASS	NICKEL PLATED	10u" GOLD PLATED
WP-04F2-158-11	TPU	BRASS	NICKEL PLATED	BRASS	NICKEL PLATED	GOLD FLASH PLATED
WP-03F2-37-11	TPU	BRASS	NICKEL PLATED	BRASS	NICKEL PLATED	10u" GOLD PLATED
PART No.	MATERIAL(HOUSING)	MATERIAL(SHELL)	FINISH(SHELL)	MATERIAL(NUT)	FINISH(NUT)	FINISH(CONTACT)

DRAWN	Ku Chou	APPEND	Fido Weng	UNIT	mm	TOLERANCE			TITLE	防水頭 (F) D-code線端焊線式+接地			SHEET	1/2
CHKED	Emily Suen			SCALE	1:1	.x ±0.20 .xx ±0.10 .xxx ±0.05 .xxxx ±0.03 ANGULA ±1°			PART NO.	SEE TABLE A	DWG NO.	QC6204	VERSION	B