

CUSTOMER DRAWING

REV.	DESCRIPTION	APPROVED BY	DATE	ECN NO.
△A	RELEASE	Fido Weng	01/12/17'	
△B				
△C				

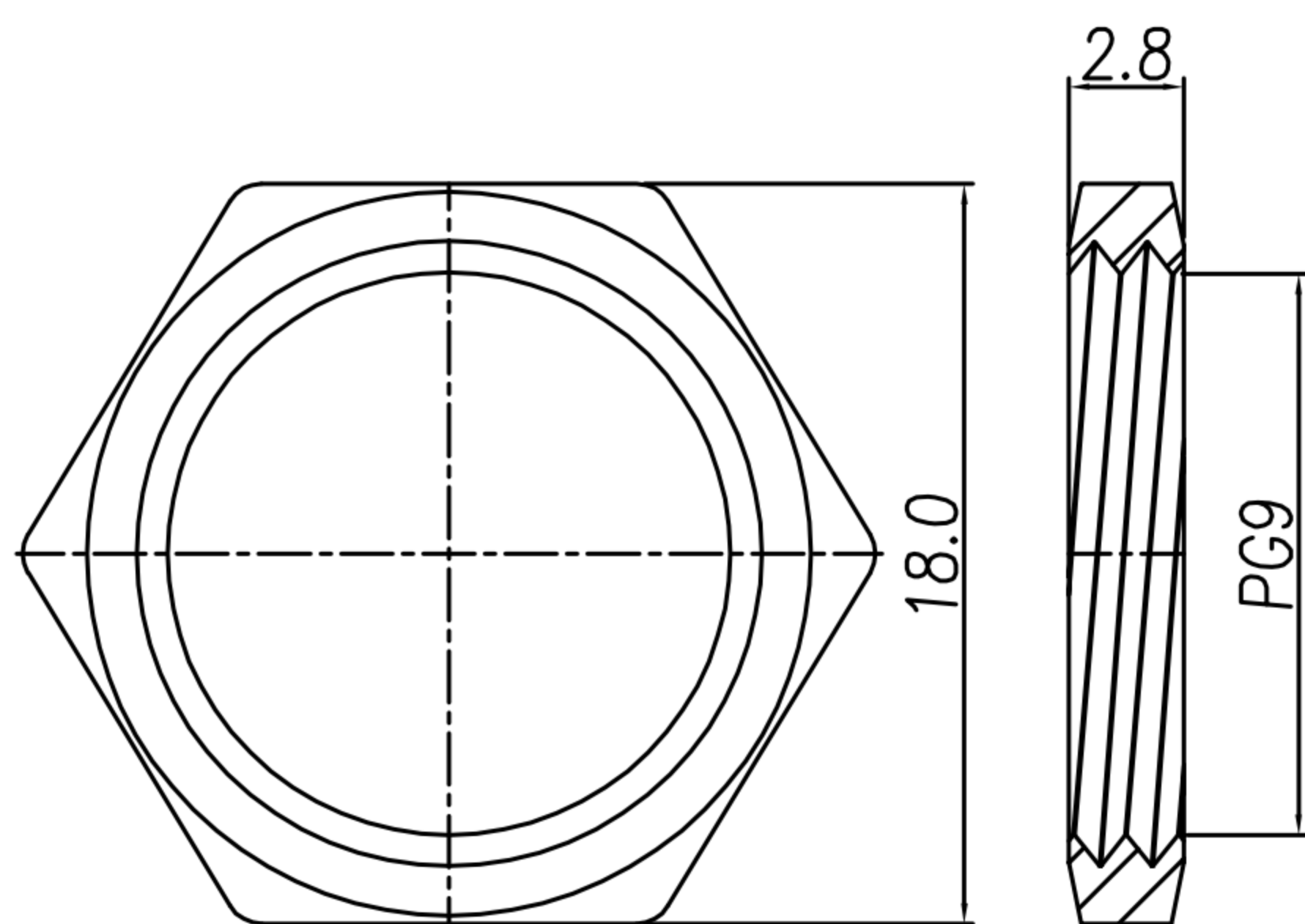

NUT

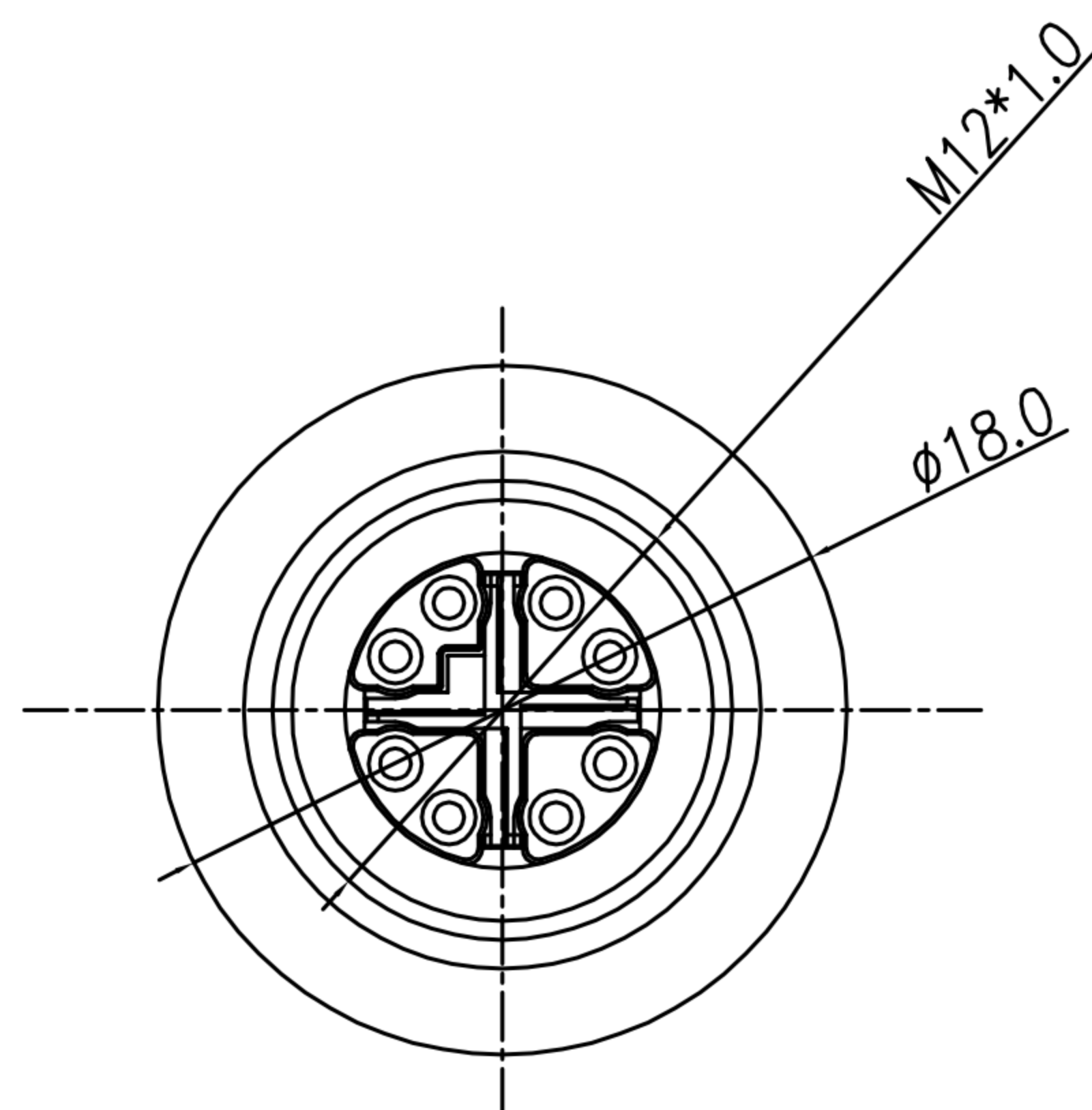
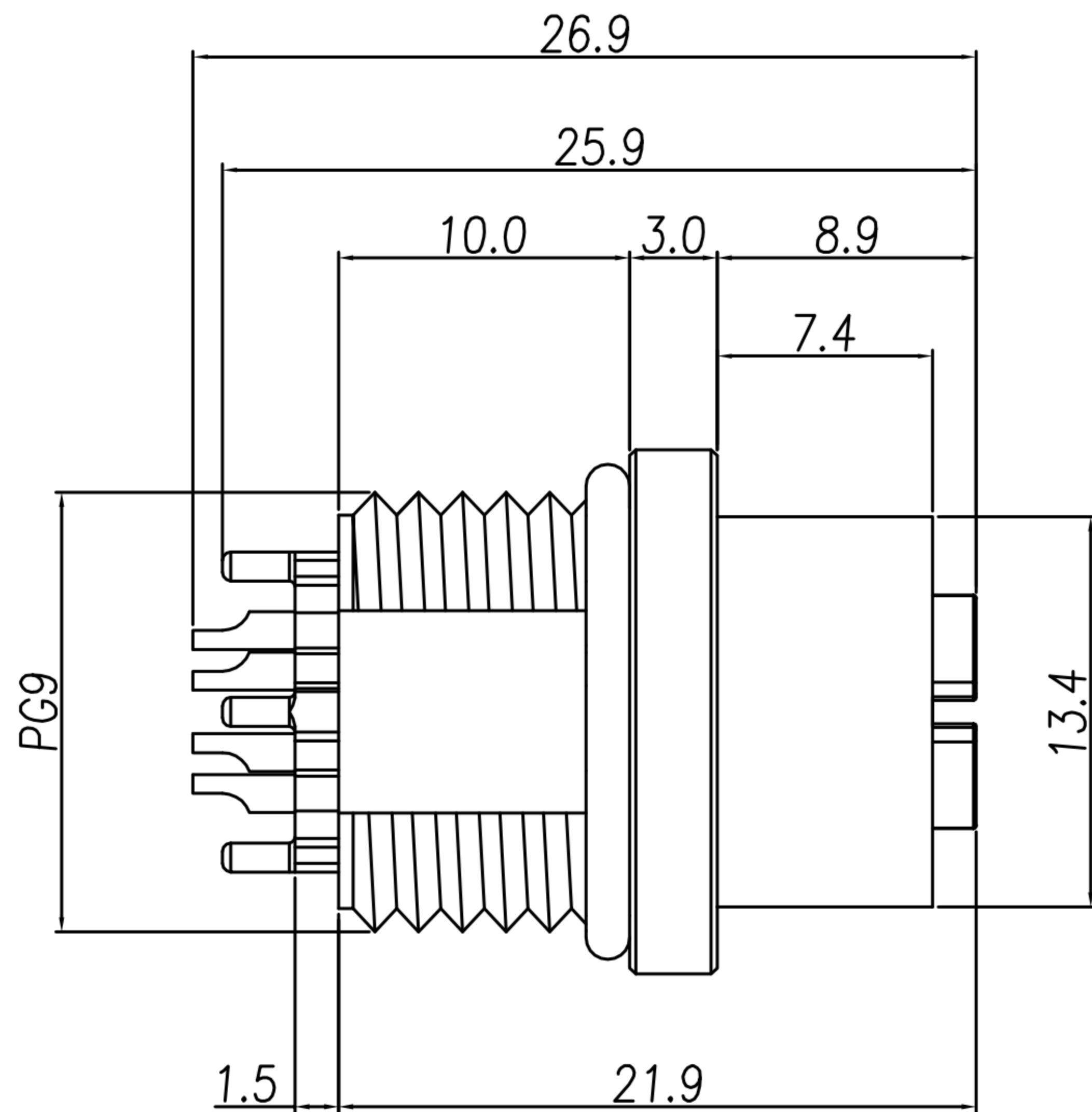
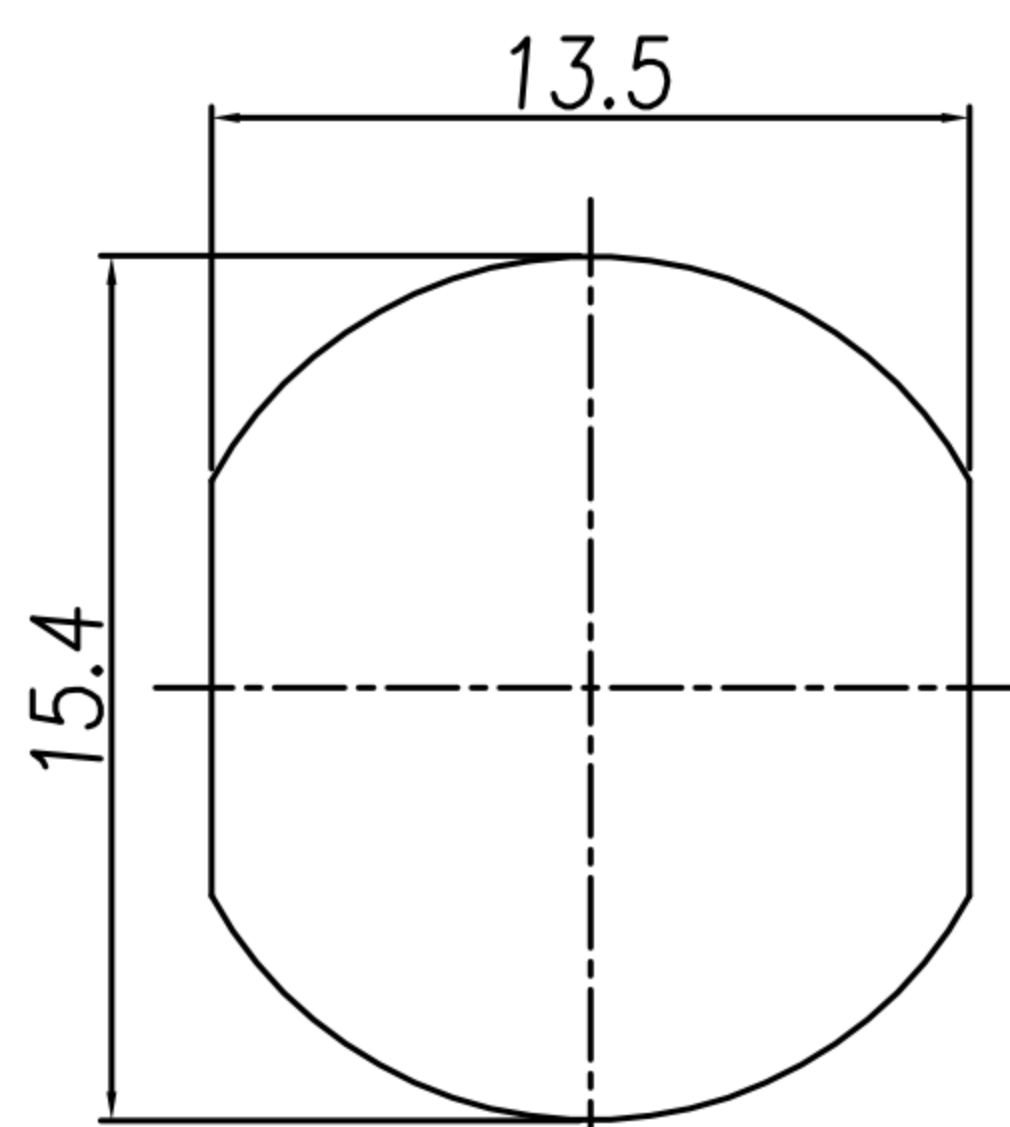

RECOMMEND PANEL CUT-OUT

- MATERIAL :
 - 1-1. HOUSING : PA66 UL94V-0 ; COLOR : BLACK
 - 1-2. CONTACT : BRASS
 - 1-3. NUT : BRASS
 - 1-4. SHELL : BRASS
 - 1-5. O-RING : EPDM
 - 1-6. X-SHELL : Zn ALLOY
- FINISH :
 - 2-1. CONTACT : 10 MICRO INCHES MIN. GOLD PLATED
UNDER PLATE : NICKEL
 - 2-2. NUT : NICKEL PLATED
 - 2-3. SHELL : NICKEL PLATED
 - 2-4. X-SHELL : NICKEL PLATED
- ELECTRICAL SPECIFICATION :
 - 3-1. Rated current : 0.5A
 - 3-2. Rated Voltage : 48V
 - 3-3. Water proof: IPX7
- Environmental :
 - 4-1. Operation Temperature : -40℃~85℃

DRAWN	Ku Chou	APPEND	Fido Weng	UNIT	mm	TOLERANCE		广东科斯达电子科技有限公司 GUANG DONG KE SI DA ELECTRONIC TECHNOLOGY CO., LTD.	TITLE	防水頭 M12 8PIN X-Code (F) 後鎖Pg9 焊線式(圓形/無溝槽)			SHEET	1
CHKD	Emily Suen			SCALE	1:1	.x ±0.20 .xx ±0.10 .xxx ±0.05 .xxxx ±0.03 ANGULA ±1°			PART NO.	WP-08F2-115-11	DWG NO.	QC9375	VERSION	A