

# CUSTOMER DRAWING

REV.	DESCRIPTION	APPVL. BY	DATE	ECN NO.
A	RELEASE	Yeh Chou		
B	ADD PART NO.	Leo	2019/04/03	
C	新增機	Leo	2020/07/30	

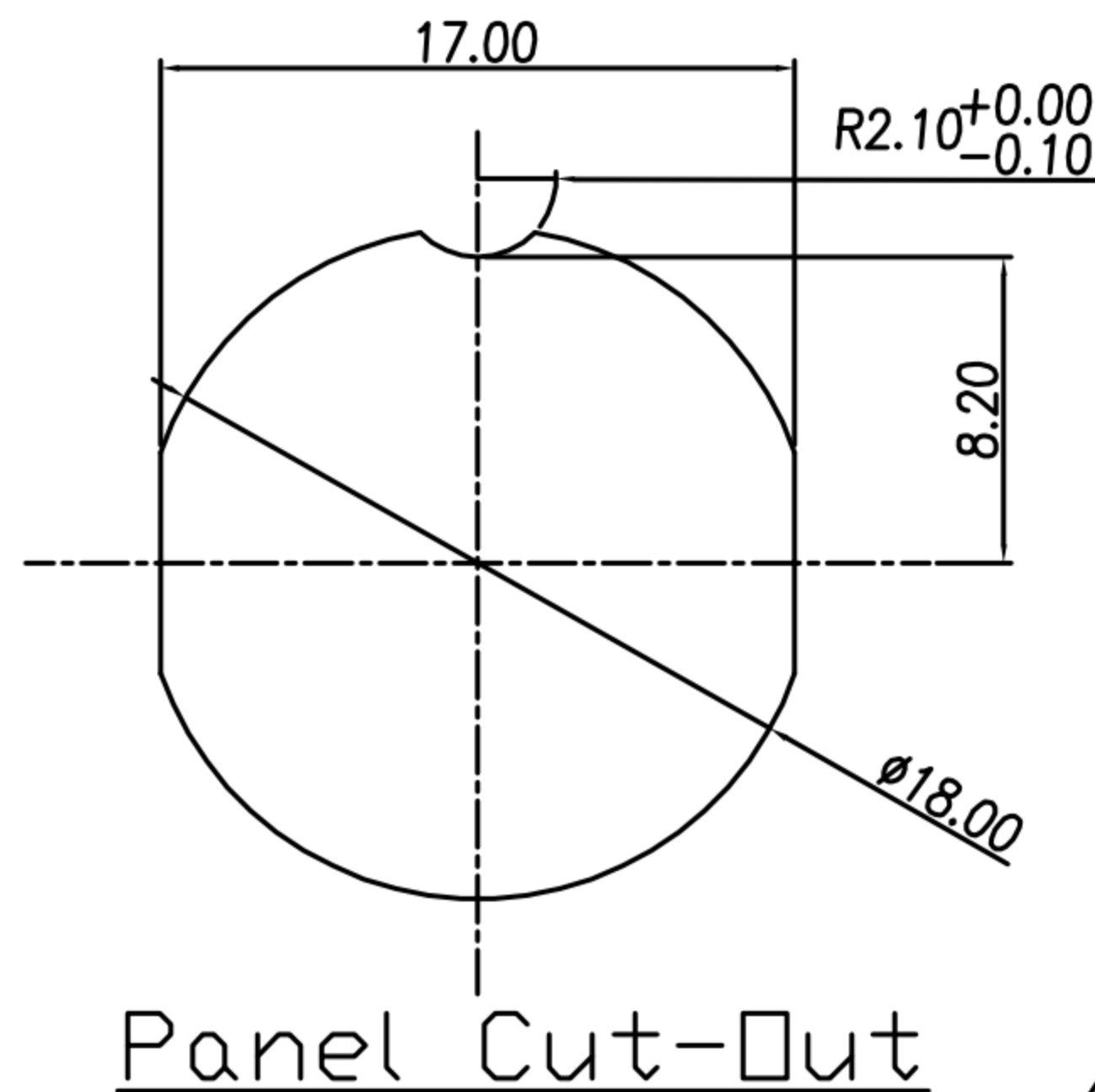
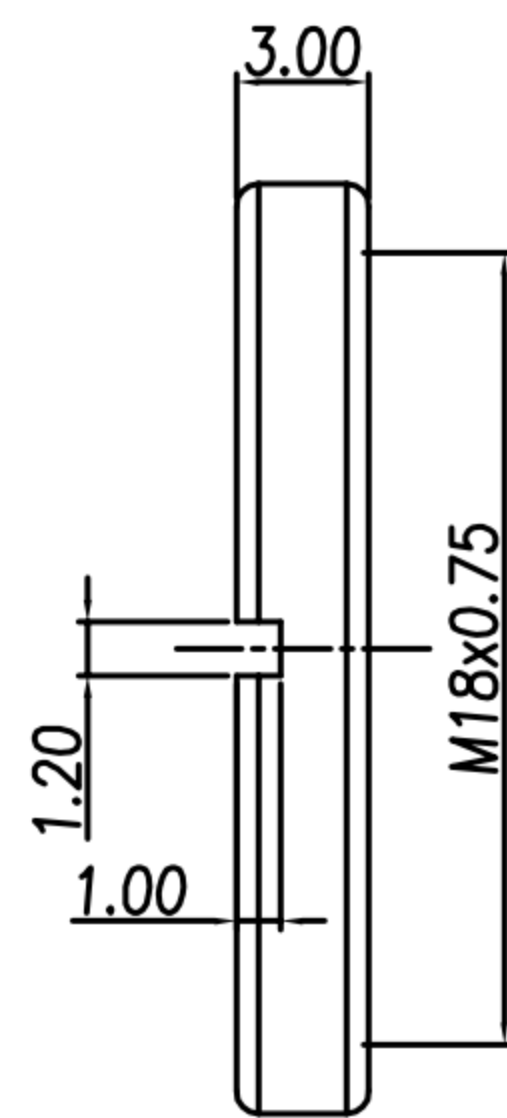
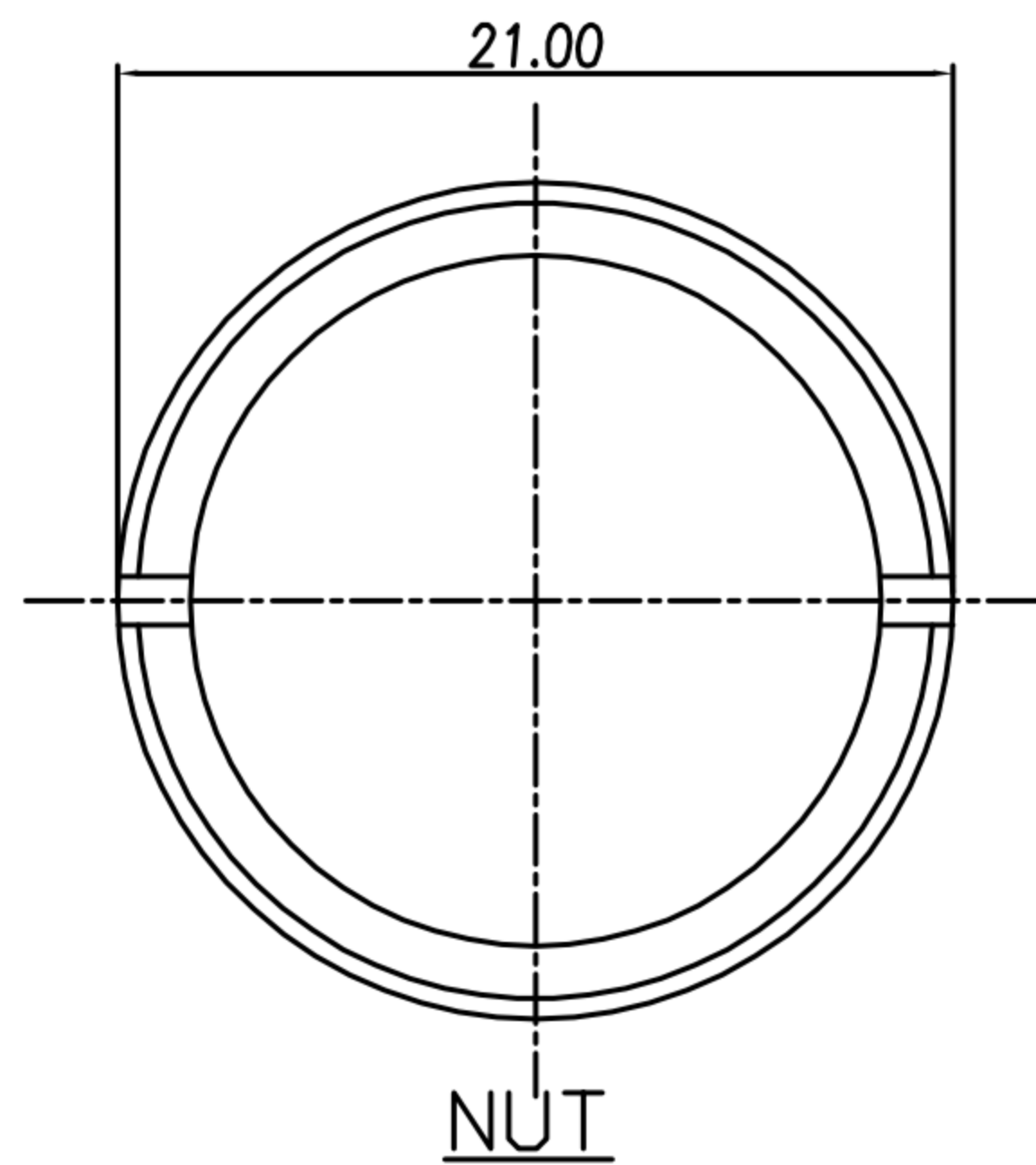
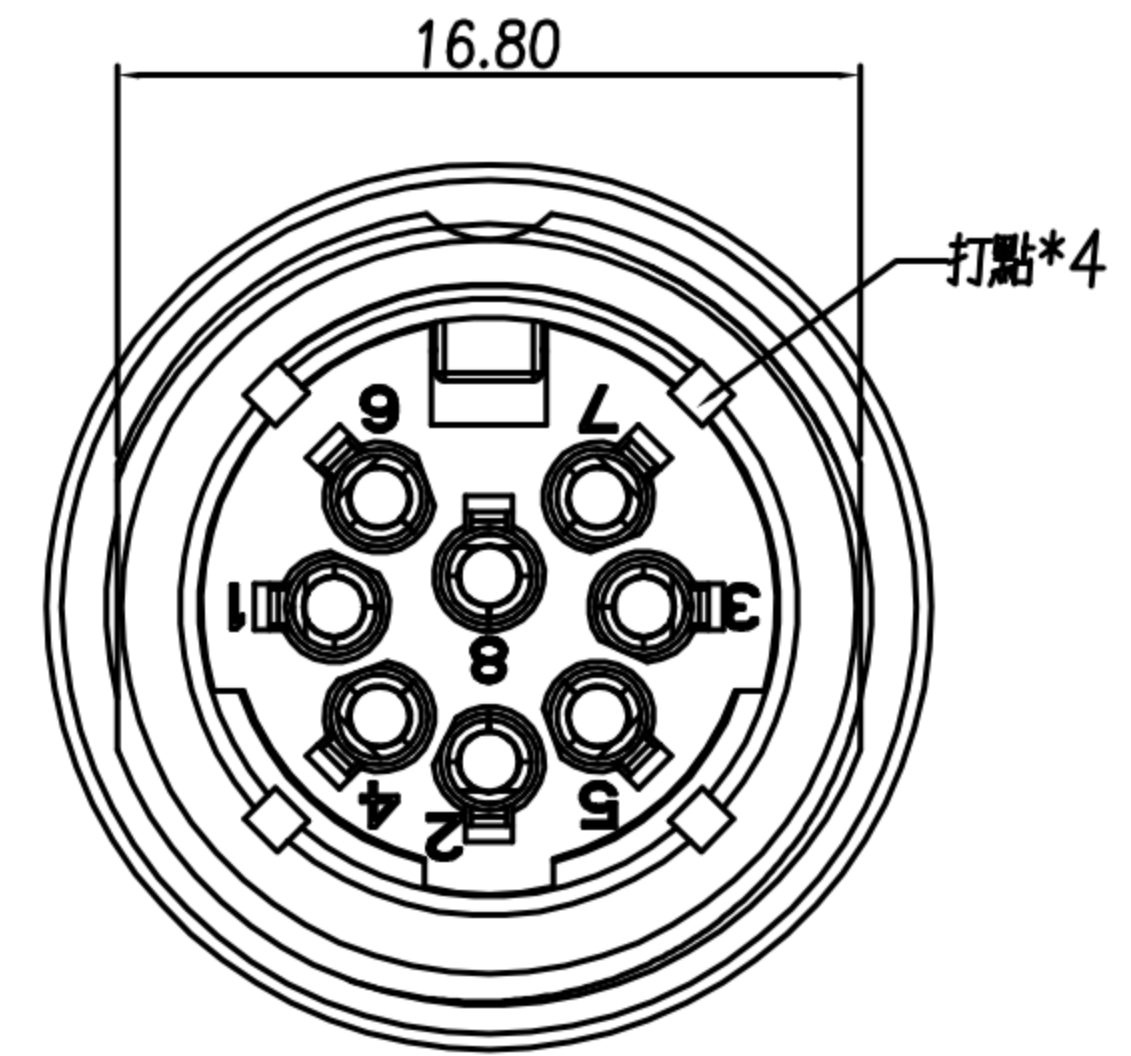
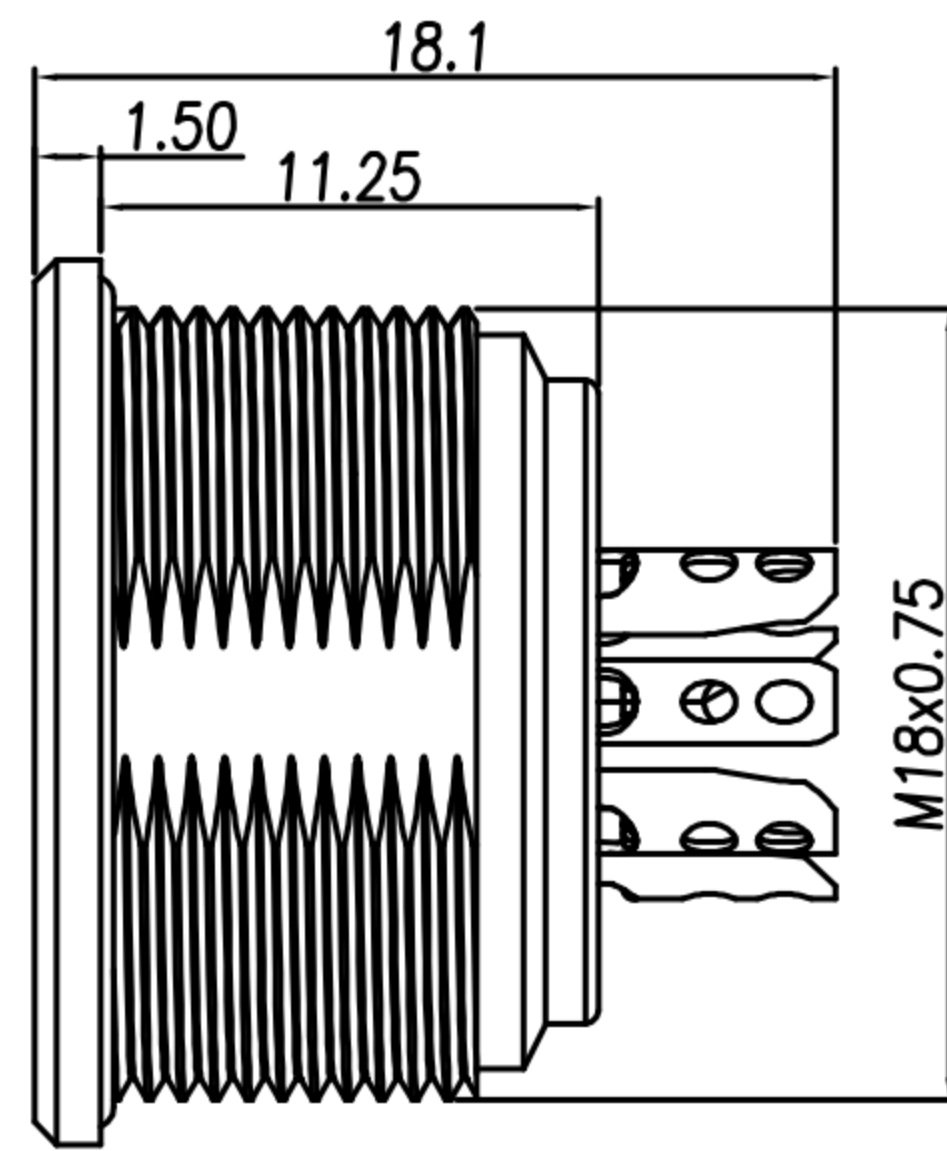
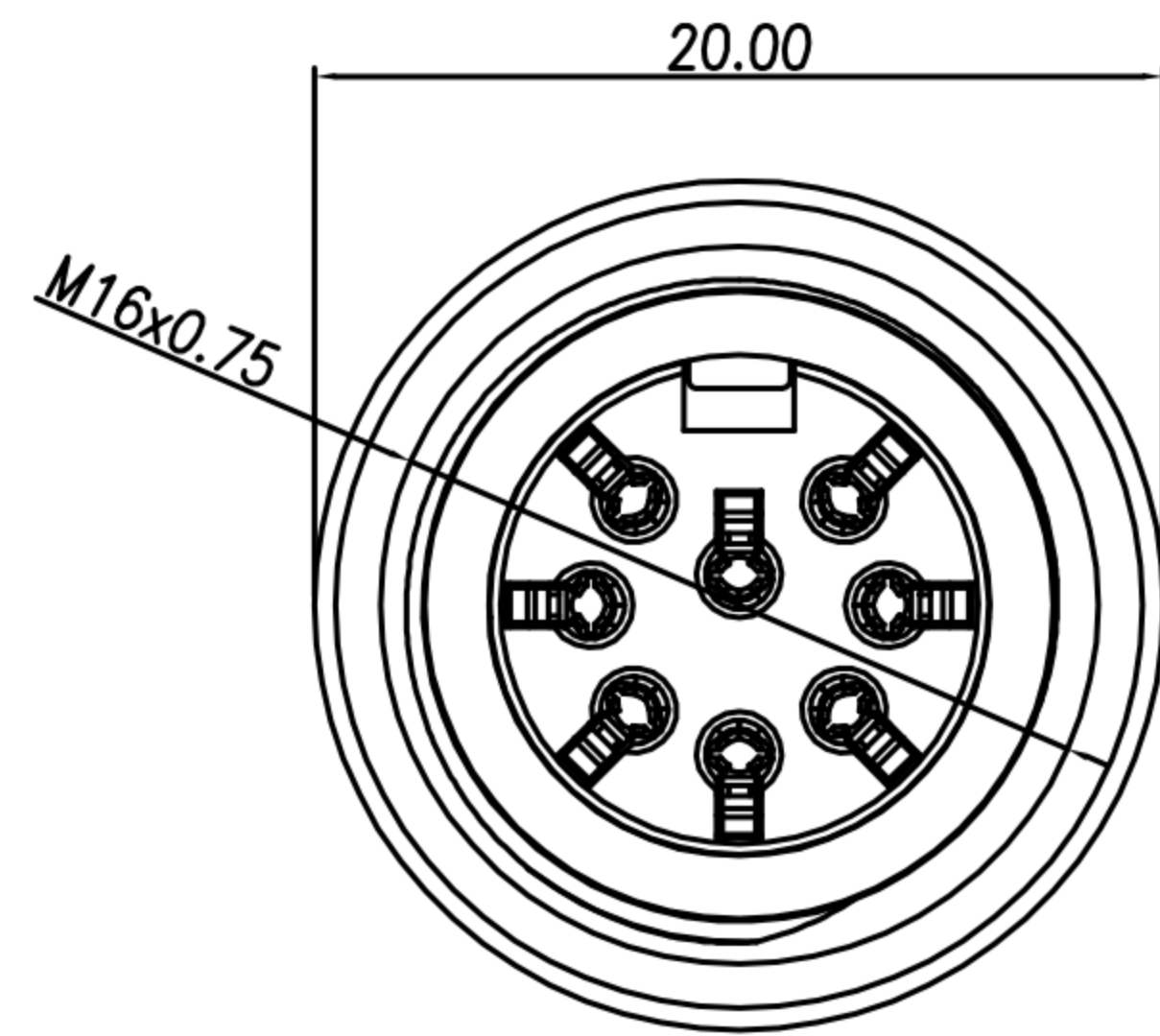

- MATERIAL :
  - 1-1. HOUSING : NYLON UL94V-0 ; COLOR : BLACK
  - 1-2. CONTACT : PHOSPHOR BRONZE
  - 1-3. SHELL : Zn ALLOY
  - 1-4. O-RING : EPDM ; COLOR : BLACK.
  - 1-5. NUT : BRASS
- FINISH :
  - 2-1. CONTACT : GOLD FLASH MICRO INCHES MIN.
  - 2-2. NUT : NICKEL PLTAE.
  - 2-3. SHELL : NICKEL PLTAE.
- ELECTRICAL SPECIFICATION :
  - 3-1. Rated current(40°C) : 5A
  - 3-2. Rated Voltage : 250V
  - 3-3. Water proof : IP67 (in mated condition)
- Environmental :
  - 4-1. Operation Temperature : -40°C~85°C

NUT

Panel Cut-Out

DI-03F2-13-11	DI-04F2-19-11	DI-05F2-16-11	DI-05F2-24-11	DI-06F2-24-11	DI-07F2-23-11	DI-07F2-16-11	DI-08F2-12-11

DRAWN	Yeh Chou	APP'D	Ku Chou	UNIT	mm	TOLERANCE		广东科斯达电子科技有限公司 GUANG DONG KE SI DA ELECTRONIC TECHNOLOGY CO., LTD.	TITLE	Din 8P Female receptacle for rear mounting			SHEET	1
CHK'D	Ku Chou			SCALE	1:1	.x ±0.20 .xx ±0.10 .xxx ±0.05 .xxxx ±0.03 ANGULA ±1°			PART NO.	SEE TABLE A	DWG NO.	QC7926	VERSION	C