

CUSTOMER DRAWING

REV.	DESCRIPTION	APPROVED BY	DATE	ECN NO.
△A	RELEASE	Fido Weng	18/05/09*	
△B				
△C				

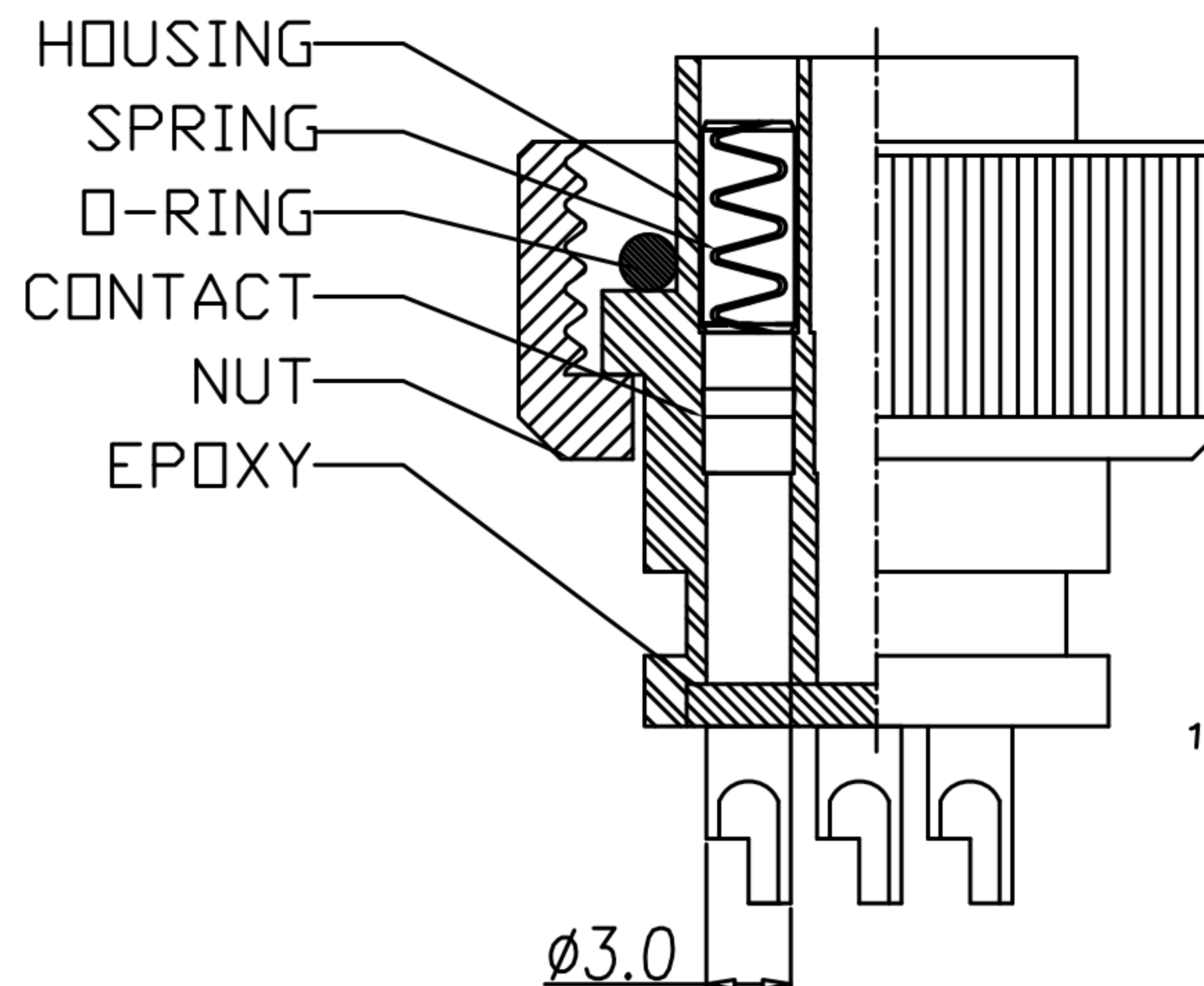

- MATERIAL :
 - 1-1. HOUSING : PBT UL94V-0 ; COLOR : YELLOW
 - 1-2. CONTACT : BRASS
 - 1-3. SPRING : PHOSPHOR BRONZE
 - 1-4. NUT : BRASS
 - 1-5. O-RING : NBR
- FINISH :
 - 2-1. CONTACT : SEE TABLE A
 - UNDER PLATE : NICKEL
 - 2-2. SPRING : MATTE TIN PLATED
 - 2-3. NUT : NICKEL PLATED
- ELECTRICAL SPECIFICATION :
 - 3-1. Rated current : 20A
 - 3-2. Rated voltage : 250V
 - 3-3. Water proof : IP68
- Environmental :
 - 4-1. Operation Temperature : -20℃~85℃

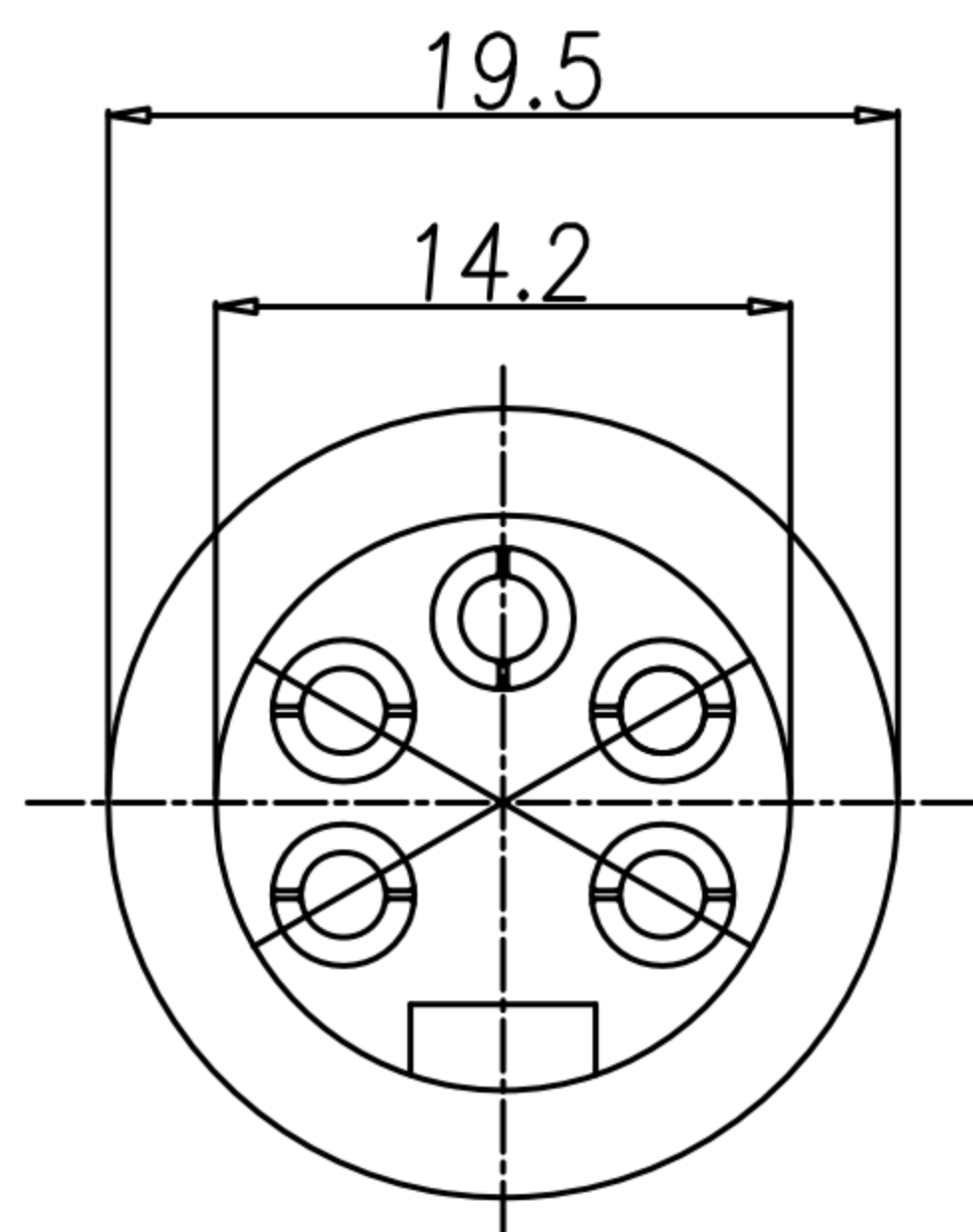
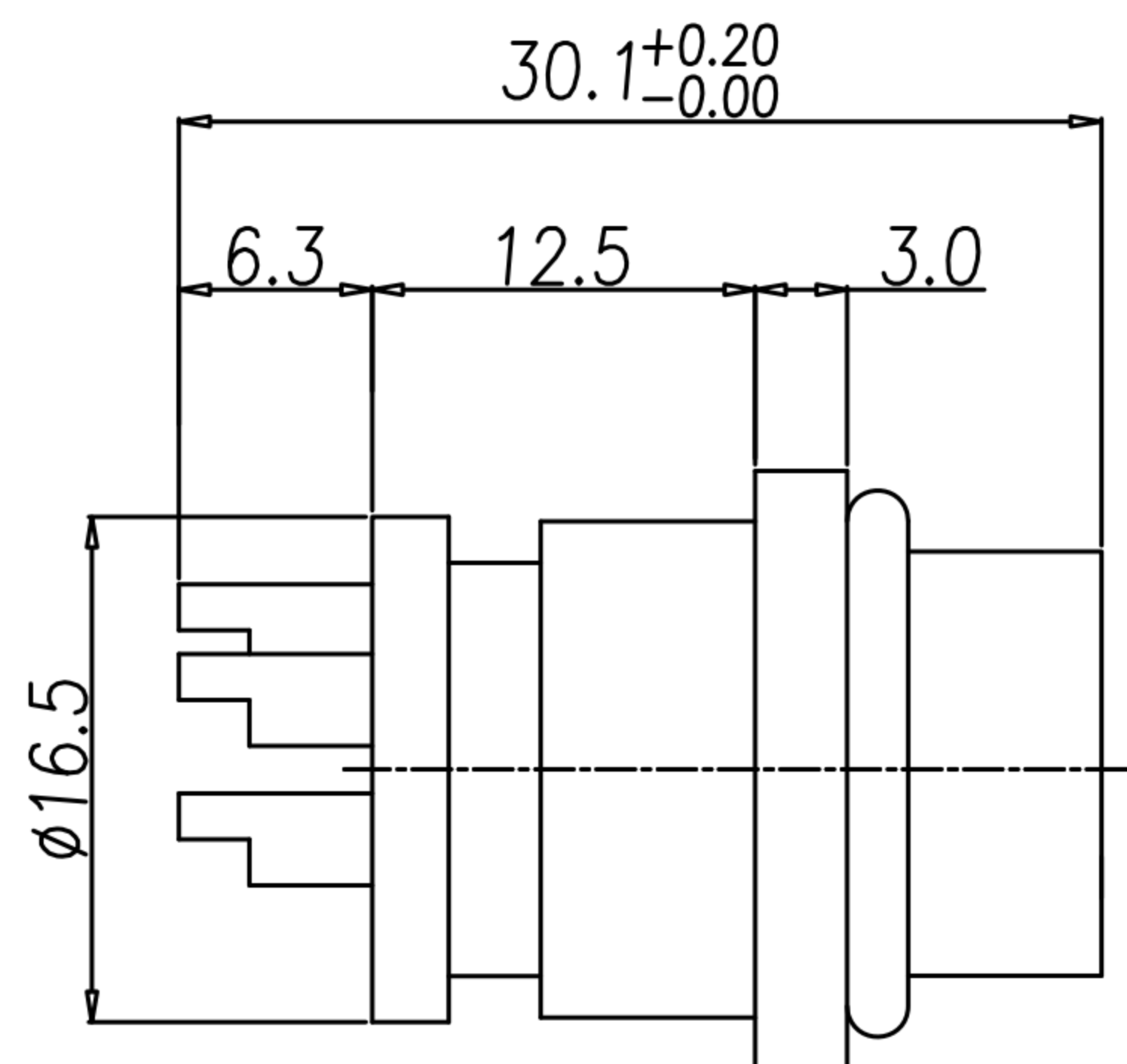
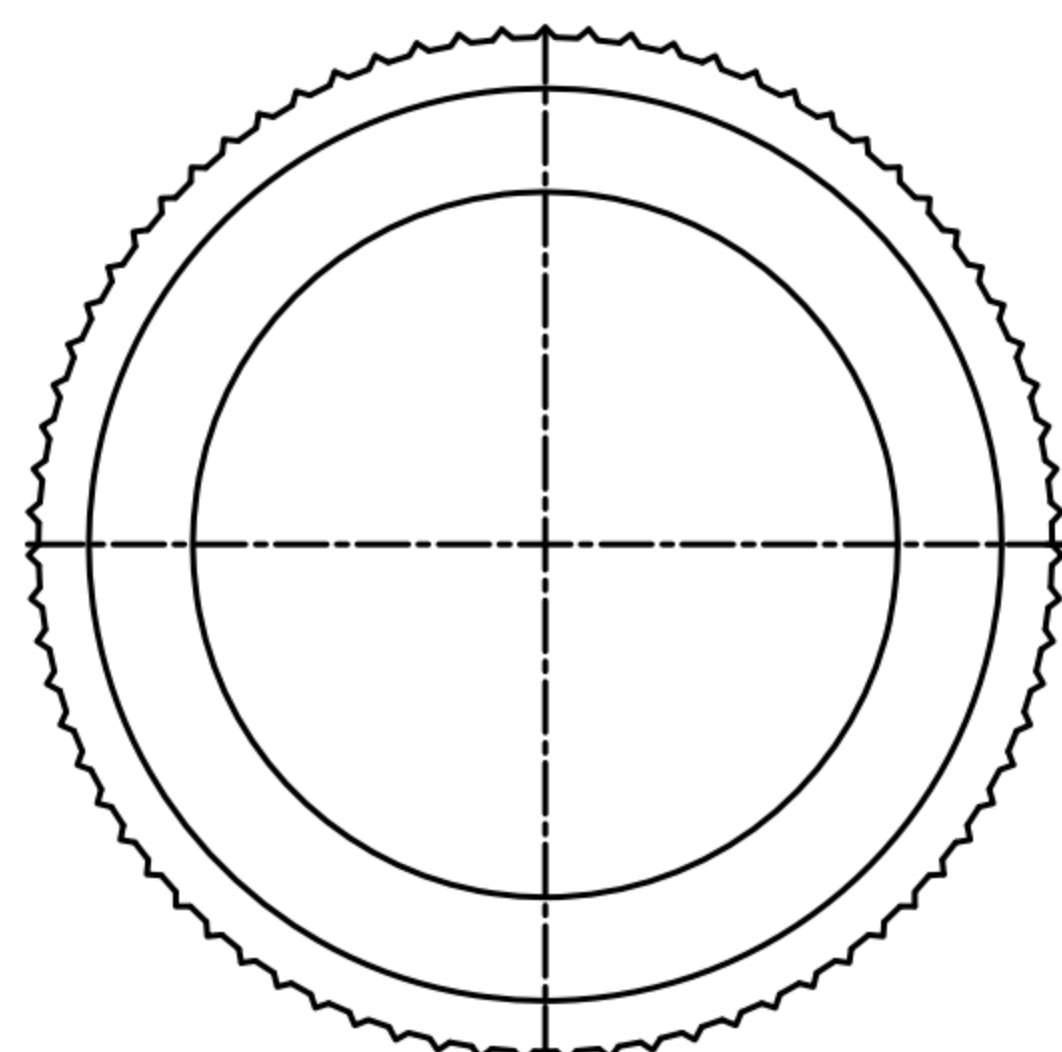

NUT

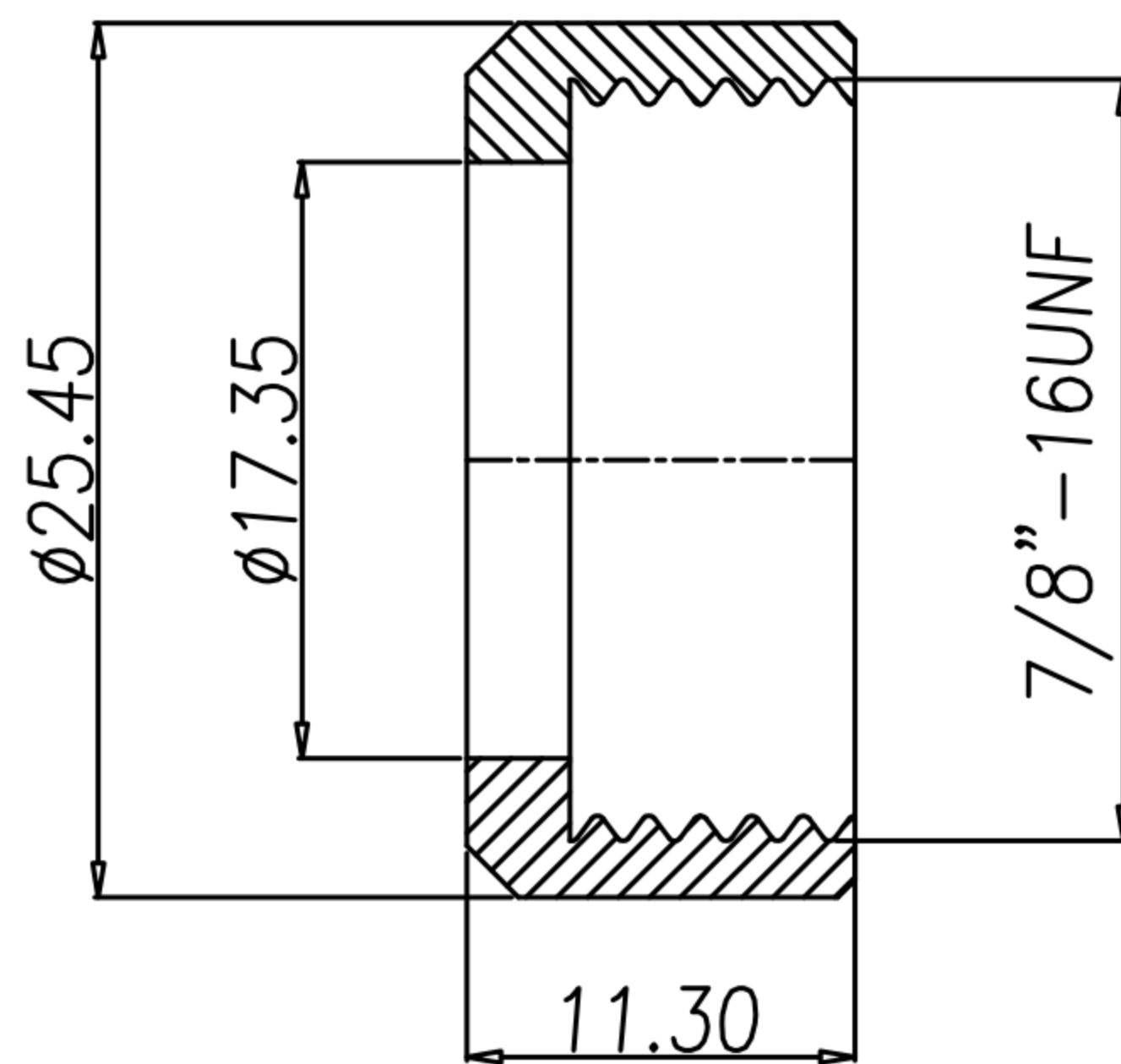
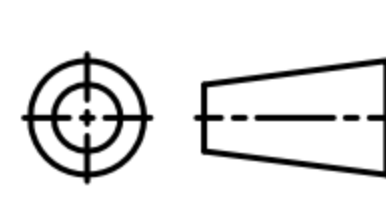

TABLE A

3PIN		3PIN		4PIN		5PIN	
WP-03F2-32		WP-03F2-14 WP-03F2-80-11		WP-04F2-46 WP-04F2-285-11		WP-05F2-21 WP-05F2-206-11	
WP-03F2-32	30u" GOLD PLATED						
WP-05F2-21	30u" GOLD PLATED	WP-05F2-206-11	GOLD FLASH PLATED				
WP-04F2-46	30u" GOLD PLATED	WP-04F2-285-11	GOLD FLASH PLATED				
WP-03F2-14	30u" GOLD PLATED	WP-03F2-80-11	GOLD FLASH PLATED				
PART No.	FINISH	PART No.	FINISH				

DRAWN	Mark Kao	APP'D	Ku Chou	UNIT	mm	TOLERANCE
CHK'D	Emily Suen			SCALE	1:1	.x ±0.25 .xx ±0.20 .xxx ±0.10 .xxxx ±0.03 ANGULA ±1°



广东科斯达电子科技有限公司
GUANG DONG KE SI DA ELECTRONIC TECHNOLOGY CO., LTD.

TITLE	防水頭 7/8" (F) 焊線成型式			SHEET	1/1
PART NO.	SEE TABLE A	DWG NO.	QC2813	VERSION	A