

CUSTOMER DRAWING

REV.	DESCRIPTION	APPROVED BY	DATE	ECN NO.
△A	RELEASE	Fido Weng	18/05/09*	
△B				
△C				

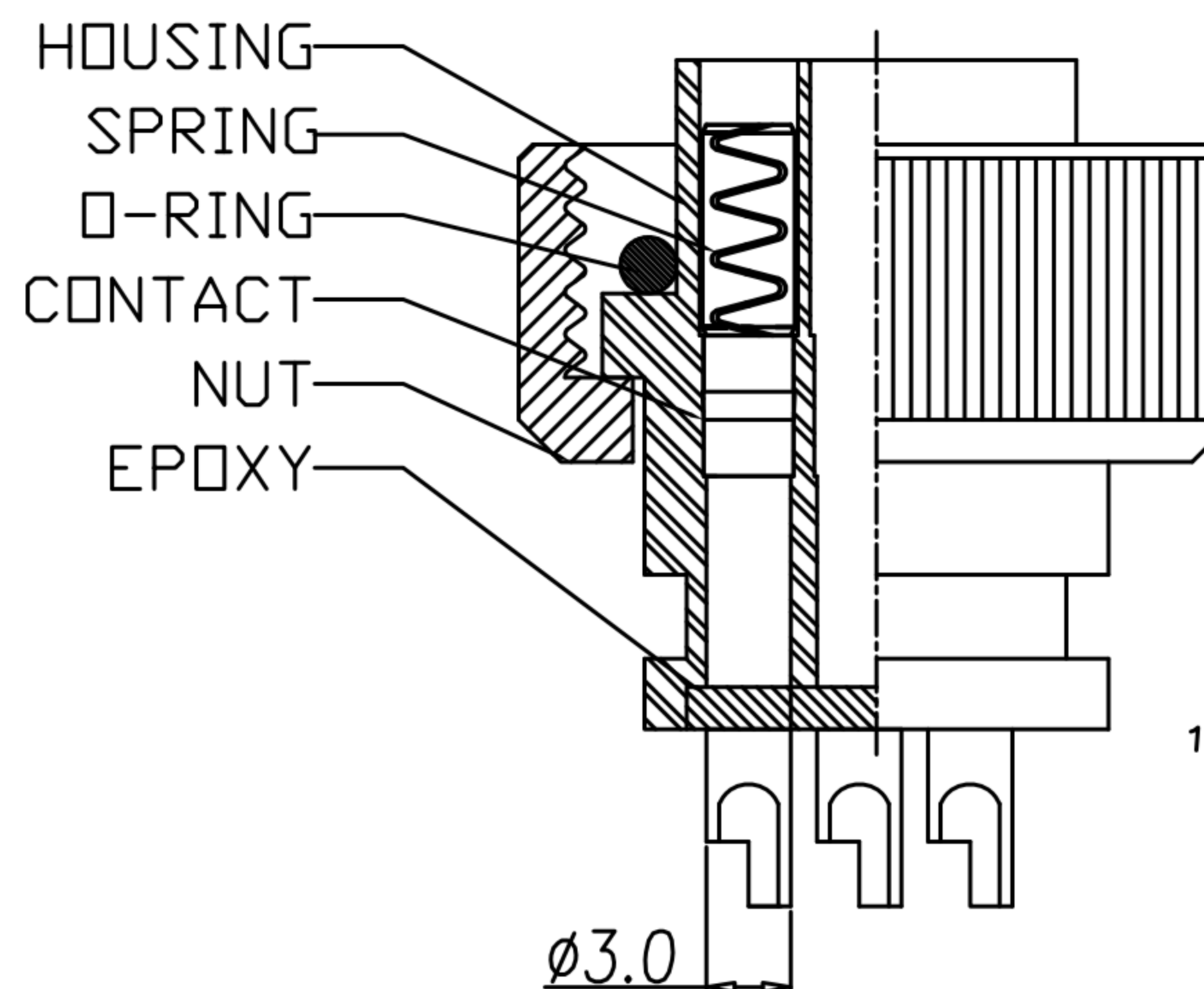

- MATERIAL :
 - 1-1. HOUSING : PBT UL94V-0 ; COLOR : YELLOW
 - 1-2. CONTACT : BRASS
 - 1-3. SPRING : PHOSPHOR BRONZE
 - 1-4. NUT : BRASS
 - 1-5. O-RING : NBR
- FINISH :
 - 2-1. CONTACT : SEE TABLE A
UNDER PLATE : NICKEL
 - 2-2. SPRING : MATTE TIN PLATED
 - 2-3. NUT : NICKEL PLATED
- ELECTRICAL SPECIFICATION :
 - 3-1. Rated current : 20A
 - 3-2. Rated voltage : 250V
 - 3-3. Water proof : IP68
- Environmental :
 - 4-1. Operation Temperature : -20℃~85℃

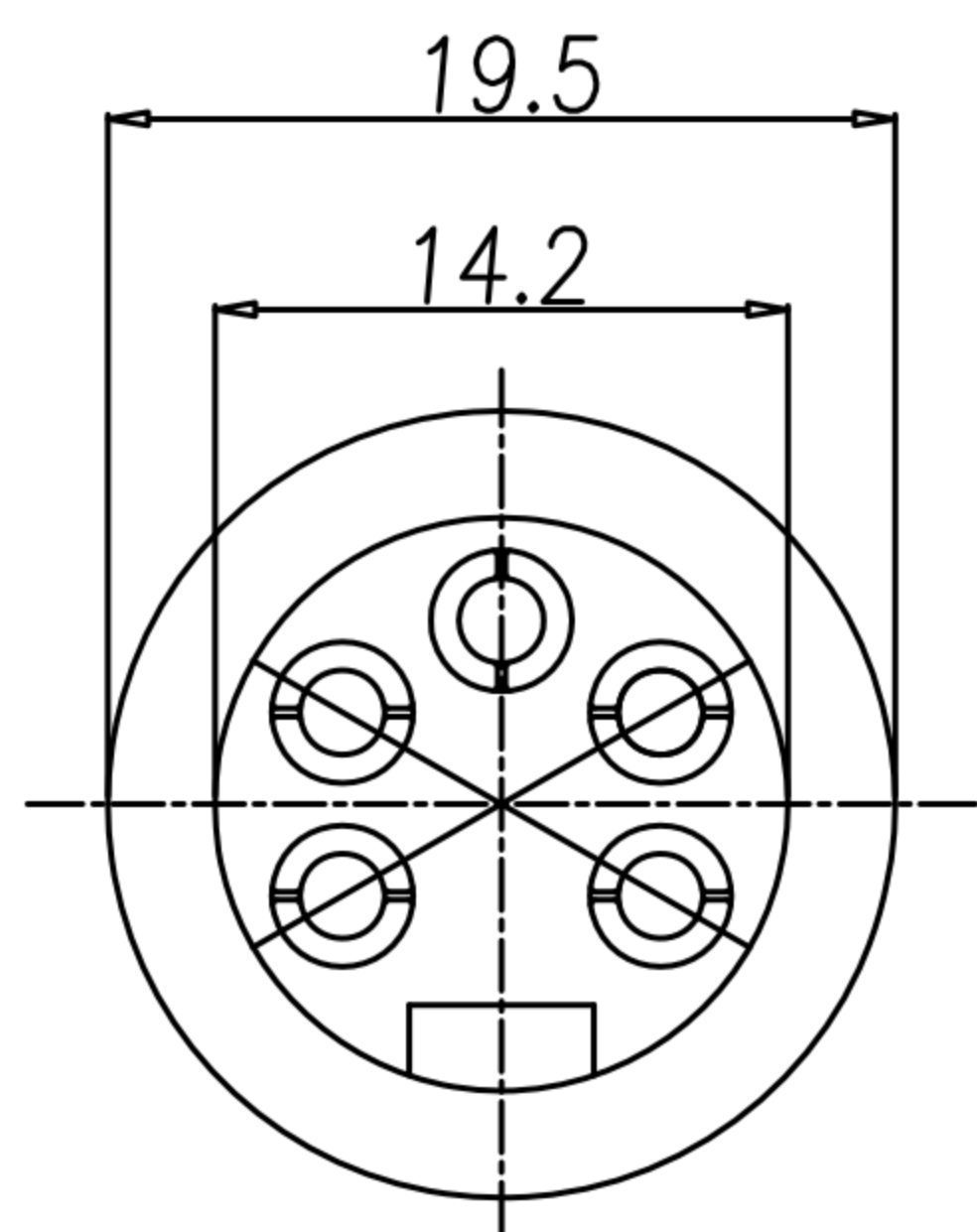
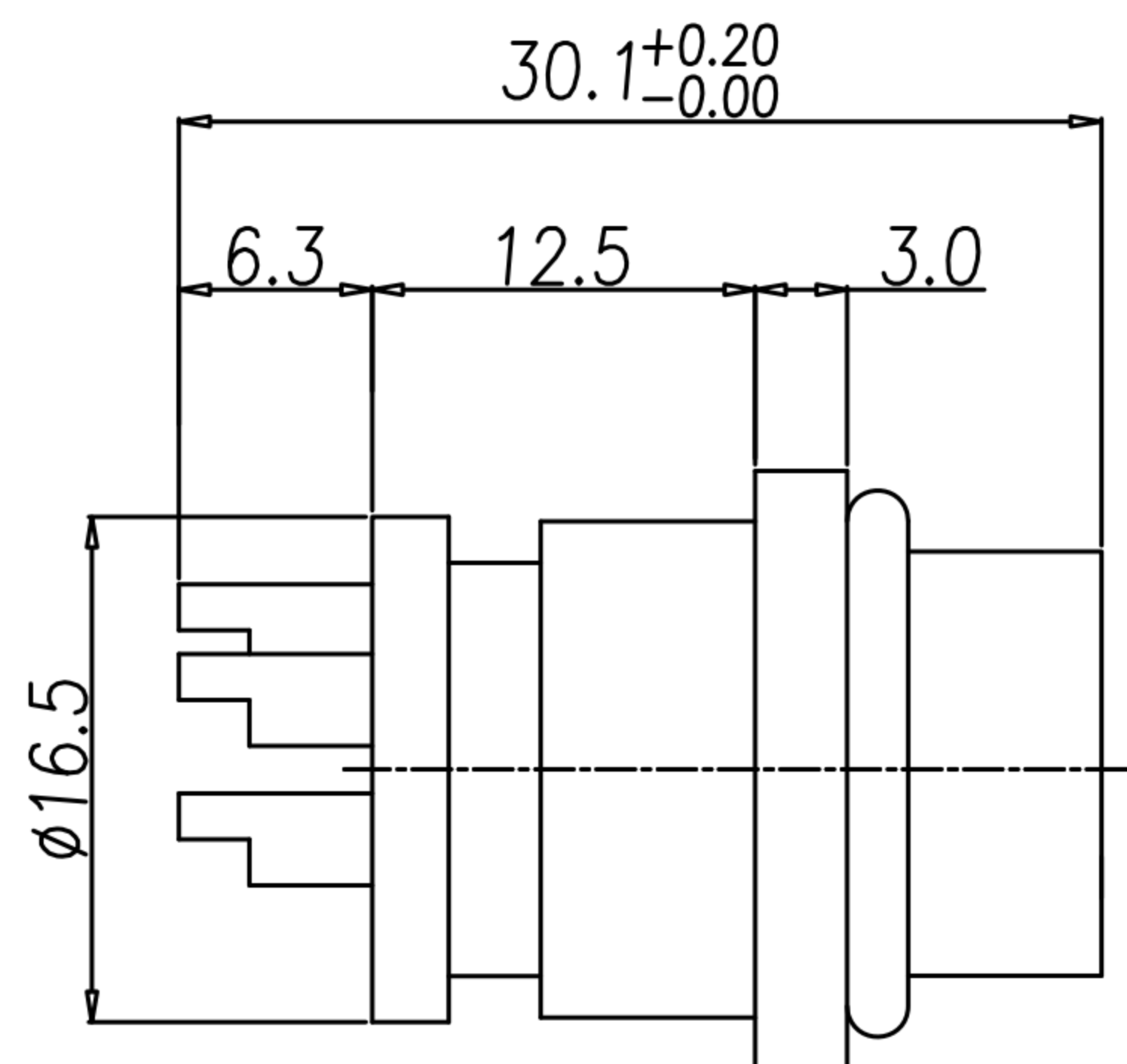
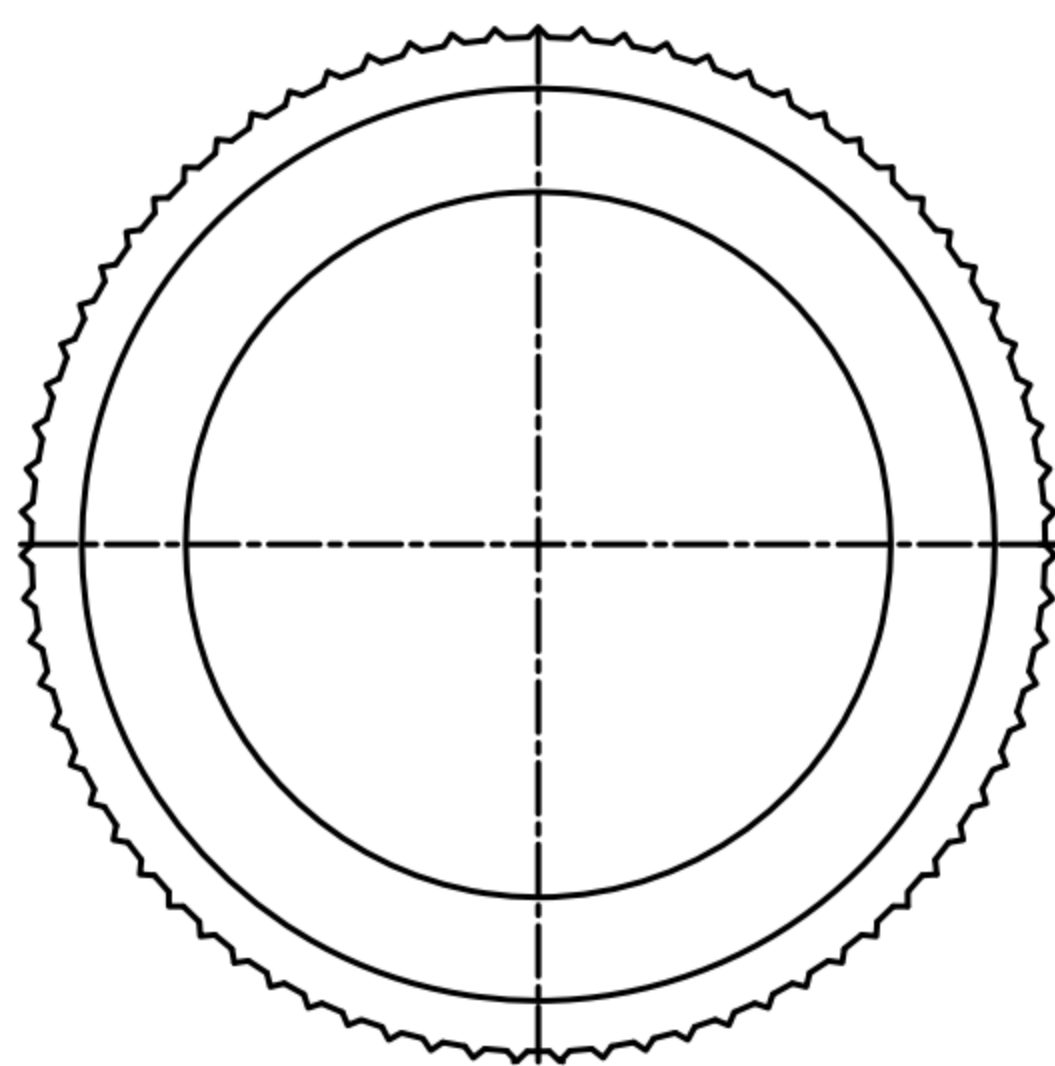

NUT

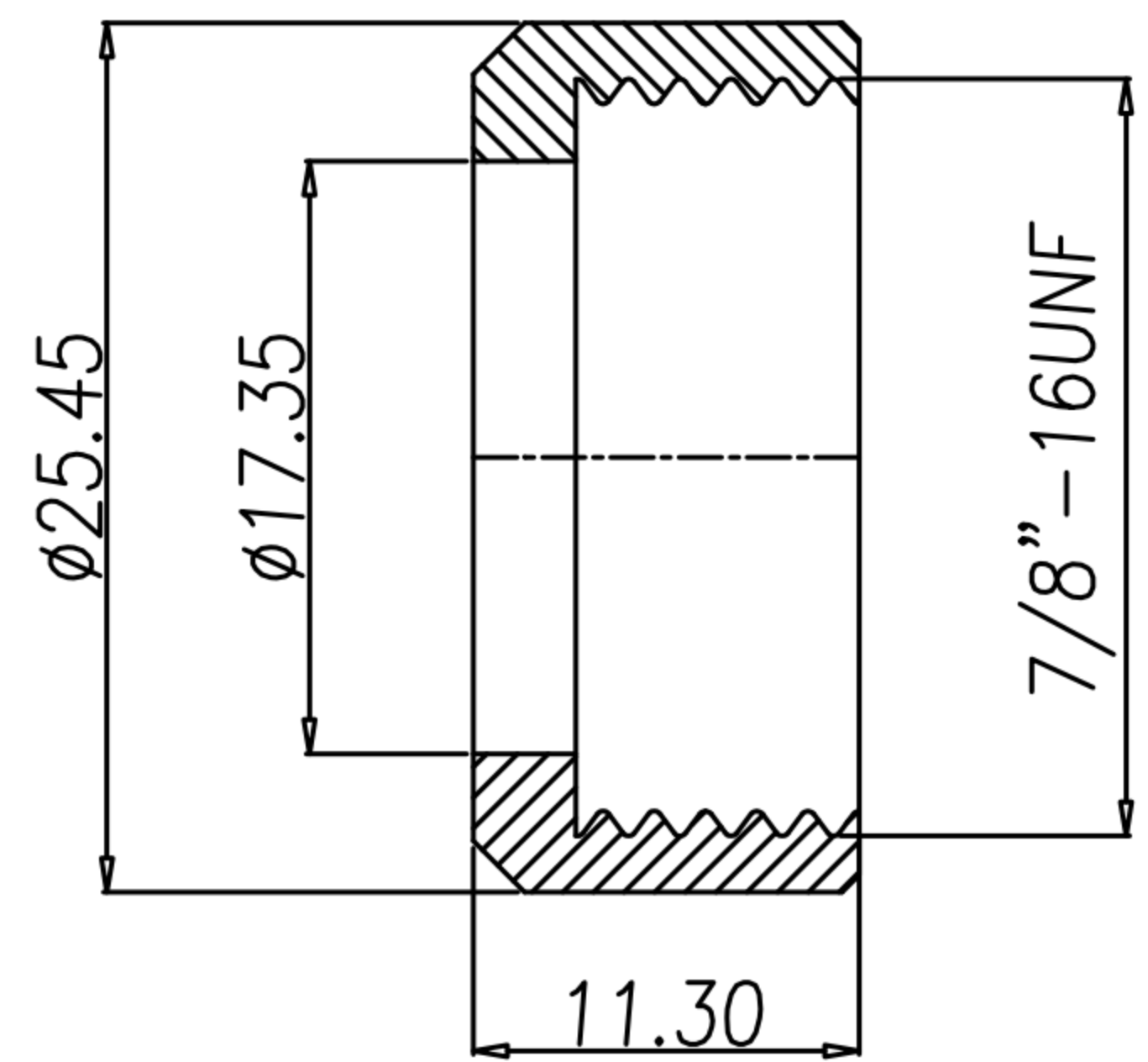

TABLE A

3PIN	3PIN	4PIN	5PIN
WP-03F2-32	WP-03F2-14 WP-03F2-80-11	WP-04F2-46 WP-04F2-285-11	WP-05F2-21 WP-05F2-206-11
WP-03F2-32	30u" GOLD PLATED		
WP-05F2-21	30u" GOLD PLATED	WP-05F2-206-11	GOLD FLASH PLATED
WP-04F2-46	30u" GOLD PLATED	WP-04F2-285-11	GOLD FLASH PLATED
WP-03F2-14	30u" GOLD PLATED	WP-03F2-80-11	GOLD FLASH PLATED
PART No.	FINISH	PART No.	FINISH

DRAWN	Mark Kao	APP'D	Ku Chou	UNIT	mm	TOLERANCE			广东科斯达电子科技有限公司 GUANG DONG KE SI DA ELECTRONIC TECHNOLOGY CO., LTD.	TITLE	防水頭 7/8" (F) 焊線成型式			SHEET	1 VERSION A
CHK'D	Emily Suen			SCALE	1:1					PART NO.	SEE TABLE A	DWG NO.	QC2813		