

CUSTOMER DRAWING

REV.	DESCRIPTION	APPROVED BY	DATE	ECN NO.
△A	RELEASE	Emily Suen		
△B				
△C				
△D				

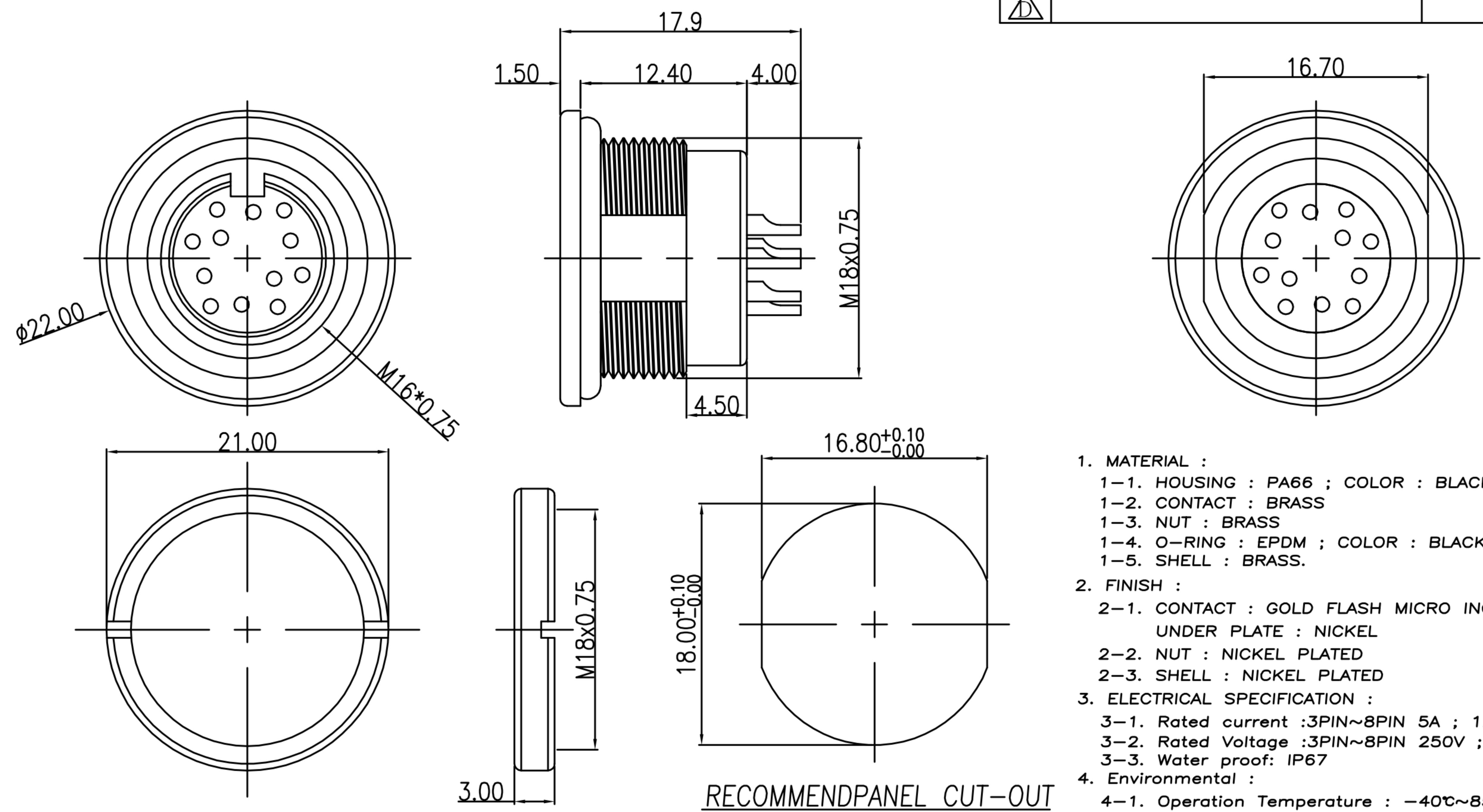

- MATERIAL :
 - 1-1. HOUSING : PA66 ; COLOR : BLACK.
 - 1-2. CONTACT : BRASS
 - 1-3. NUT : BRASS
 - 1-4. O-RING : EPDM ; COLOR : BLACK
 - 1-5. SHELL : BRASS.
- FINISH :
 - 2-1. CONTACT : GOLD FLASH MICRO INCHES MIN.
UNDER PLATE : NICKEL
 - 2-2. NUT : NICKEL PLATED
 - 2-3. SHELL : NICKEL PLATED
- ELECTRICAL SPECIFICATION :
 - 3-1. Rated current : 3PIN~8PIN 5A ; 12PIN~14PIN 3A
 - 3-2. Rated Voltage : 3PIN~8PIN 250V ; 12PIN~14PIN 60V
 - 3-3. Water proof: IP67
- Environmental :
 - 4-1. Operation Temperature : -40℃~85℃

DI-03F2-16-11	DI-04F2-22-11	DI-05F2-27-11	DI-05F2-19-11	DI-06F2-27-11	DI-07F2-20-11	DI-07F2-19-11	DI-08F2-17-11	DI-12F2-16-11	DI-14F2-02-11