

CUSTOMER DRAWING

REV.	DESCRIPTION	APPROVED BY	DATE	ECN NO.
△A	RELEASE	Fido Weng	13/02/17*	
△B				
△C				

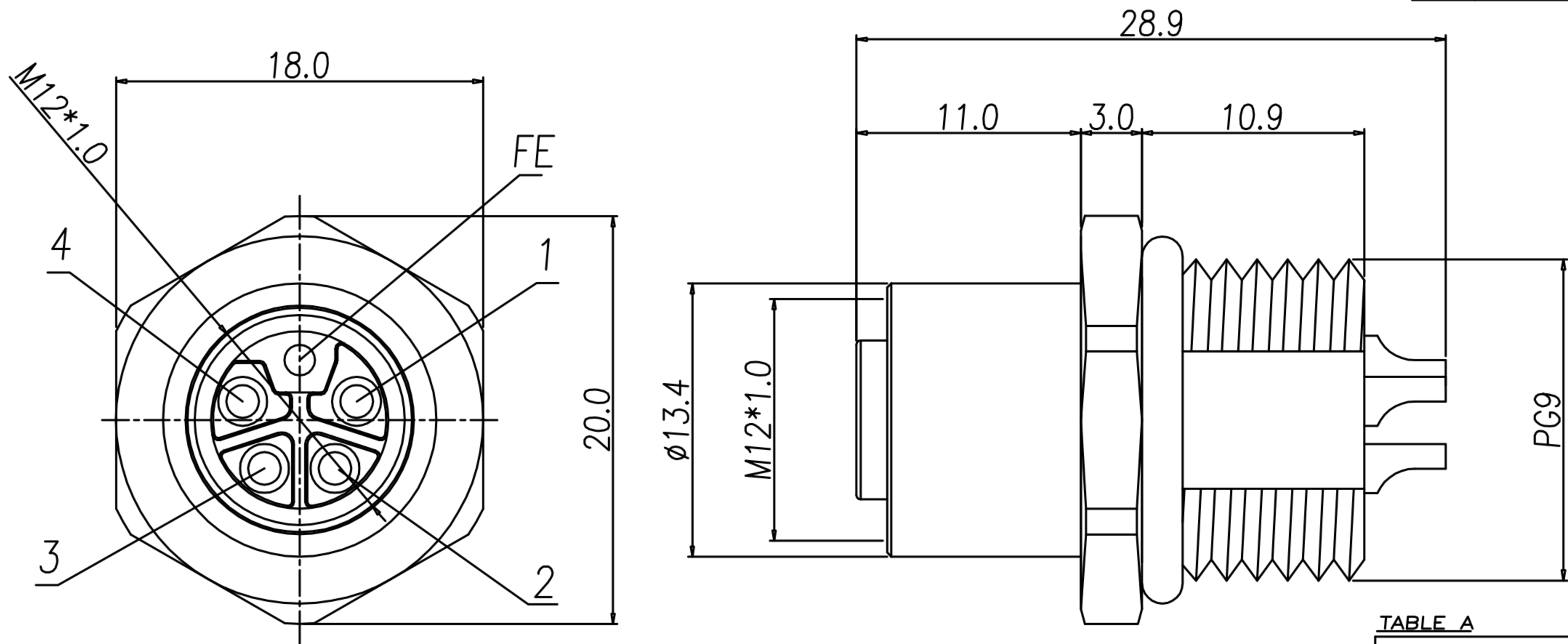
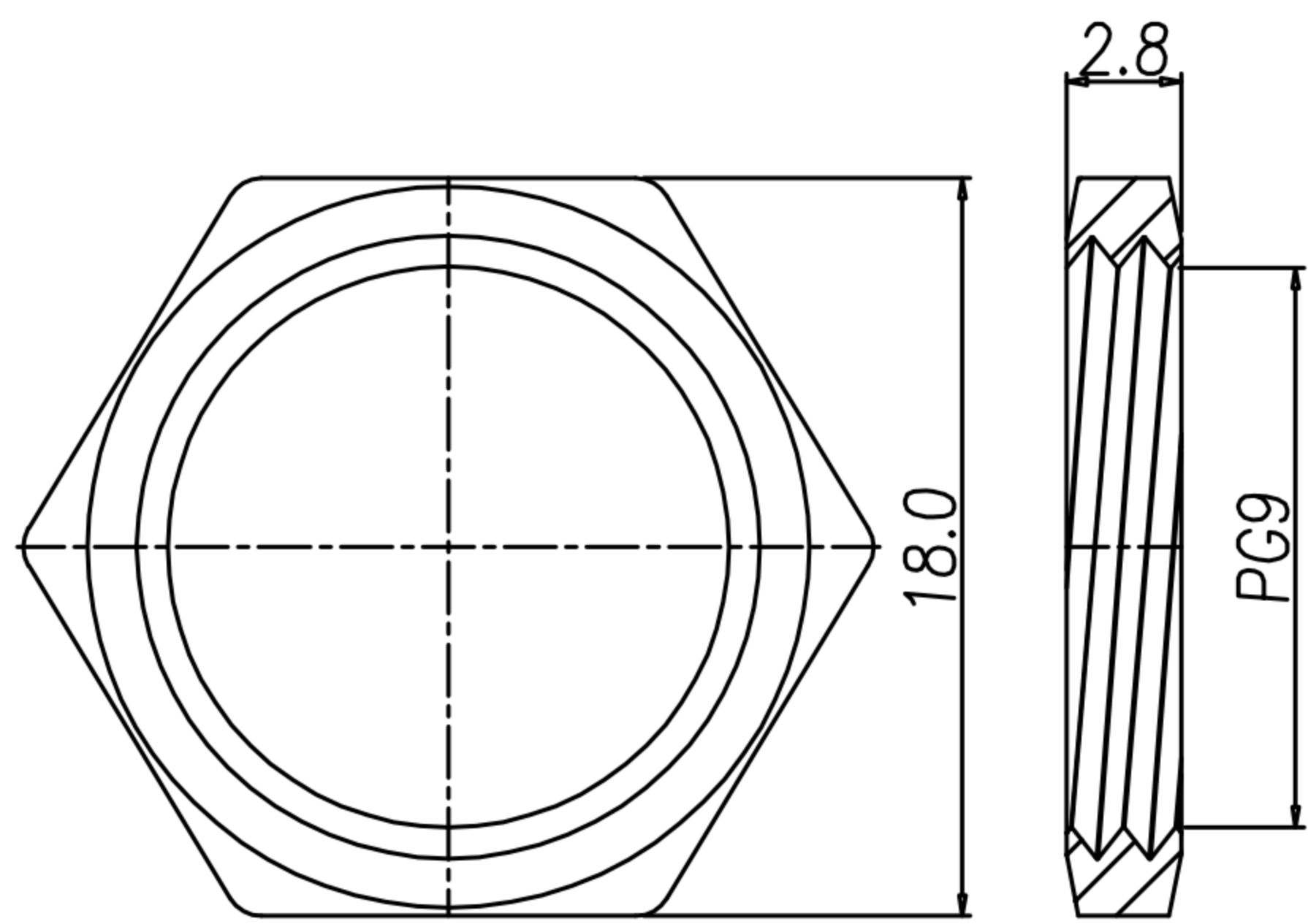
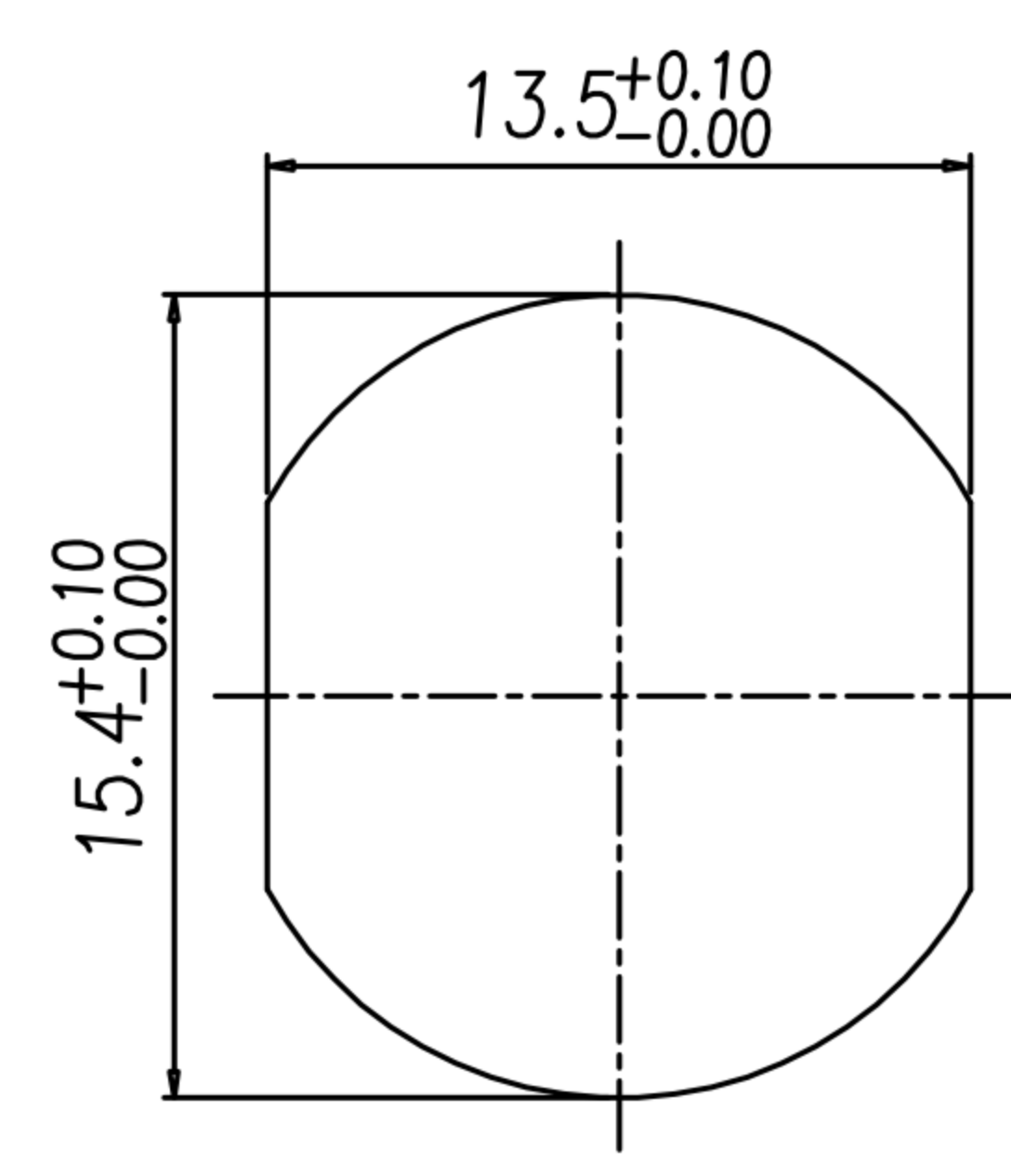

TABLE A

PART No.	MATERIAL(SHELL & NUT)	FINISH(SHELL & NUT)	FINISH(CONTACT)
WP-05F2-202-11	STAINLESS STEEL 316	-	10u" GOLD PLATED
WP-05F2-168-11	BRASS	NICKEL PLATED	GOLD FLASH PLATED



NUT



RECOMMEND PANEL CUT-OUT

1. MATERIAL :
 - 1-1. HOUSING : PA66 UL94V-0 ; COLOR : BLACK
 - 1-2. CONTACT : BRASS
 - 1-3. NUT : SEE TABLE A
 - 1-4. SHELL : SEE TABLE A
 - 1-5. O-RING : EPDM
2. FINISH :
 - 2-1. CONTACT : SEE TABLE A
UNDER PLATE : NICKEL
 - 2-2. NUT : SEE TABLE A
 - 2-3. SHELL : SEE TABLE A
3. ELECTRICAL SPECIFICATION :
 - 3-1. Rated current : 16A
 - 3-2. Rated voltage : 63V
 - 3-3. Water proof : IP67/68
4. Environmental :
 - 4-1. Operation Temperature : -40℃~85℃

DRAWN	Ku Chou	APPEND	Emily Suen	UNIT	mm	TOLERANCE		广东科斯达电子科技有限公司 GUANG DONG KE SI DA ELECTRONIC TECHNOLOGY CO., LTD.	TITLE	M12 5PIN (4+FE) L-CODE (F) 後鎖PG9焊線式			SHEET	1
CHKD	Emily Suen			SCALE	1:1	.x ±0.20 .xx ±0.10 .xxx ±0.05 .xxxx ±0.03 ANGULA ±1°			PART NO.	SEE TABLE A	DWG NO.	QC9000	VERSION	A