

CUSTOMER DRAWING

REV.	DESCRIPTION	APPROVED BY	DATE	ECN NO.
A	RELEASE	Emily Suen	23/08/12'	
B				
C				

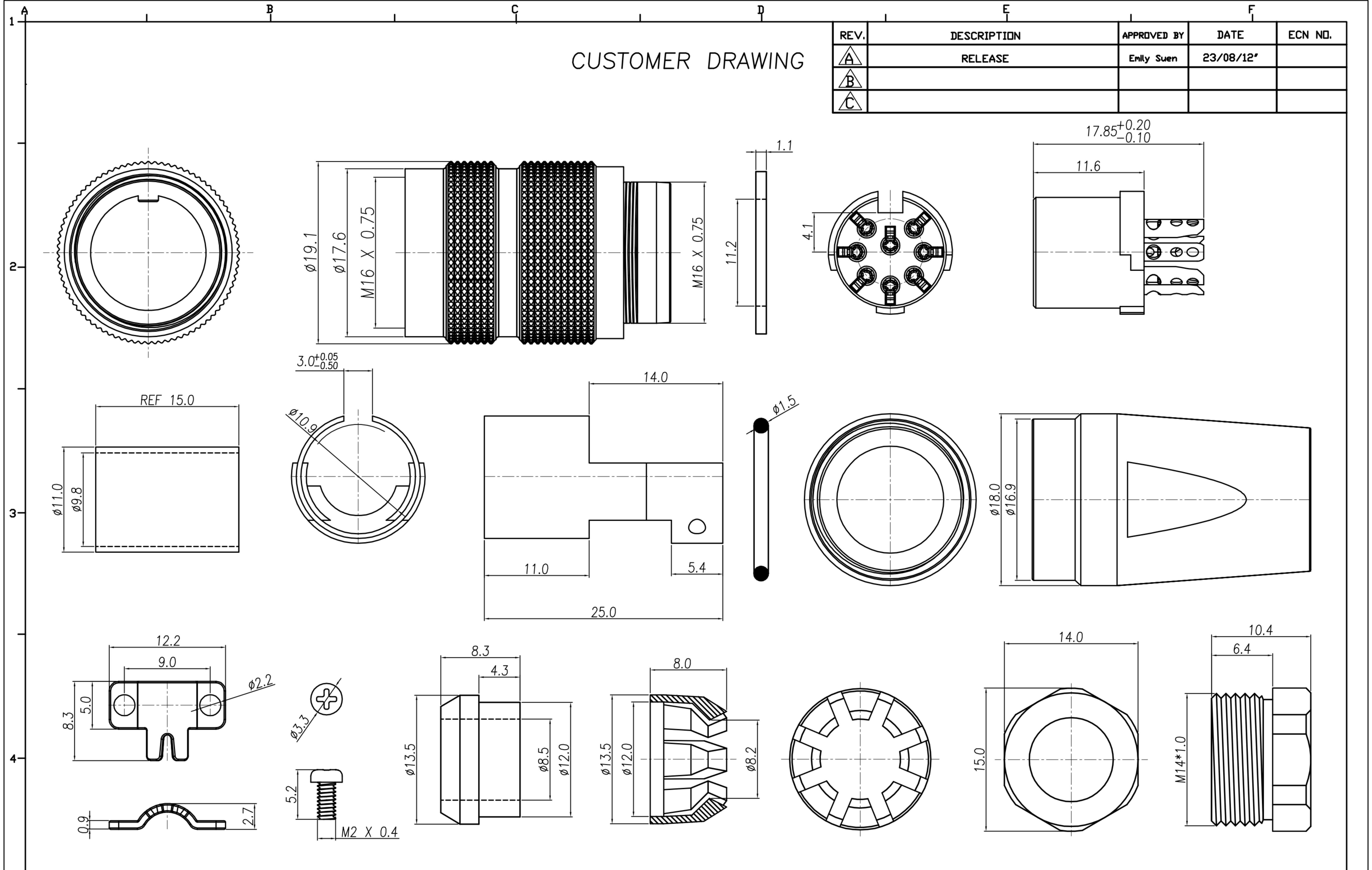

DRAWN	Mark Kao	APP'D	Ku Chou	UNIT	mm	TOLERANCE		广东科斯达电子科技有限公司 GUANG DONG KE SI DA ELECTRONIC TECHNOLOGY CO., LTD.	TITLE	WP DIN (F) Assembly type			SHEET	3
CHK'D	Emily Suen			SCALE	1:1	.x ±0.20 .xx ±0.10 .xxx ±0.05 .xxxx ±0.03 ANGULA ±1°			PART NO.	SEE TABLE A	DWG NO.	QC5932	VERSION	A

CUSTOMER DRAWING

REV.	DESCRIPTION	APPROVED BY	DATE	ECN NO.
△A	RELEASE	Emily Suen	23/08/12'	
△B	額定電流	Ku	26/06/18'	
△C	接線位置	LED	21/01/19'	ECN-19002

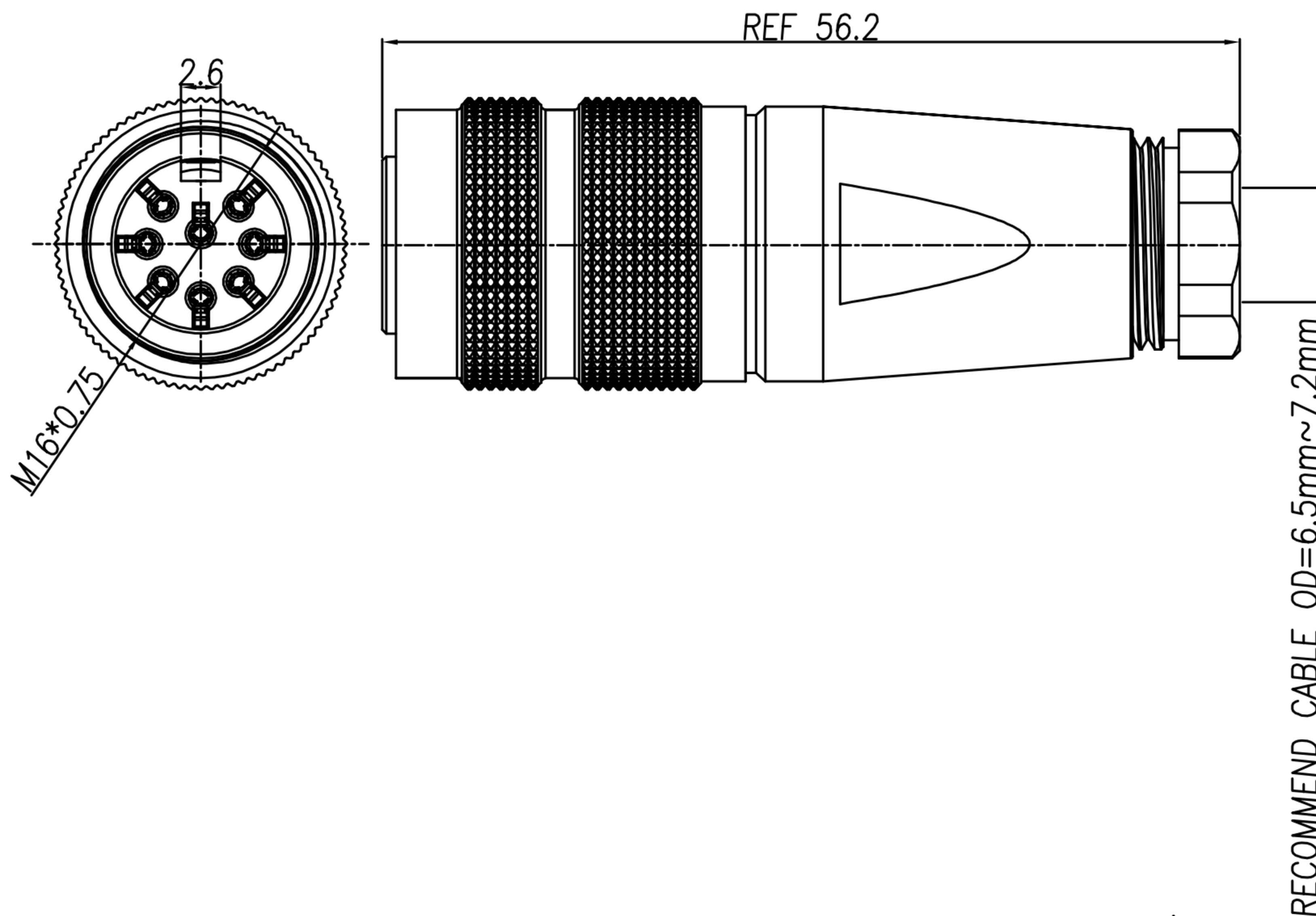

- MATERIAL :
 - 1-1. HOUSING : NYLON UL94V-0 ; COLOR : BLACK
 - 1-2. CONTACT : PHOSPHOR BRONZE
 - 1-3. MAIN BODY : ZINC ALLOY
 - 1-4. LOCK SHELL : BRASS
 - 1-5. SPRING : STAINLESS
 - 1-6. ISOLATION : PVC
 - 1-7. CLAMPS : ZINC ALLOY
 - 1-8. CLAMPS BODY : ZINC ALLOY
 - 1-9. SCREW : SPCC
 - 1-10. BACK BODY : BRASS
 - 1-11. O-RING 1 : SILICONE ; COLOR : RED
 - 1-12. GLAND : SILICONE COLOR : BLACK
 - 1-13. GLAND CAGE : POM ; COLOR : WHITE
 - 1-14. GLAND NUT : ALUMINUM ALLOY
 - 1-15. O-RING 2 : SILICONE ; COLOR : BLACK
- FINISH :
 - 2-1. CONTACT : CONTACT AREA : GOLD FLASH PLATING
SOLDER AREA : TIN
UNDER PLATE : NICKEL
 - 2-2. MAIN BODY : NICKEL PLATED
 - 2-3. LOCK SHELL : NICKEL PLATED
 - 2-4. CLAMPS : NICKEL PLATED
 - 2-5. CLAMPS BODY : NICKEL PLATED
 - 2-6. SCREW : NICKEL PLATED
 - 2-7. BACK BODY : NICKEL PLATED
 - 2-8. GLAND NUT : SATING NICKEL PLATED
- ELECTRICAL SPECIFICATION :
 - △3-1. Rated current : 5A
 - 3-2. Rated Voltage : 250V
 - 3-3. Water proof : IP67
- Environmental :
 - 4-1. Operation Temperature : -20℃~85℃

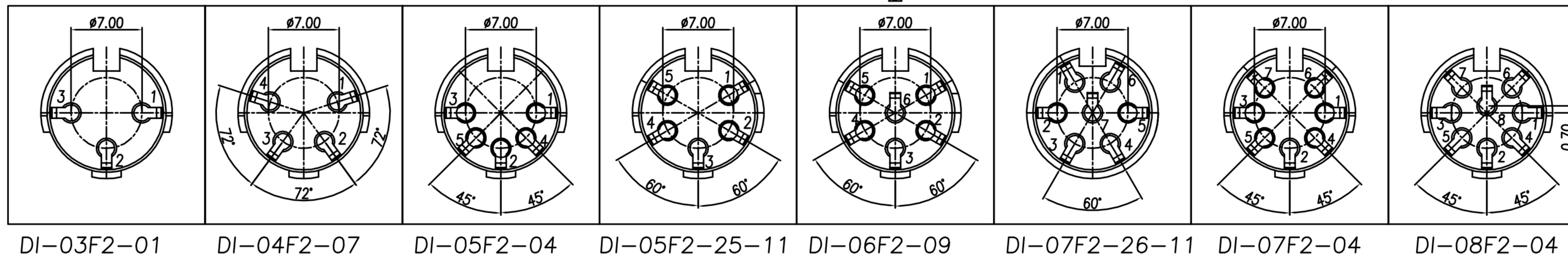

DRAWN	Mark Kao	APP'D	Ku Chou	UNIT	mm	TOLERANCE			广东科斯达电子科技有限公司 GUANG DONG KE SI DA ELECTRONIC TECHNOLOGY CO., LTD.	TITLE	WP M16 DIN (F) Assembly type			SHEET	1/3
CHK'D	Emily Suen			SCALE	1:1	.x ±0.20 .xx ±0.10 .xxx ±0.05 .xxxx ±0.03 ANGULA ±1°				PART NO.	SEE TABLE A	DWG NO.	QC5932	VERSION	C

CUSTOMER DRAWING

REV.	DESCRIPTION	APPROVED BY	DATE	ECN NO.
A	RELEASE	Emily Suen	23/08/12'	
B				
C				

ASSEMBLY INSTRUCTION

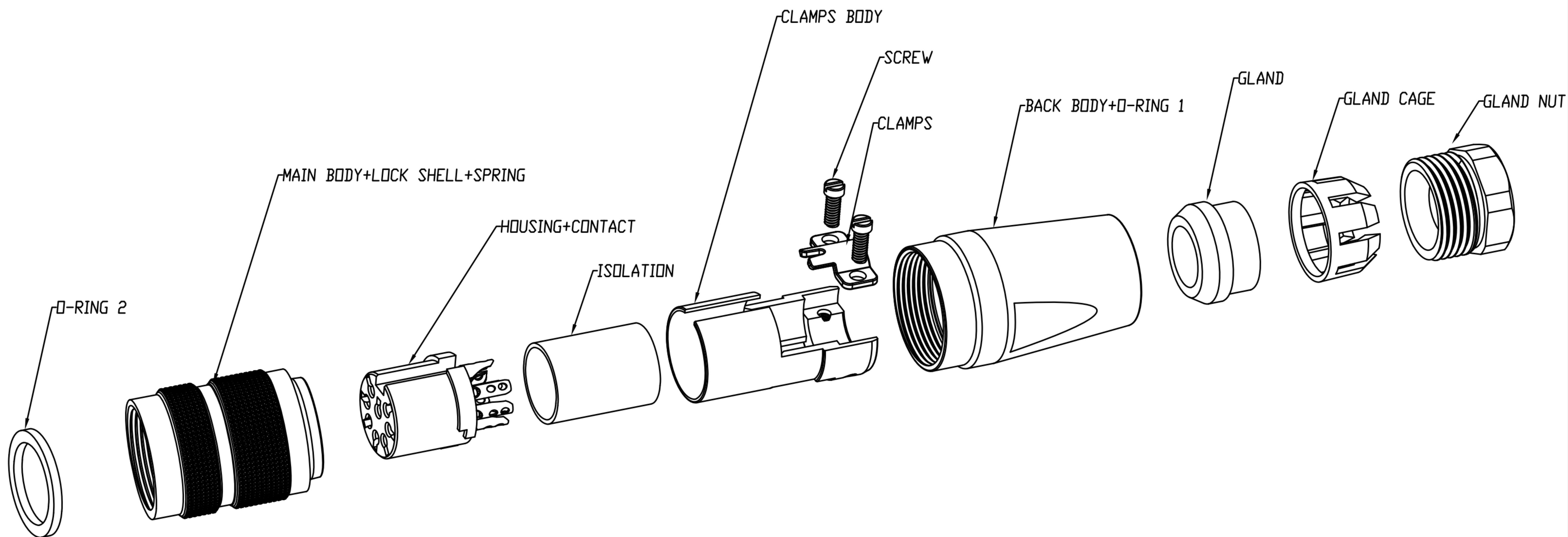

DRAWN	Mark Kao	APP'D	Ku Chou	UNIT	mm	TOLERANCE			TITLE	WP DIN (F) Assembly type			SHEET
CHK'D	Emily Suen			SCALE	1:1	.x ±0.20 .xx ±0.10 .xxx ±0.05 .xxxx ±0.03 ANGULA ±1°			广东科斯达电子科技有限公司 GUANG DONG KE SI DA ELECTRONIC TECHNOLOGY CO., LTD.	PART NO.	SEE TABLE A	DWG NO.	QC5932
									VERSION	A			