

CUSTOMER DRAWING

REV.	DESCRIPTION	APPROVED BY	DATE	ECN NO.
A	RELEASE	Ku Chou	20/07/18'	
B	CHANGE CLAMP RING MATERIAL	Ku Chou	31/10/18'	
C				

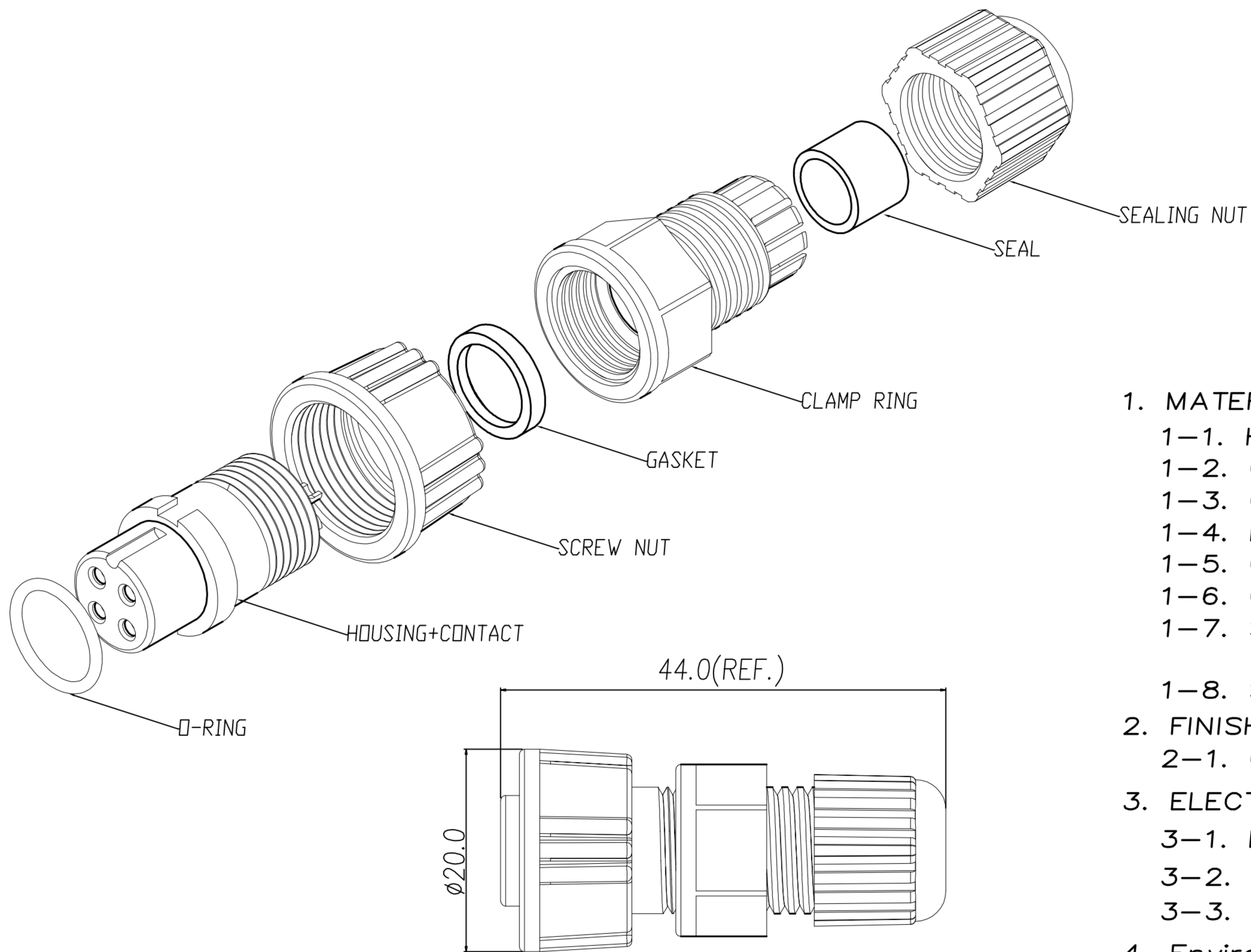

TABLE A

2 PIN	3 PIN	4 PIN
WP-02F2-56-11	WP-03F2-98-11	WP-04F2-196-11

PIN ASSIGNMENTS  
FRONT VIEW

1. MATERIAL :
  - 1-1. HOUSING : PA66
  - 1-2. CONTACT : BRASS
  - 1-3. O-RING : SILICONE
  - 1-4. LOCK NUT : PA66
  - 1-5. GASKET : SILICONE
  - 1-6. CLAMP RING : PA66 B
  - 1-7. SEAL : SILICONE
  - 1-8. SEALING NUT : PA66
2. FINISH :
  - 2-1. CONTACT : GOLD FLASH PLATED.
3. ELECTRICAL SPECIFICATION :
  - 3-1. Rated current : 10A
  - 3-2. Rated voltage : 250V
  - 3-3. Water proof : IP67
4. Environmental :
  - 4-1. Operation Temperature : -40℃~105℃

DRAWN	Emily Suen	APP'D	Ku Chou	UNIT	mm	TOLERANCE		广东科斯达电子科技有限公司 GUANG DONG KE SI DA ELECTRONIC TECHNOLOGY CO., LTD.	TITLE	WP (F) (SCREW) B SIZE ASSEMBLY TYPE(10A)			SHEET	
CHK'D	Ku Chou			SCALE	1:1	.x ±0.20 .xx ±0.10 .xxx ±0.05 .xxxx ±0.03 ANGULA ±1°			PART NO.	SEE TABLE A	DWG NO.	QC8637	VERSION	