

CUSTOMER DRAWING

REV.	DESCRIPTION	APPROVED BY	DATE	ECN NO.
△A	RELEASE	Fido Weng	04/12/14'	
△B				
△C				

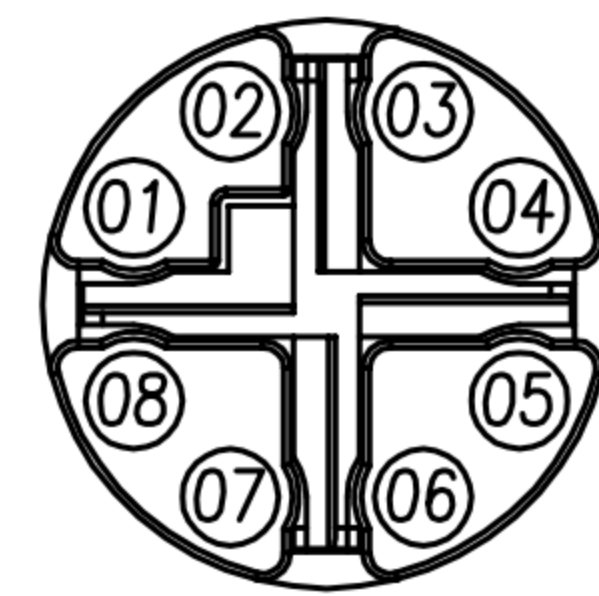
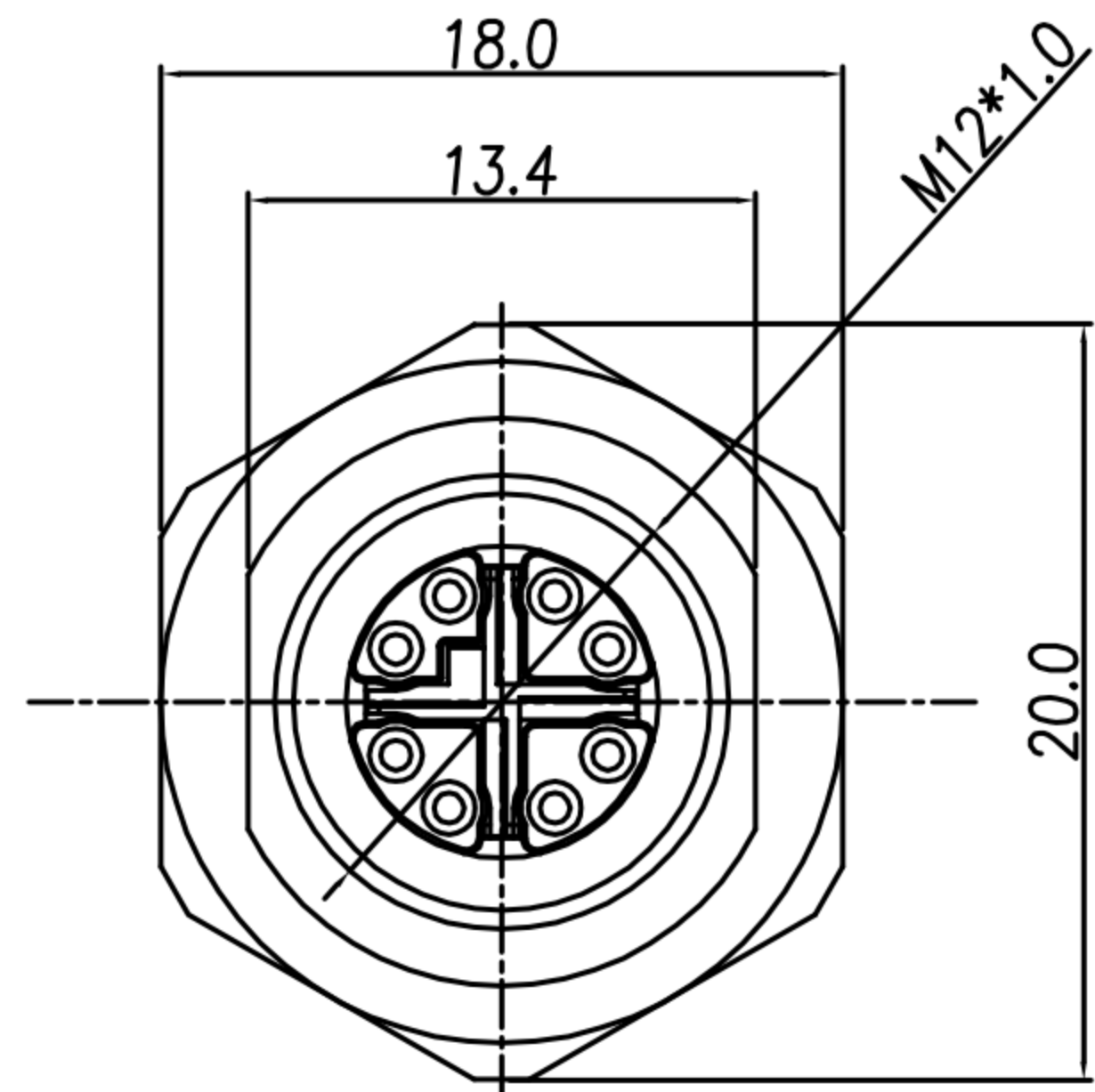
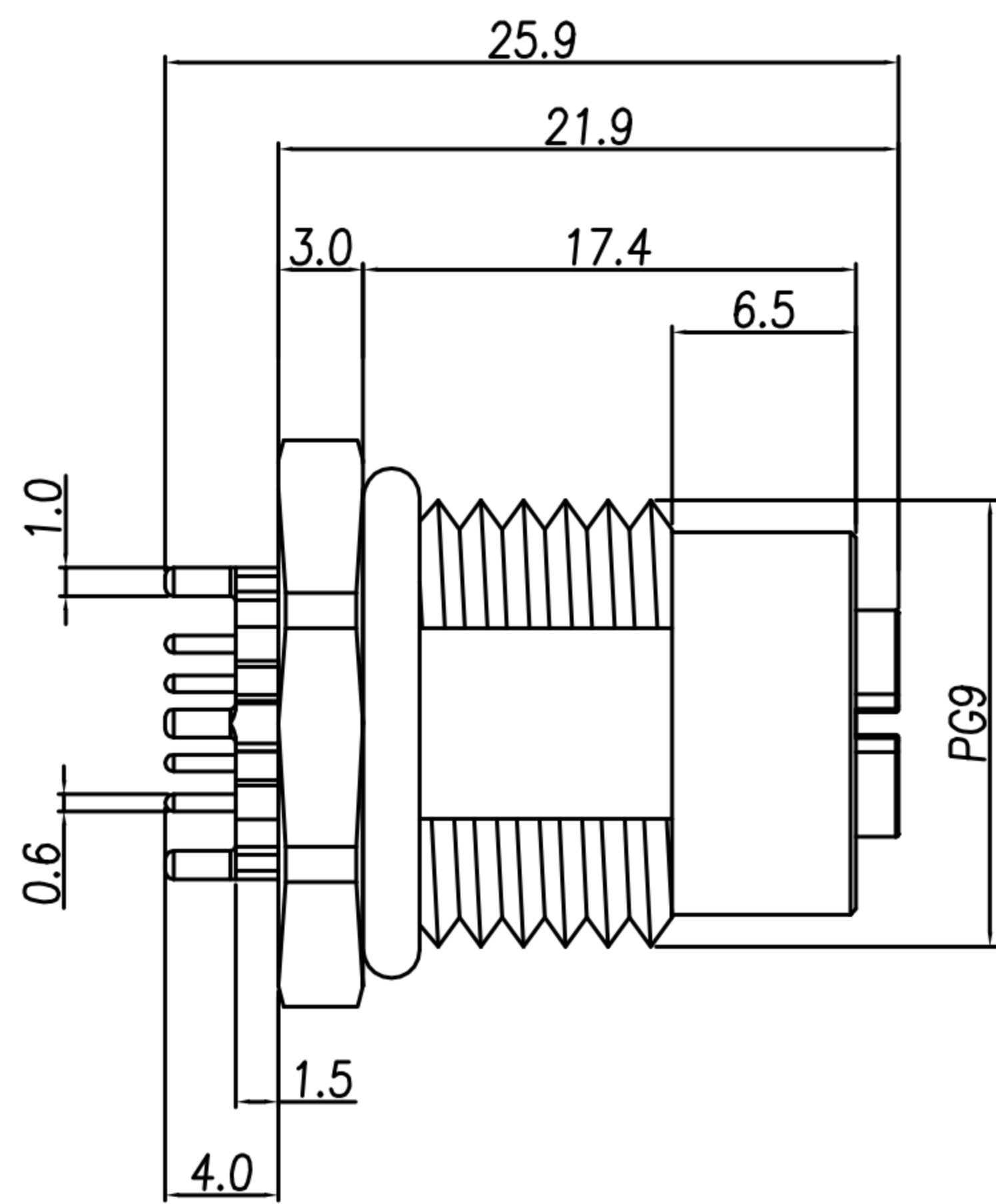

Pin Assignments

TABLE A

KEY	
	WP-08F2-55-11 WP-08F3-13-11 WP-08F3-17-11
	WP-08F3-07-11

PART No.	MATERIAL(SHELL&NUT)	FINISH(SHELL&NUT)	O-RING
WP-08F3-17-11	STAINLESS STEEL 316	-	VITON
WP-08F3-13-11	STAINLESS STEEL 316	-	EPDM
WP-08F3-07-11	BRASS	NICKEL PLATED	EPDM
WP-08F2-55-11	BRASS	NICKEL PLATED	EPDM

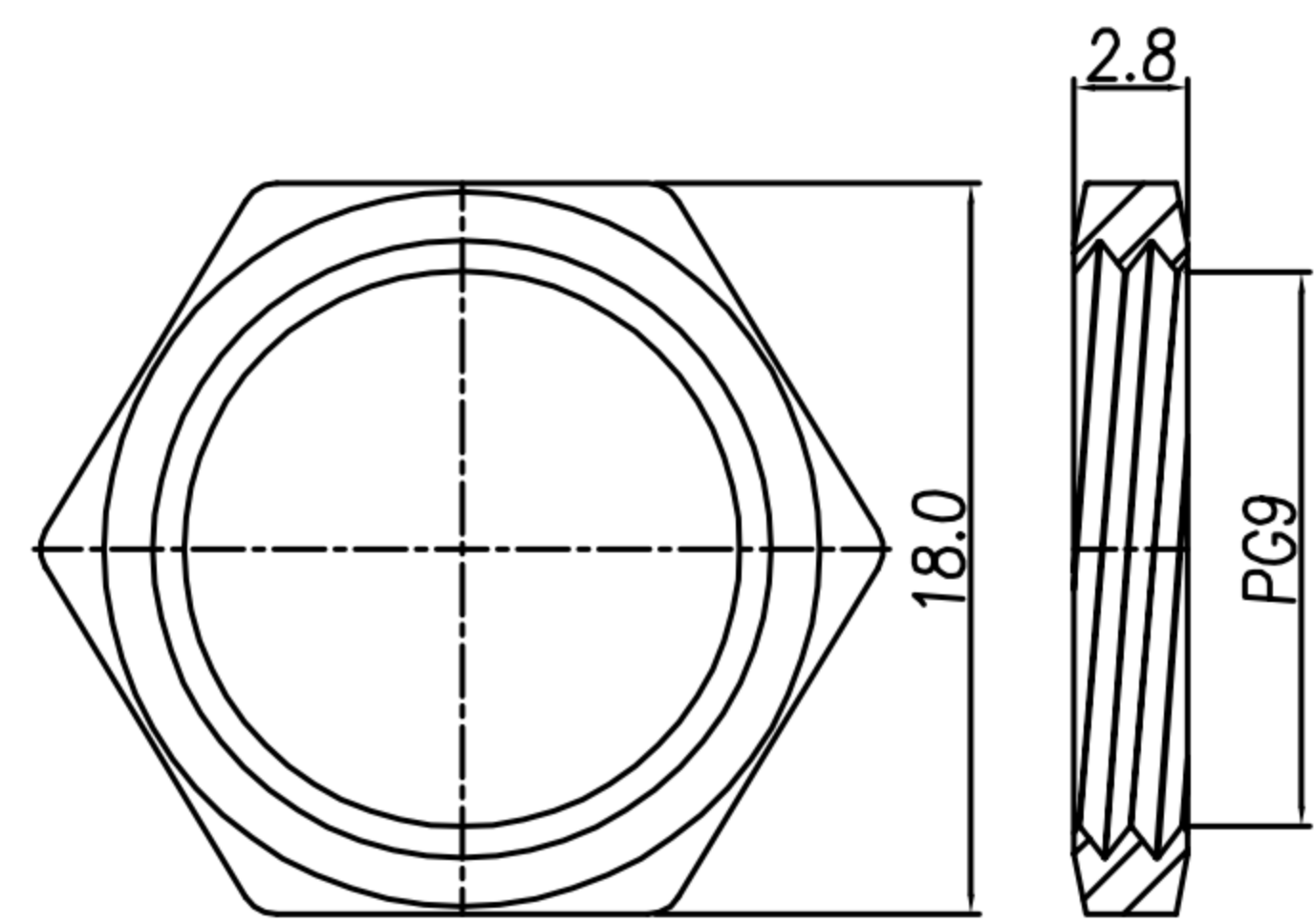

NUT

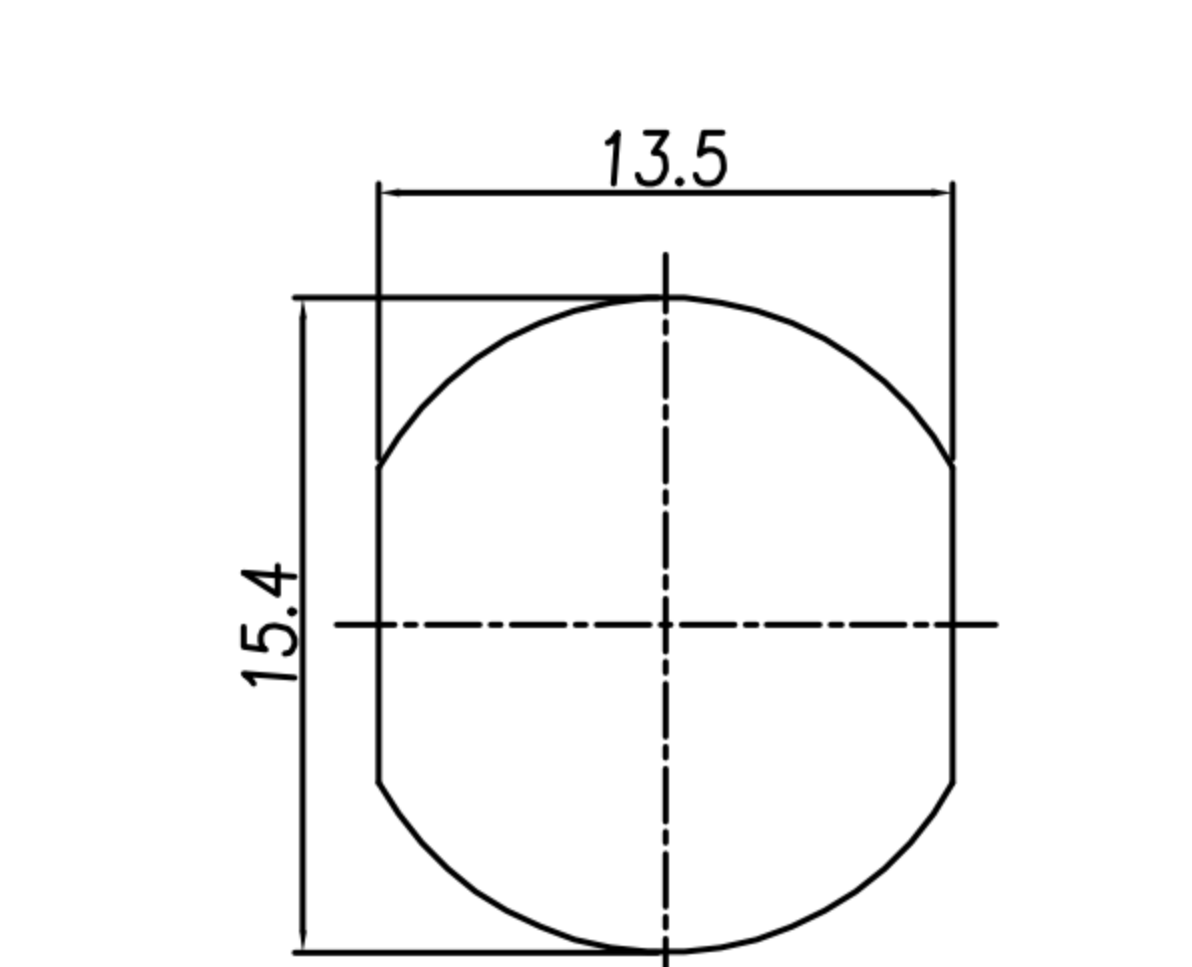

RECOMMEND PANEL CUT-OUT

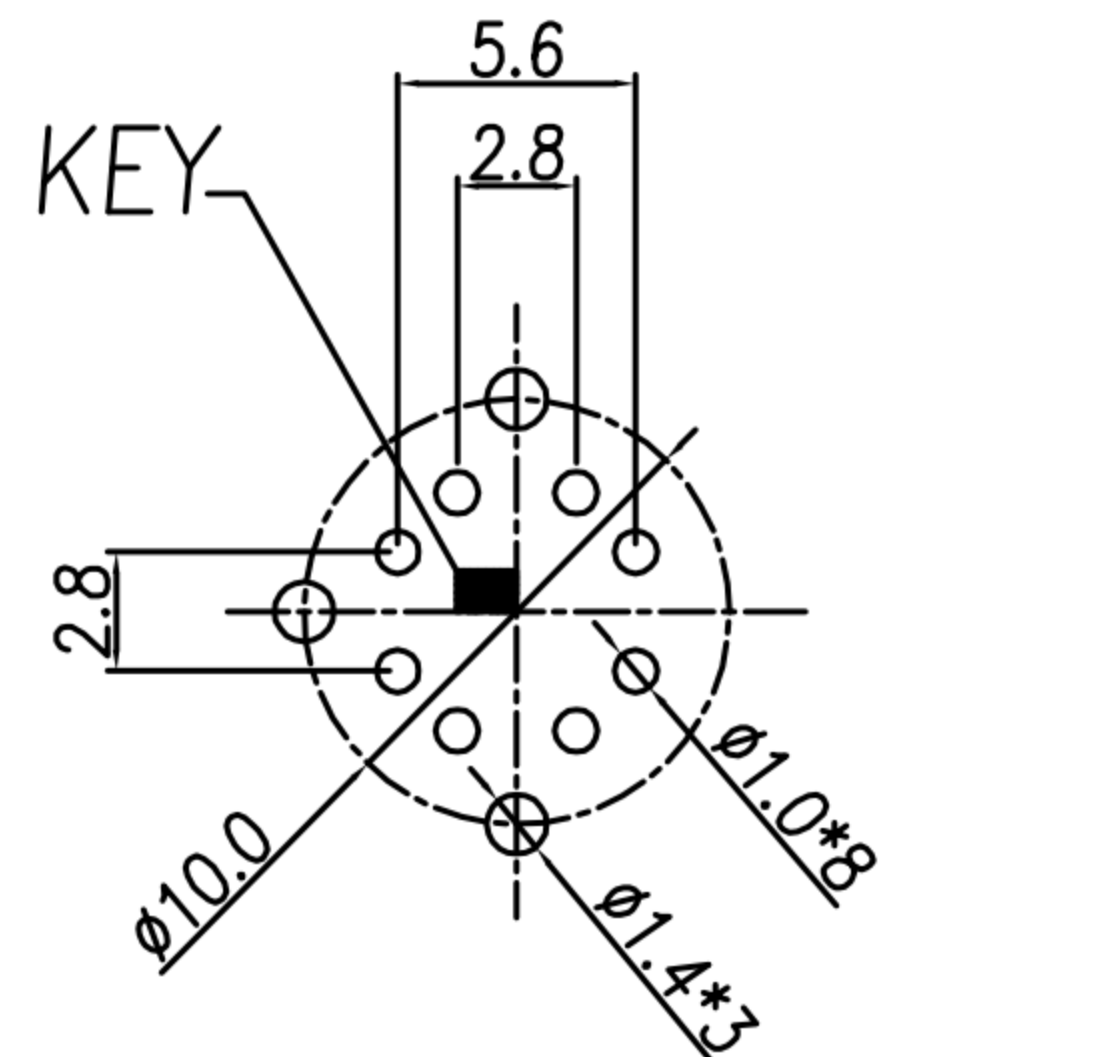

RECOMMEND P.C.B LAYOUT

- MATERIAL :
 - 1-1. HOUSING : PA UL94V-0 ; COLOR : BLACK
 - 1-2. CONTACT : BRASS
 - 1-3. NUT : SEE TABLE A
 - 1-4. SHELL : SEE TABLE A
 - 1-5. O-RING : SEE TABLE A
 - 1-6. X-SHELL : Zn ALLOY
- FINISH :
 - 2-1. CONTACT : 10 MICRO INCHES MIN. GOLD PLATED
UNDER PLATE : NICKEL
 - 2-2. NUT : SEE TABLE A
 - 2-3. SHELL : SEE TABLE A
 - 2-4. X-SHELL : NICKEL PLATED
- ELECTRICAL SPECIFICATION :
 - 3-1. Rated current : 0.5A
 - 3-2. Rated Voltage : 50V AC/60V DC
 - 3-3. Water proof : IP67
- Environmental :
 - 4-1. Operation Temperature : -40℃~85℃

DRAWN	Ku Chou	APPEND	Fido Weng	UNIT	mm	TOLERANCE .x ±0.20 .xx ±0.10 .xxx ±0.05 .xxxx ±0.03 ANGULA ±1°		广东科斯达电子科技有限公司 GUANG DONG KE SI DA ELECTRONIC TECHNOLOGY CO., LTD.	TITLE	防水頭 M12 8PIN X-Code (F) 前脚Pg9 DIP式(無溝槽)			SHEET	1/2
CHKD	Emily Suen			SCALE	1:1				PART NO.	SEE TABLE A	DWG NO.	QC7053	VERSION	A