

CUSTOMER DRAWING

REV.	DESCRIPTION	APPROVED BY	DATE	ECN NO.
B	修改RATED CURRENT	Ku	26/06/18"	
C	新增機殼	LEO	20/07/18"	
D	新增機殼	LEO	26/02/19"	
E	新增機殼	Yeh	20/08/21"	

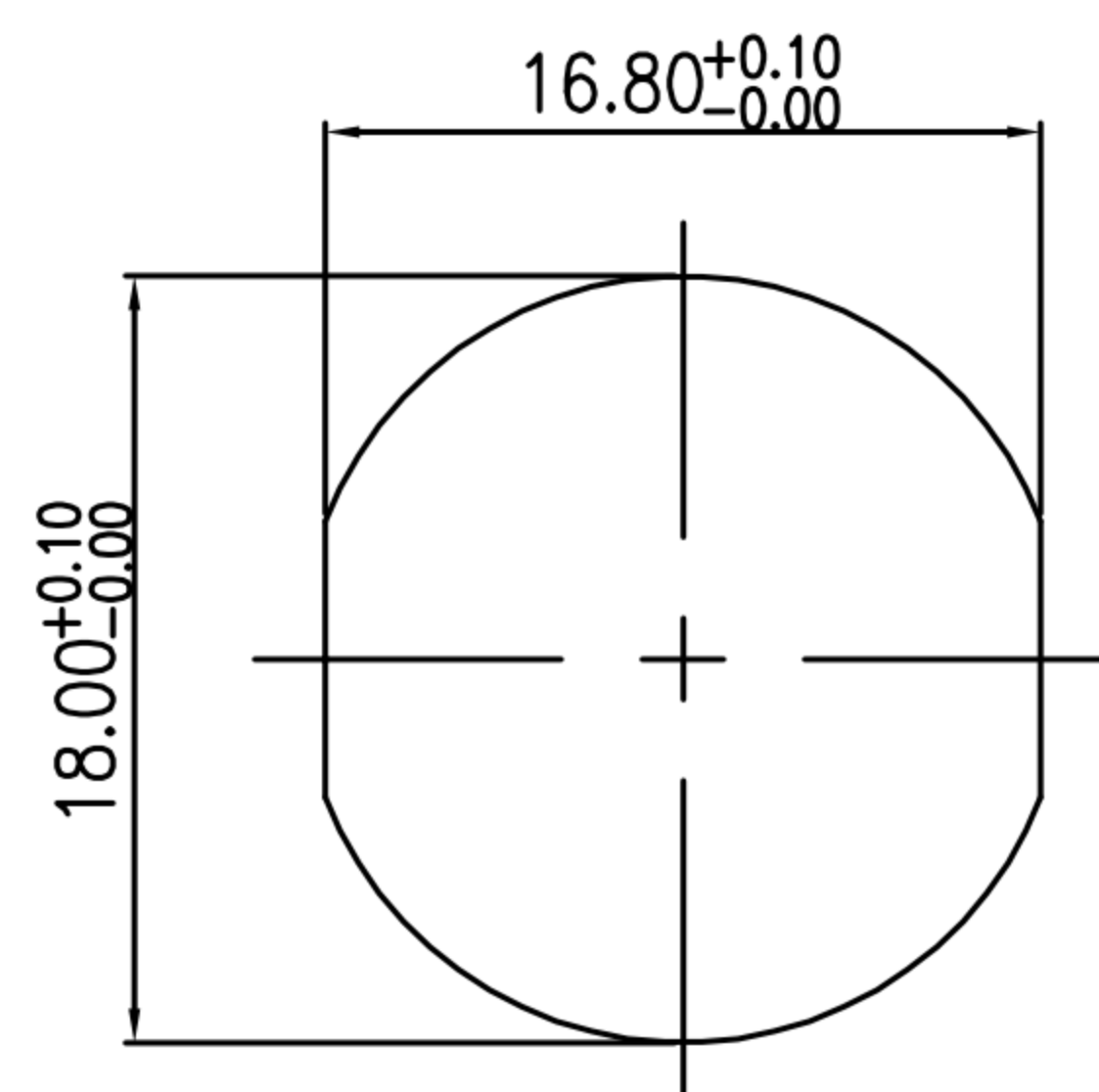

RECOMMEND PANEL CUT-OUT

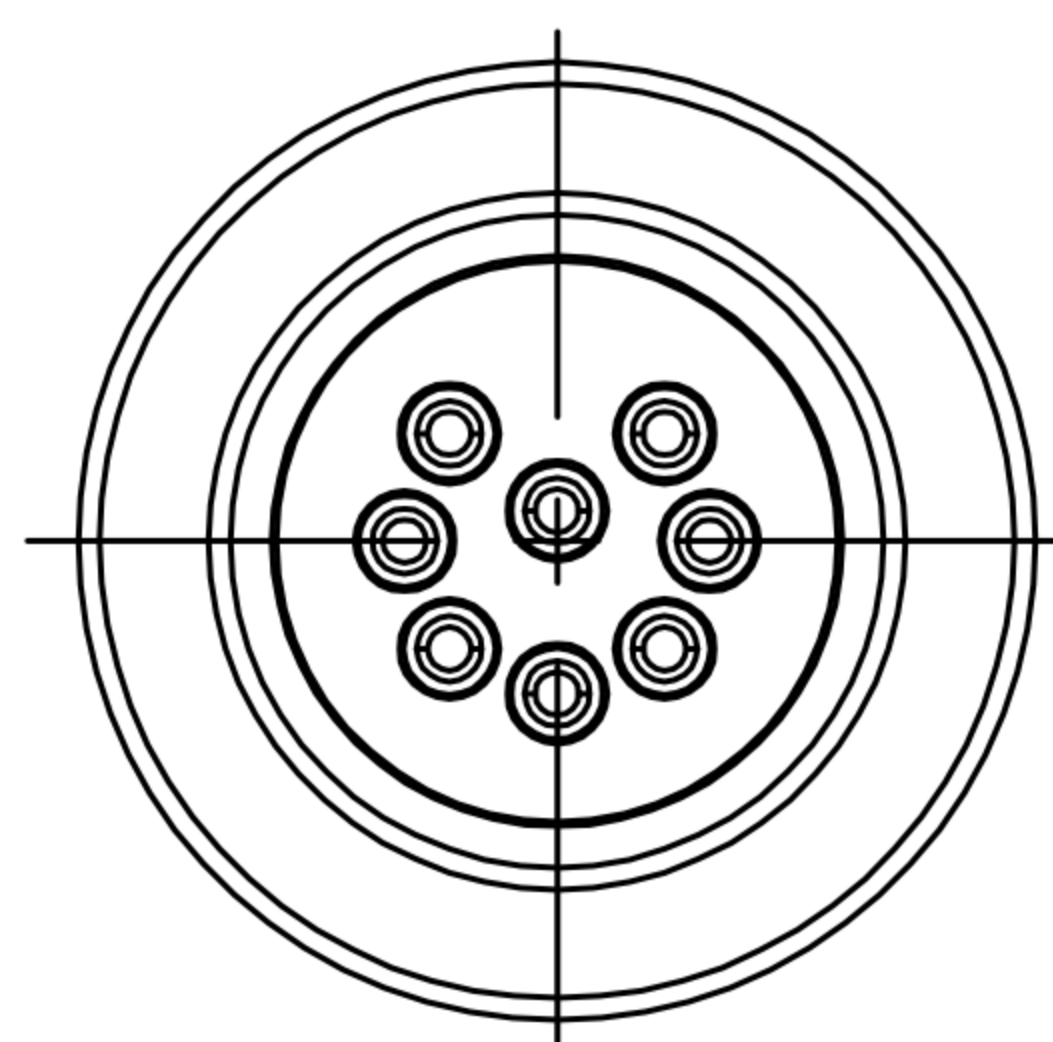
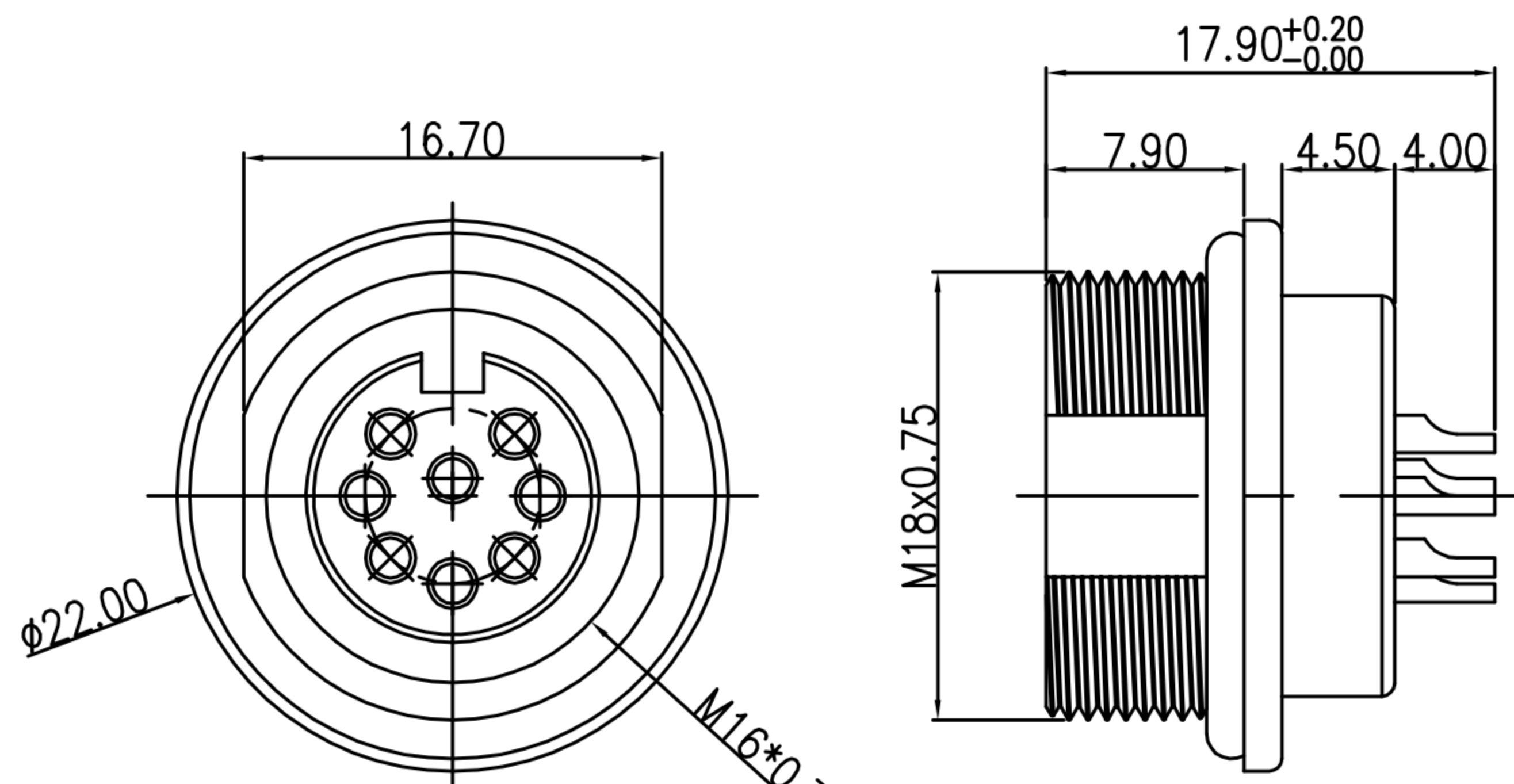
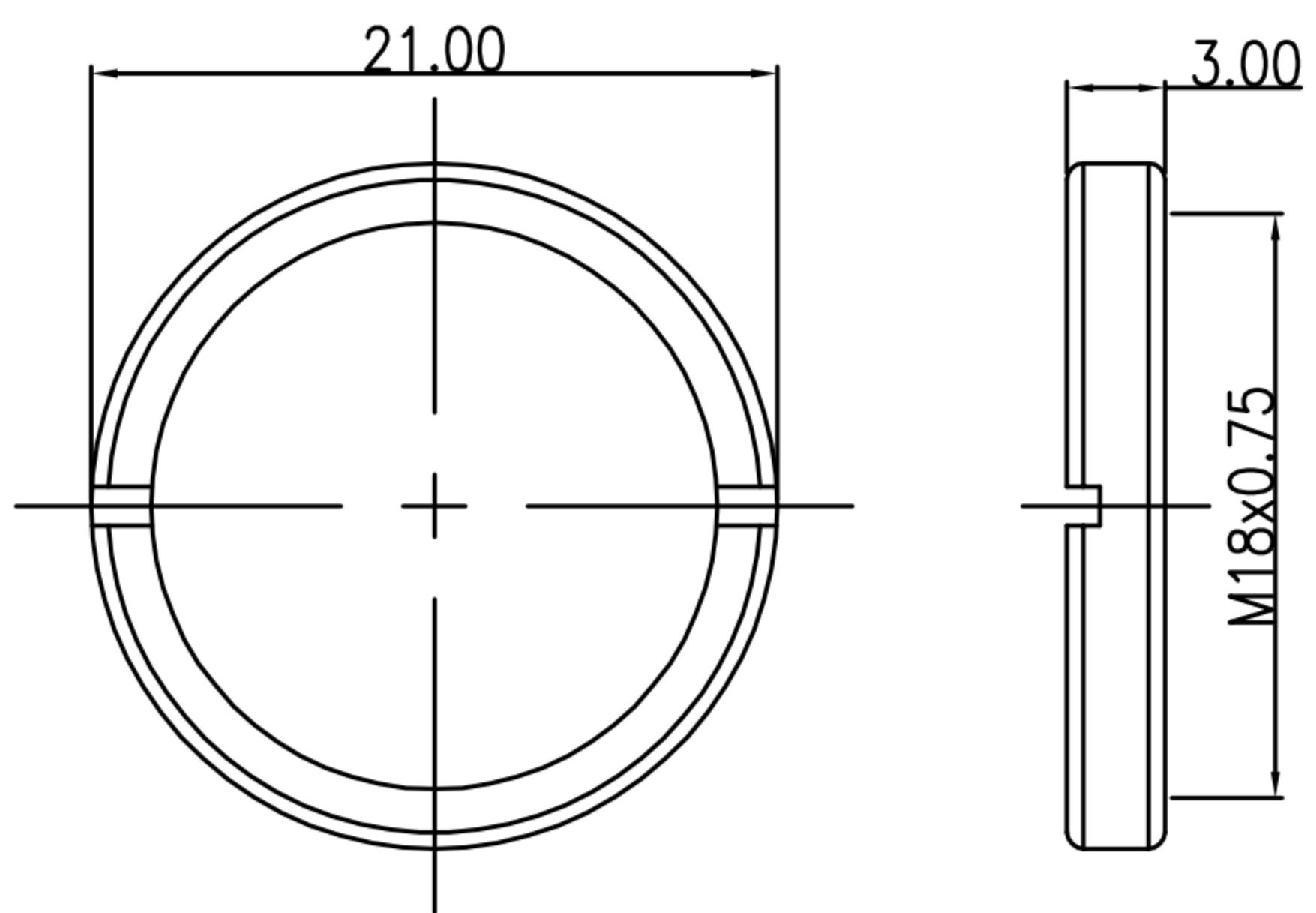

NUT

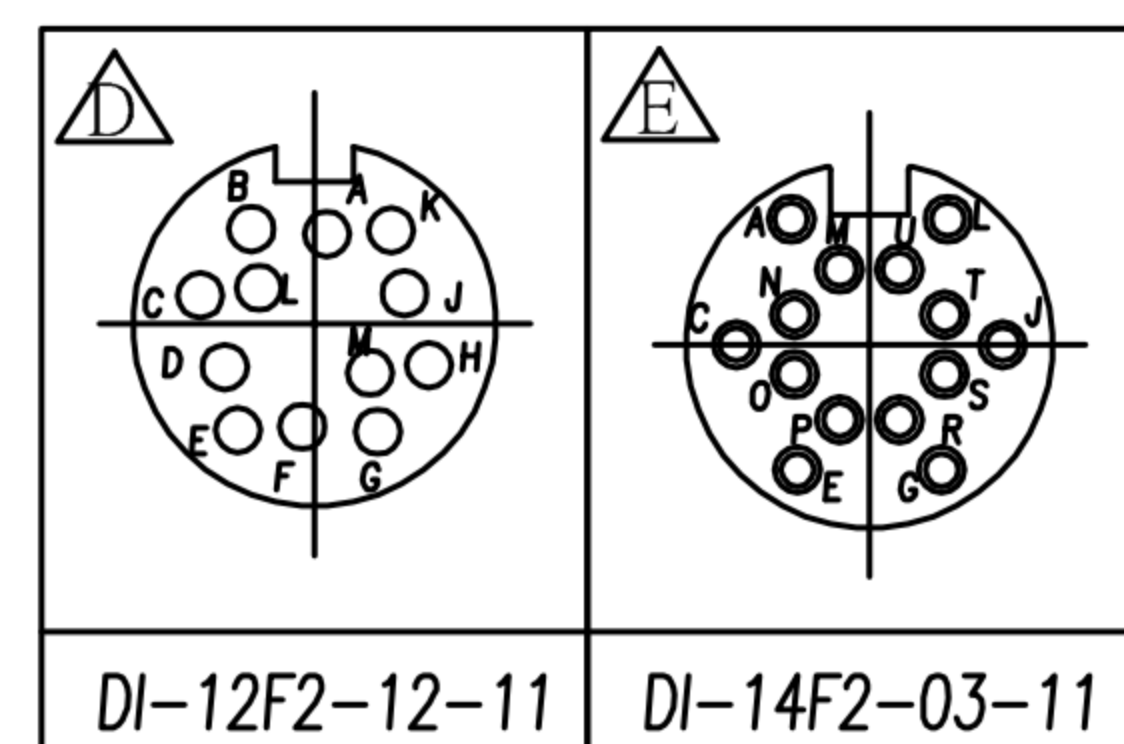

DI-12F2-12-11 DI-14F2-03-11

DI-03F2-07-11	DI-04F2-15-11	DI-05F2-26-11	DI-05F2-10-11	DI-06F2-17-11	DI-07F2-13-11	DI-07F2-09-11	DI-08F2-09-11

- MATERIAL :
 - 1-1. HOUSING : PA66 ; COLOR : BLACK.
 - 1-2. CONTACT : BRASS
 - 1-3. NUT : BRASS
 - 1-4. O-RING : EPDM ; COLOR : BLACK
 - 1-5. SHELL : BRASS.
- FINISH :
 - 2-1. CONTACT : GOLD FLASH MICRO INCHES MIN.
UNDER PLATE : NICKEL
 - 2-2. NUT : NICKEL PLATED
 - 2-3. SHELL : NICKEL PLATED
- ELECTRICAL SPECIFICATION :
 - 3-1. Rated current : 3PIN~8PIN 5A ; 12~14PIN 3A
 - 3-2. Rated Voltage : 3PIN~8PIN 250V ; 12~14PIN 60V
 - 3-3. Water proof: IP68
- Environmental :
 - 4-1. Operation Temperature : -40℃~85℃

DRAWN	Mark Kao	APP'D	Ku Chou	UNIT	mm	TOLERANCE			广东科斯达电子科技有限公司 GUANG DONG KE SI DA ELECTRONIC TECHNOLOGY CO., LTD.	TITLE	DIN 270° (F) 前鎖焊線式			SHEET	
CHK'D	Emily Suen			SCALE	1:1	.x ±0.20 .xx ±0.10 .xxx ±0.05 .xxxx ±0.03 ANGULA ±1°				PART NO.	SEE TABLE A	DWG.NO.	QC7457	VERSION	