

CUSTOMER DRAWING

REV.	DESCRIPTION	APPROVED BY	DATE	ECN NO.
A	RELEASE	Fido Weng	12/03/10*	
B				
C				

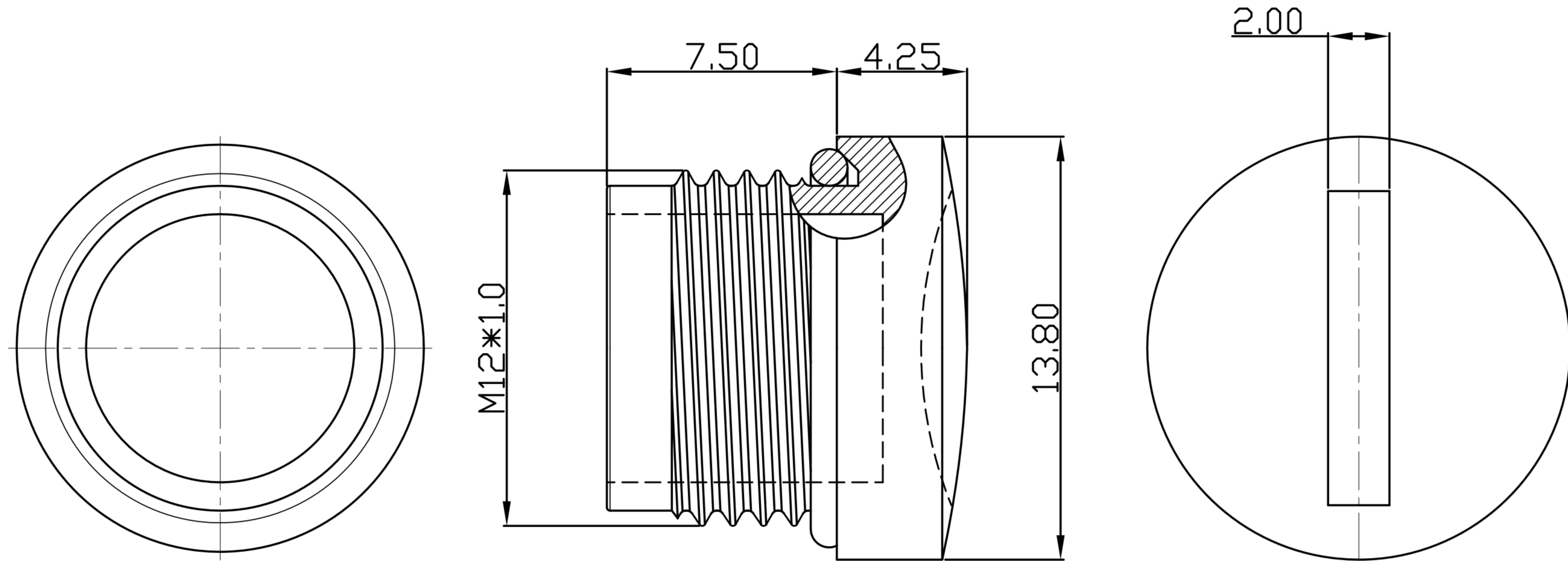

- NOTE :
1. MATERIAL : BRASS
 2. O-RING : NBR
 3. FINISH : NICKEL 100u"

DRAWN	Ku Chou	APP'D	Emily Suen	UNIT	mm	TOLERANCE			TITLE	WP M12 COVER(銅)(油封槽)+O-ring			SHEET	1
CHK'D	Emily Suen			SCALE	1:1	.x ±0.20 .xx ±0.15 .xxx ±0.10 .xxxx ±0.05 ANGULA ±1°			PART NO.	NY-WP368	DWG NO.	QC5374	VERSION	A