

CUSTOMER DRAWING

TABLE A

P/N	MATERIAL(CLAMP RING)
WP-02F2-55-11	PA66
WP-03F2-97-11	PA66
WP-04F2-195-11	PA66
WP-05F2-151-11	PA66
WP-06F2-63-11	PA66
WP-07F2-11-11	PA66
WP-08F2-102-11	PA66
WP-08F2-106-11	PBT+PC, UL94V-0(F1)

REV.	DESCRIPTION	APPROVED BY	DATE	ECN NO.
	RELEASE	Ku Chou	20/07/18*	
	CHANGE CLAMP RING MATERIAL	Ku Chou	31/10/18*	
	ADD P/N	Ku Chou	11/12/18*	

TABLE A

6 PIN	7 PIN	WP-08F2-102-11	
WP-06F2-63-11	WP-07F2-11-11	WP-08F2-106-11	
2 PIN	3 PIN	4 PIN	5 PIN
WP-02F2-55-11	WP-03F2-97-11	WP-04F2-195-11	WP-05F2-151-11

PIN ASSIGNMENTS FRONT VIEW

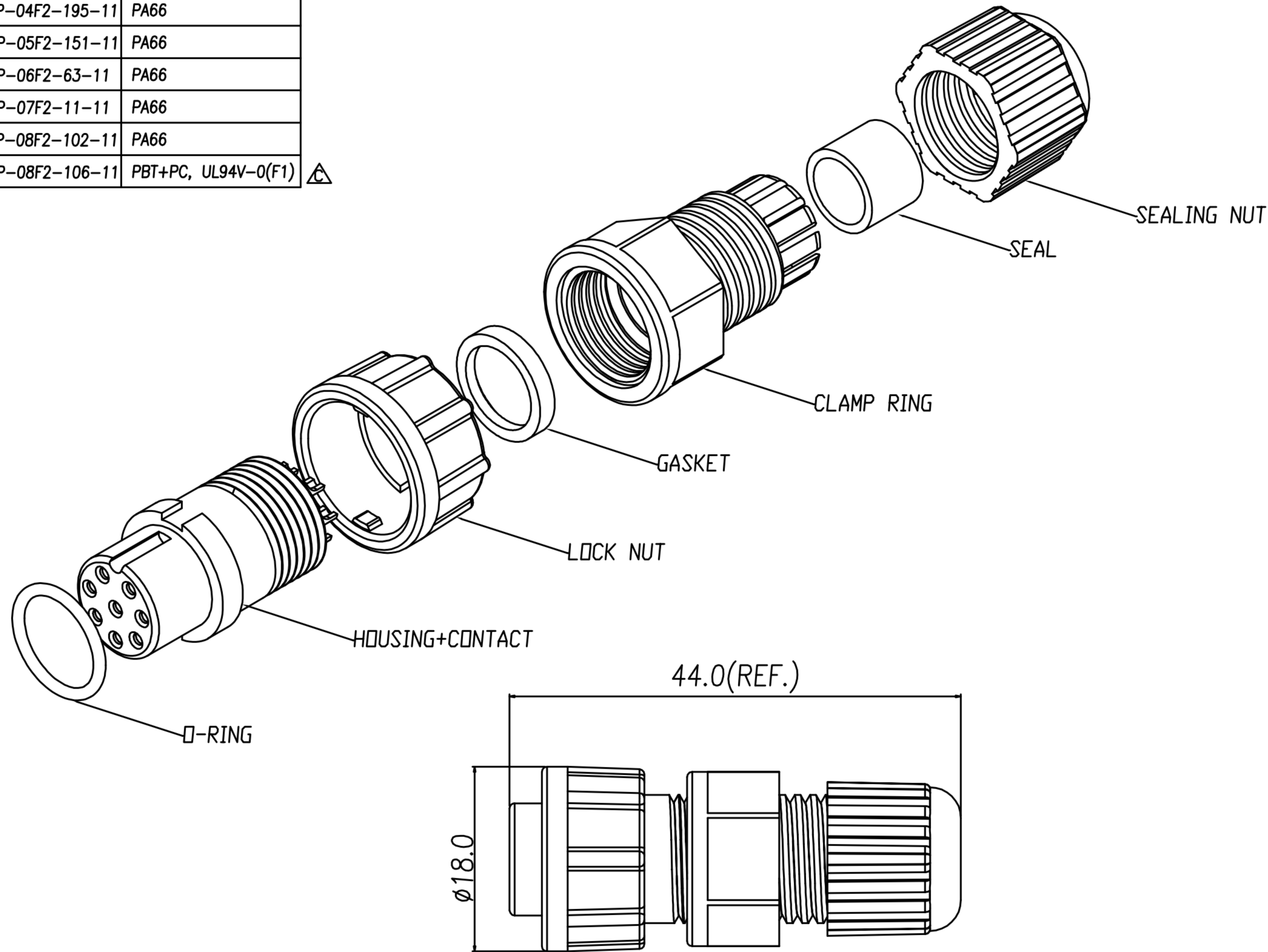

- MATERIAL :
  - 1-1. HOUSING : PA66
  - 1-2. CONTACT : BRASS
  - 1-3. O-RING : SILICONE
  - 1-4. LOCK NUT : PA66
  - 1-5. GASKET : SILICONE
  - 1-6. CLAMP RING : SEE TABLE A
  - 1-7. SEAL : SILICONE
  - 1-8. SEALING NUT : PA66
- FINISH :
  - 2-1. CONTACT : GOLD FLASH PLATED.
- ELECTRICAL SPECIFICATION :
  - 3-1. Rated current : 5A
  - 3-2. Rated voltage : 250V
  - 3-3. Water proof : IP67
- Environmental :
  - 4-1. Operation Temperature : -40°C~105°C

DRAWN	Emily Suen	APP'D	Ku Chou	UNIT	mm	TOLERANCE		广东科斯达电子科技有限公司 GUANG DONG KE SI DA ELECTRONIC TECHNOLOGY CO., LTD.	TITLE	WP (F) (LOCK) B SIZE ASSEMBLY TYPE(5A)			SHEET	1
CHK'D	Ku Chou			SCALE	1:1	.x ±0.20 .xx ±0.10 .xxx ±0.05 .xxxx ±0.03 ANGULA ±1°			PART NO.	SEE TABLE A	DWG NO.	QC8635	VERSION	