

CUSTOMER DRAWING

REV.	DESCRIPTION	APPROVED BY	DATE	ECN NO.
A	RELEASE	Ku Chou	10/03/20'	
B				
C				

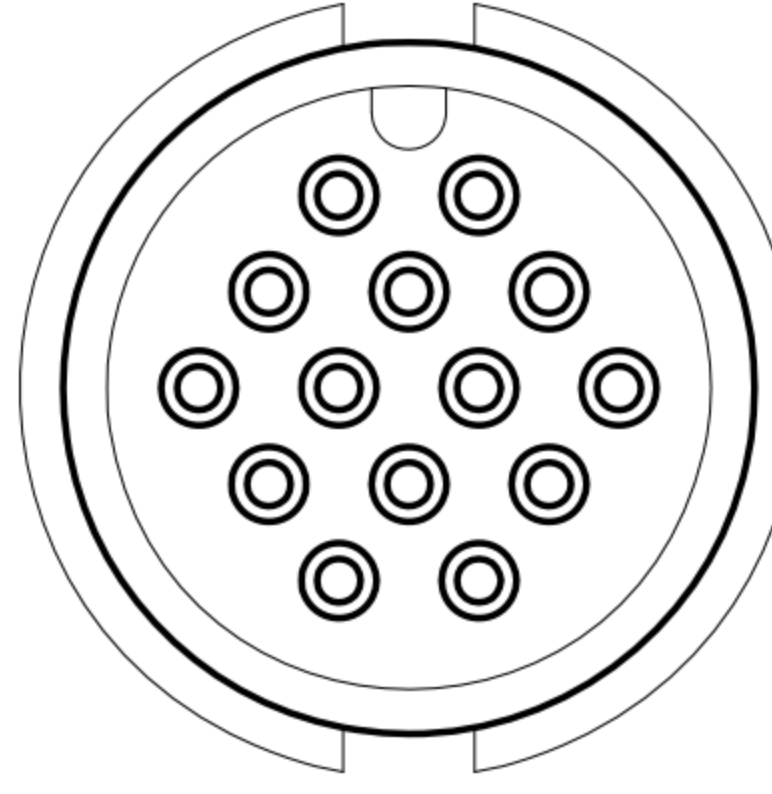
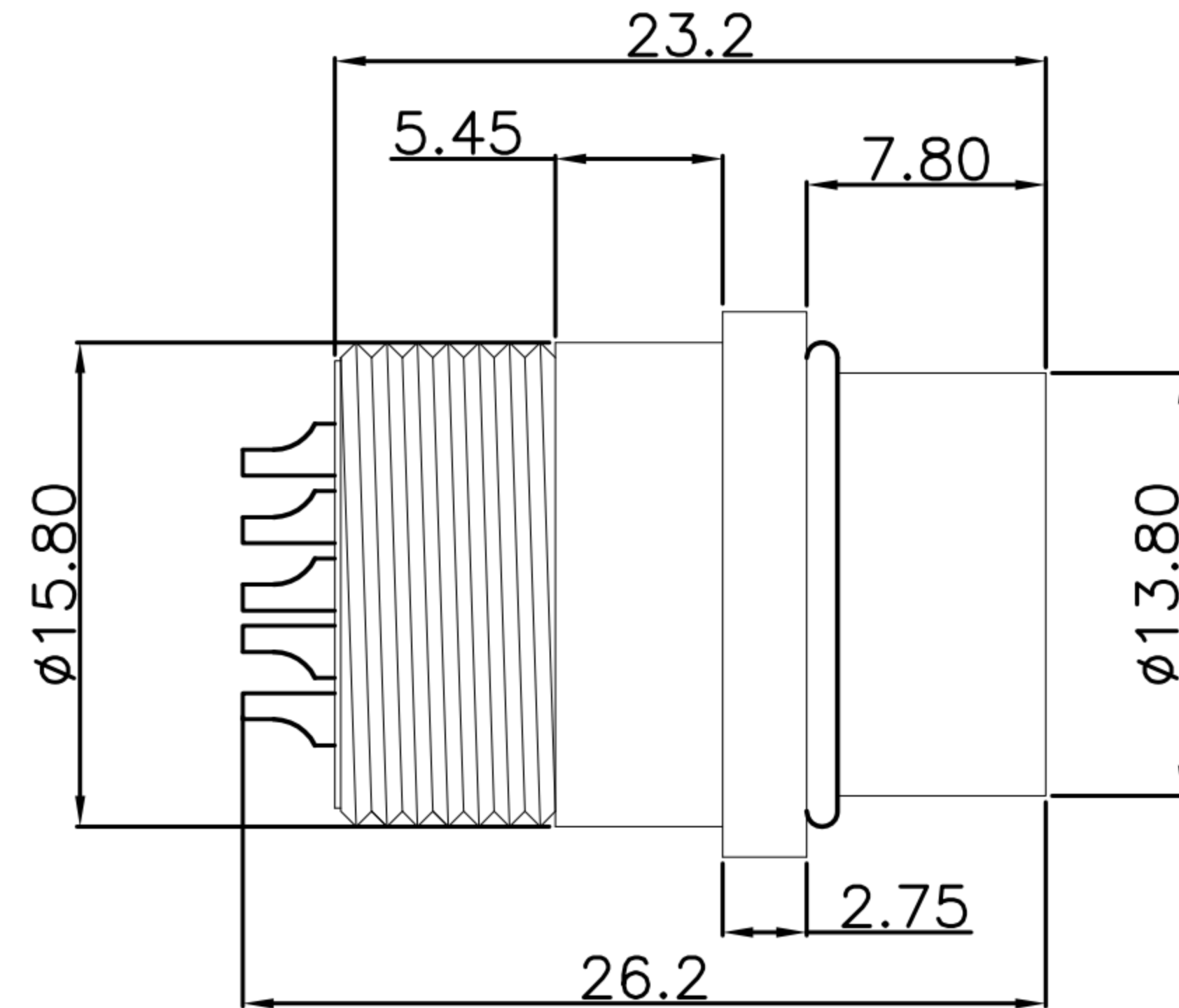
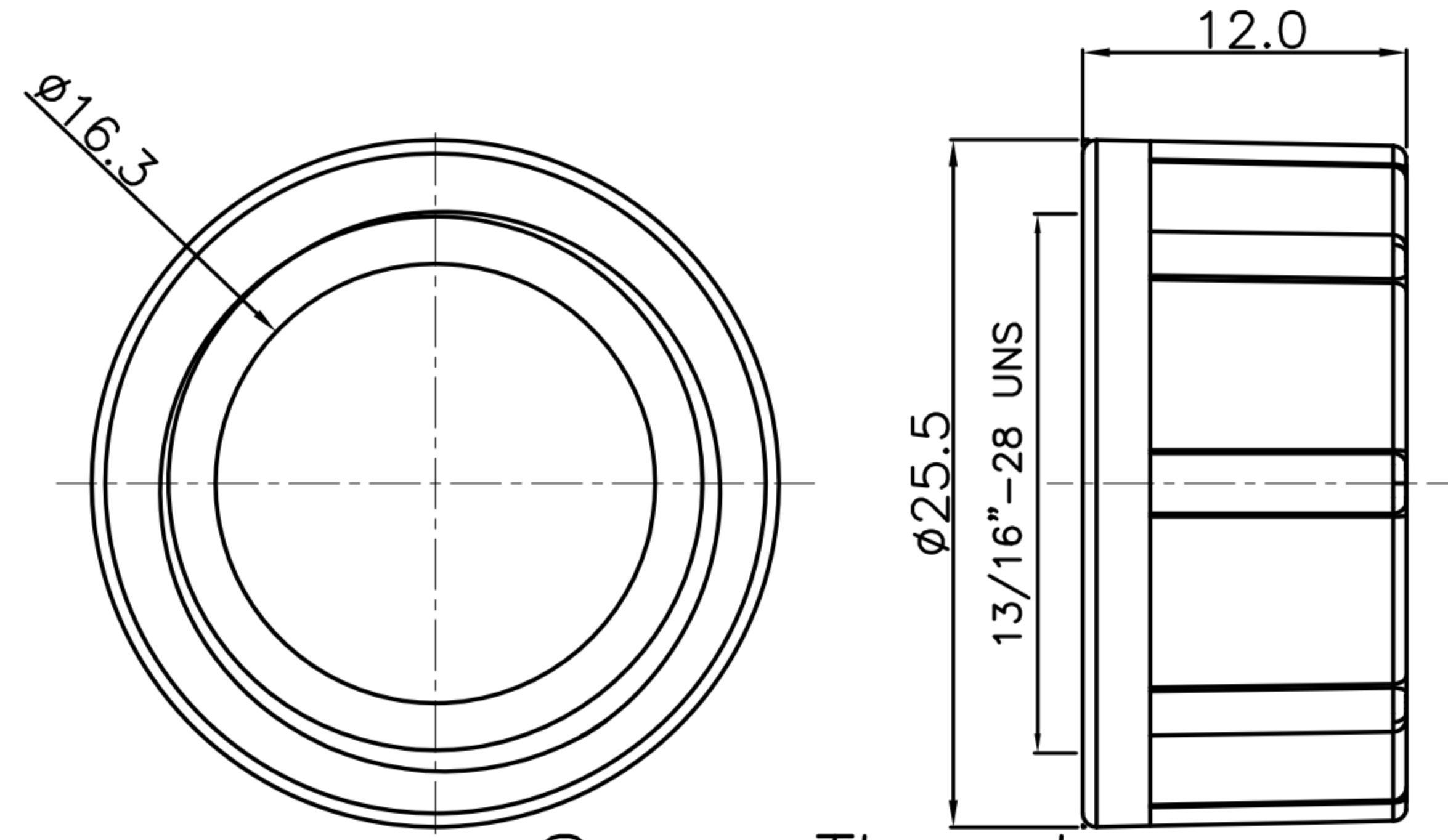
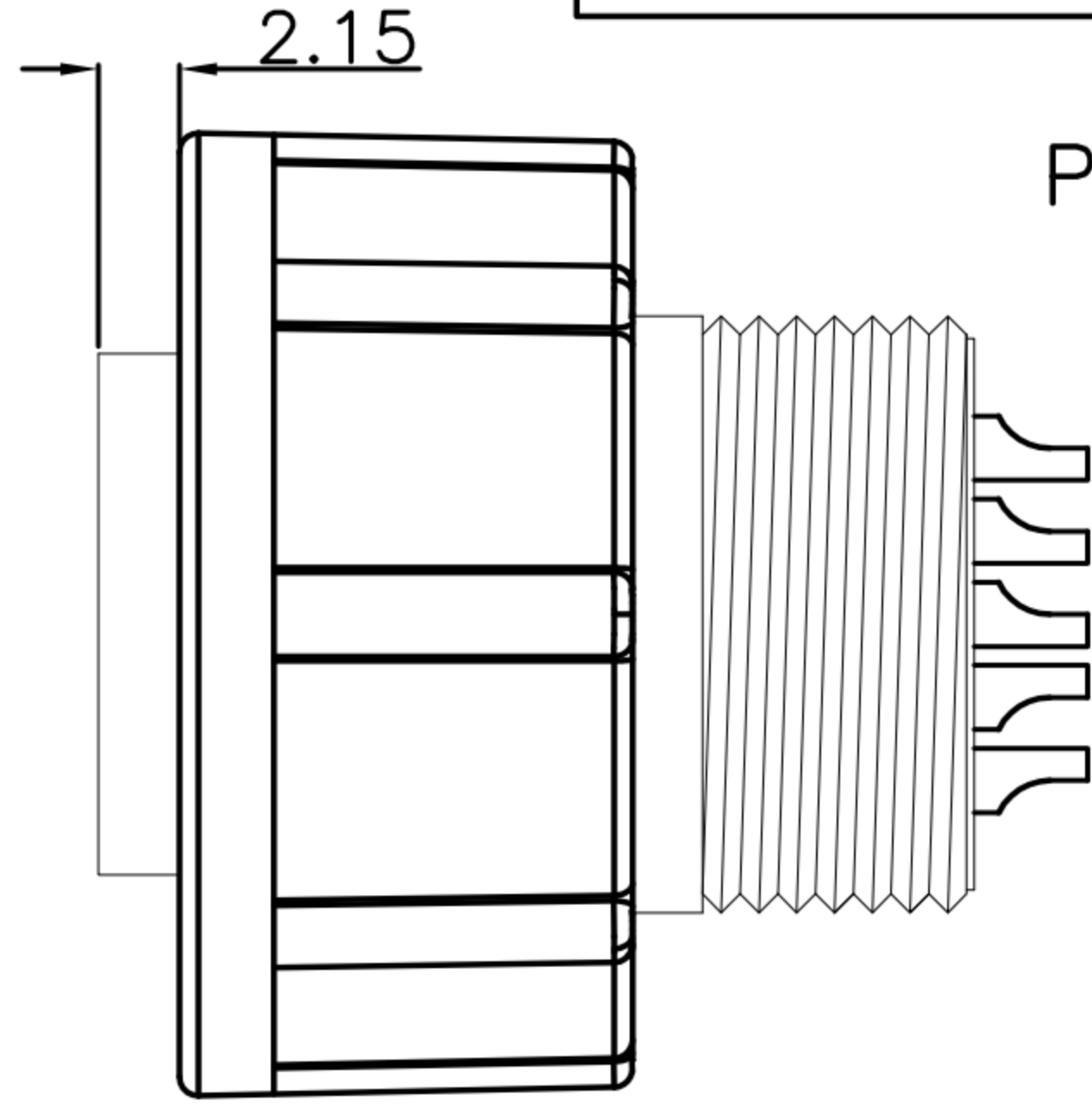

TABLE A

<p>07 PIN WP-07F1-02-11</p>	<p>08 PIN WP-08F1-02-11</p>	<p>09 PIN WP-09F1-02-11</p>
<p>10 PIN Coming soon</p>	<p>12 PIN Coming soon</p>	<p>14 PIN WP-14F1-02-11</p>



Screw Thread



Assembly

PIN ASSIGNMENTS/FRONT VIEW

- MATERIAL :
  - 1-1. HOUSING : PA66
  - 1-2. CONTACT : BRASS
  - 1-3. O-RING : SILICONE
  - 1-4. HEX NUT : PA66
- FINISH :
  - 2-1. CONTACT : GOLD FLASH PLATED.
- ELECTRICAL SPECIFICATION :
  - 3-1. Rated current : 5A
  - 3-2. Rated Voltage : 250V
  - 3-3. Water proof : IP67
- Environmental :
  - 4-1. Operation Temperature : -20℃~80℃

DRAWN	Emily Suen	APP'D	Ku Chou	UNIT	mm	TOLERANCE			TITLE	WP C Size(F) Molded with Cabl(Screw Thread)			SHEET	
CHK'D	Ku Chou			SCALE	1:1	.x ±0.20 .xx ±0.10 .xxx ±0.05 .xxxx ±0.03 ANGULA ±1°			PART NO.	SEE TABLE A	DWG NO.	QC10218	VERSION	