

CUSTOMER DRAWING

REV.	DESCRIPTION	APPROVED BY	DATE	ECN NO.
A	RELEASE	Ku Chou	31/07/18'	
B				
C				

TABLE A

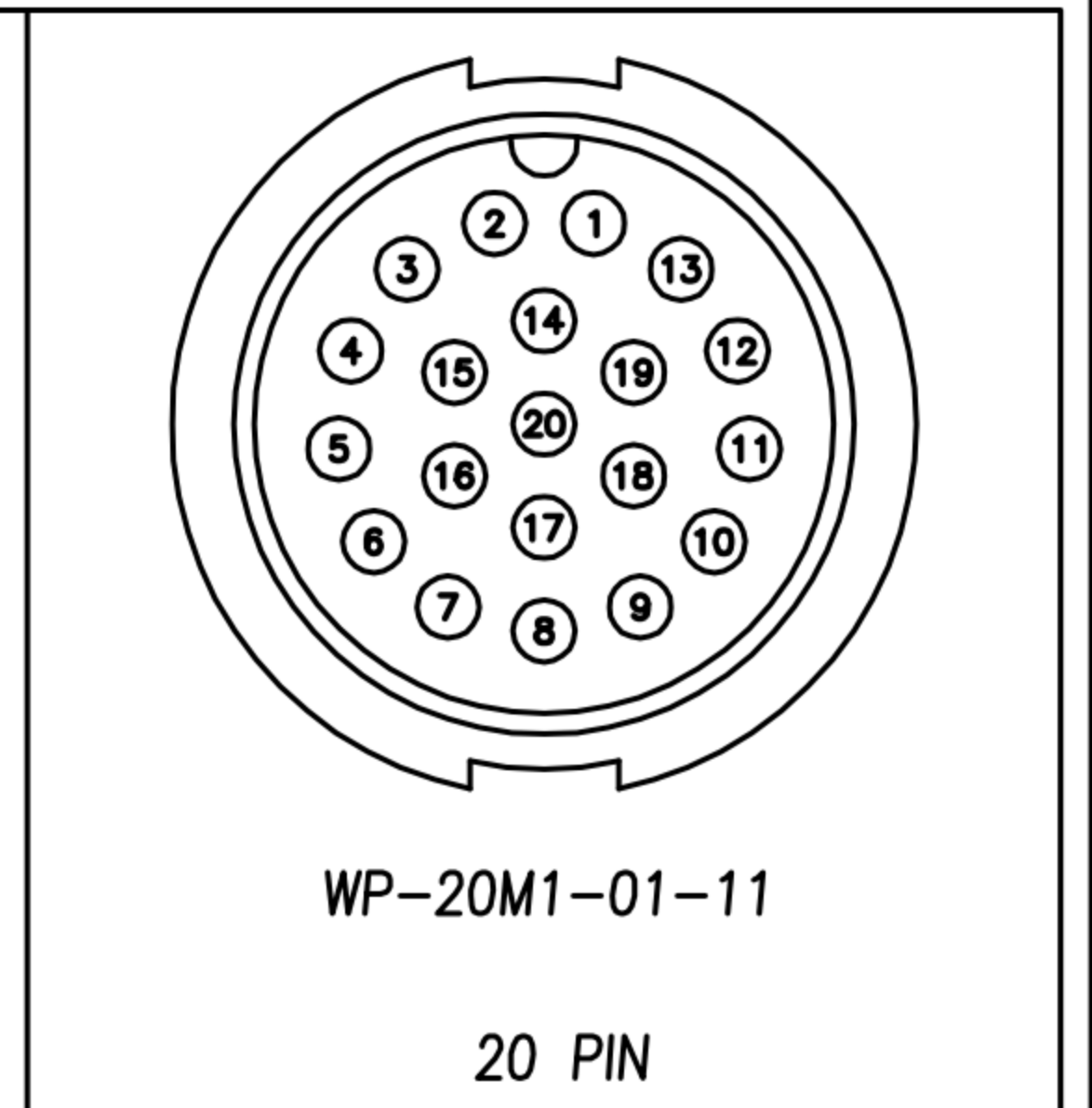
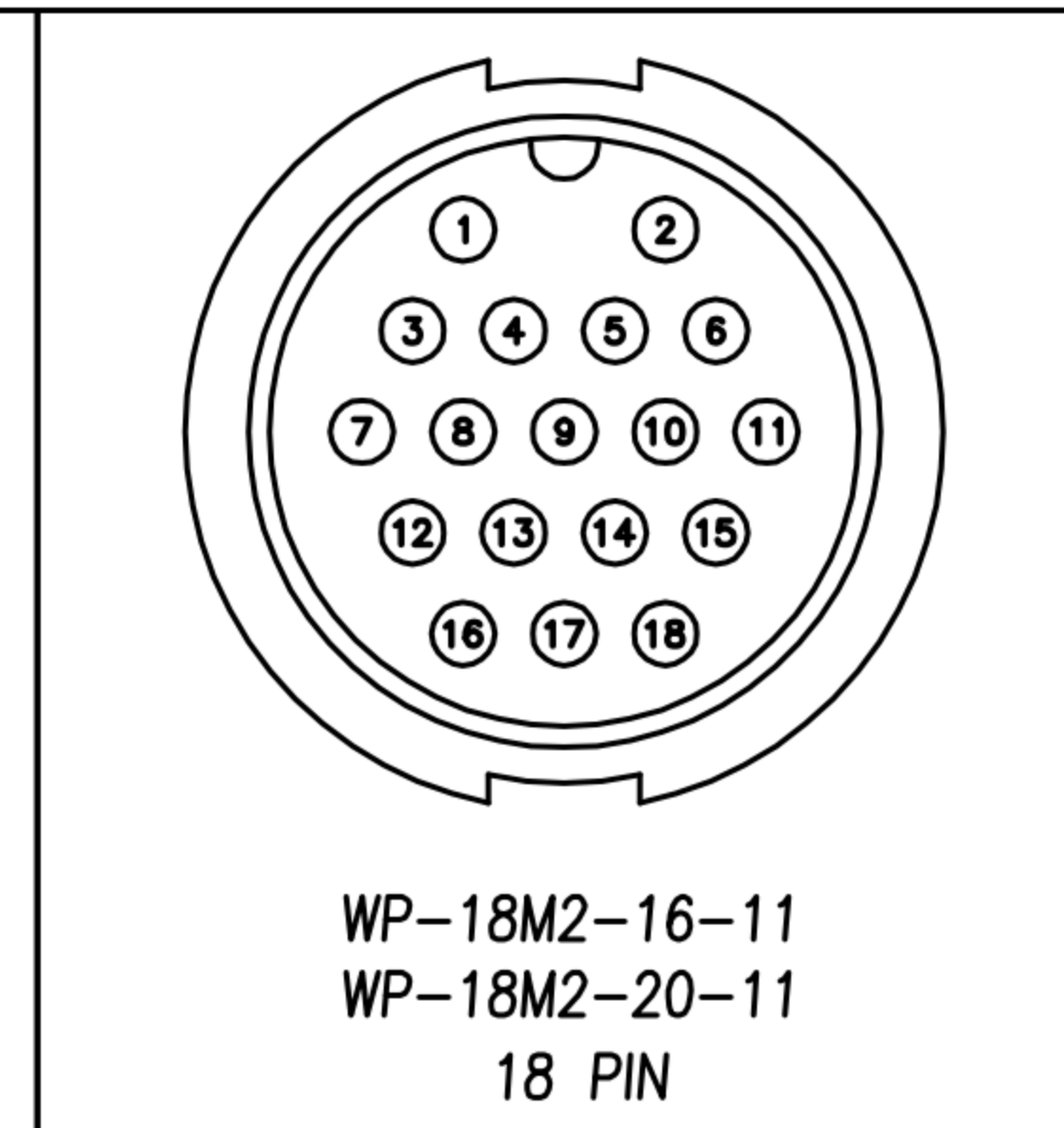
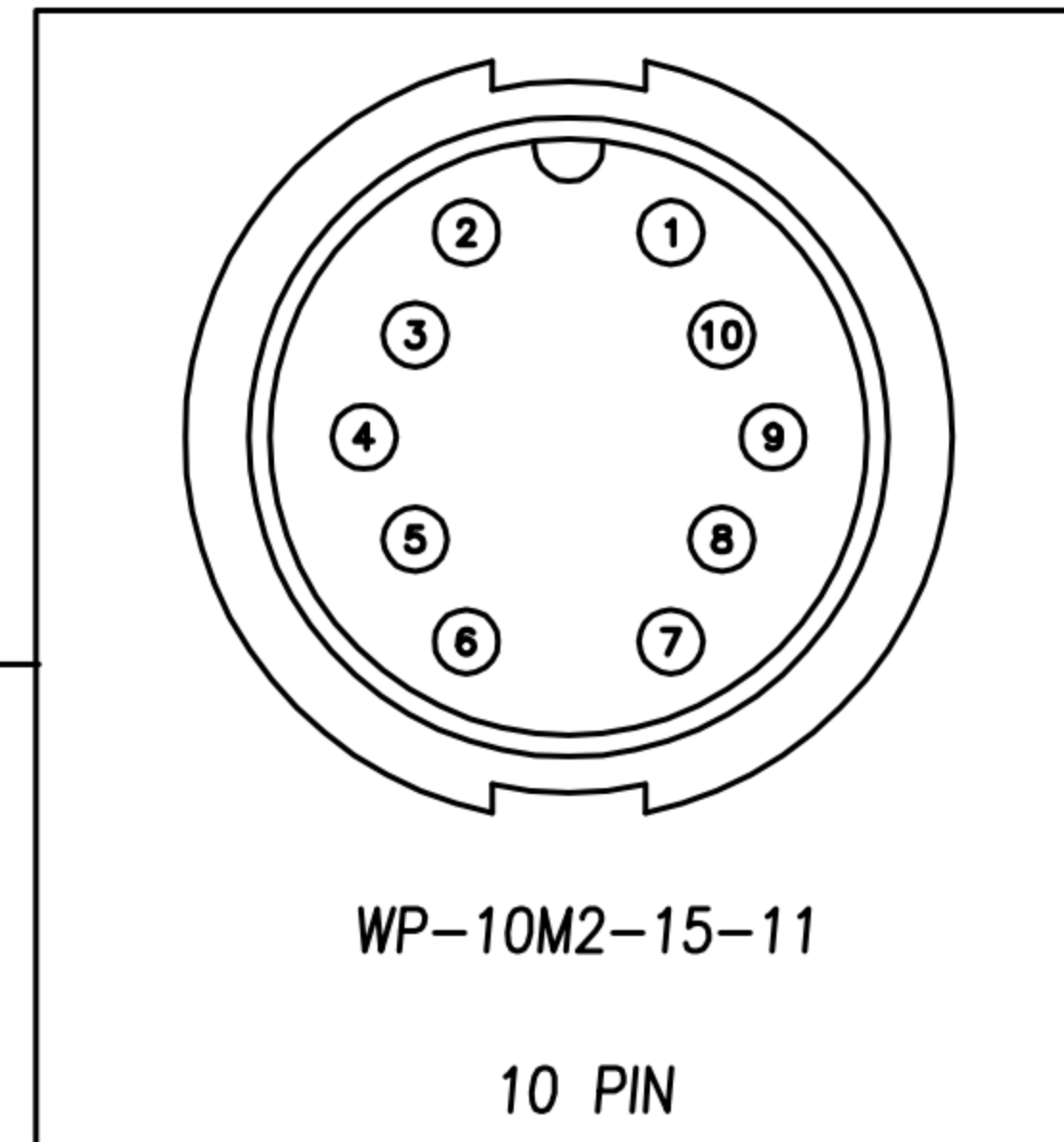
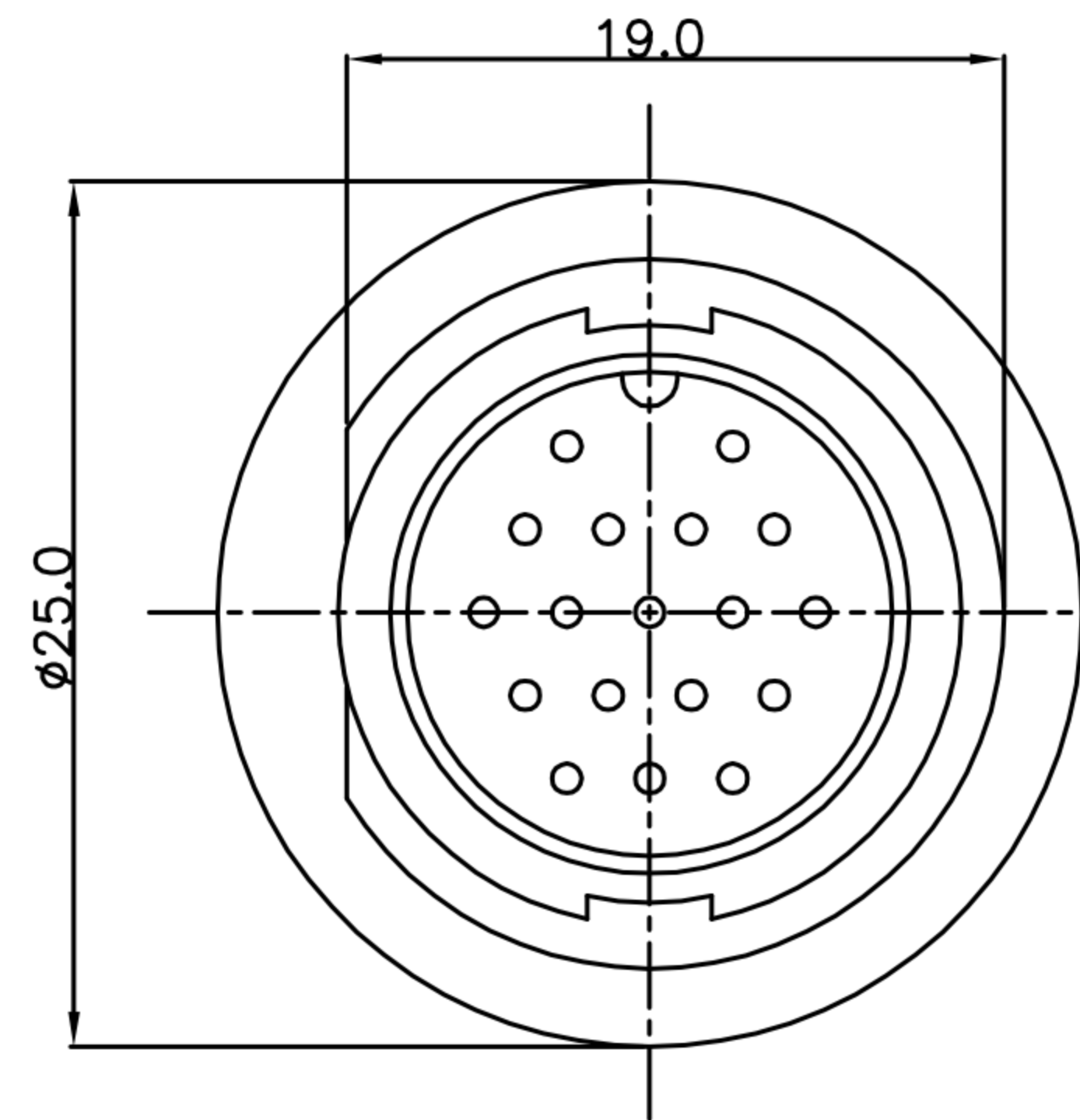
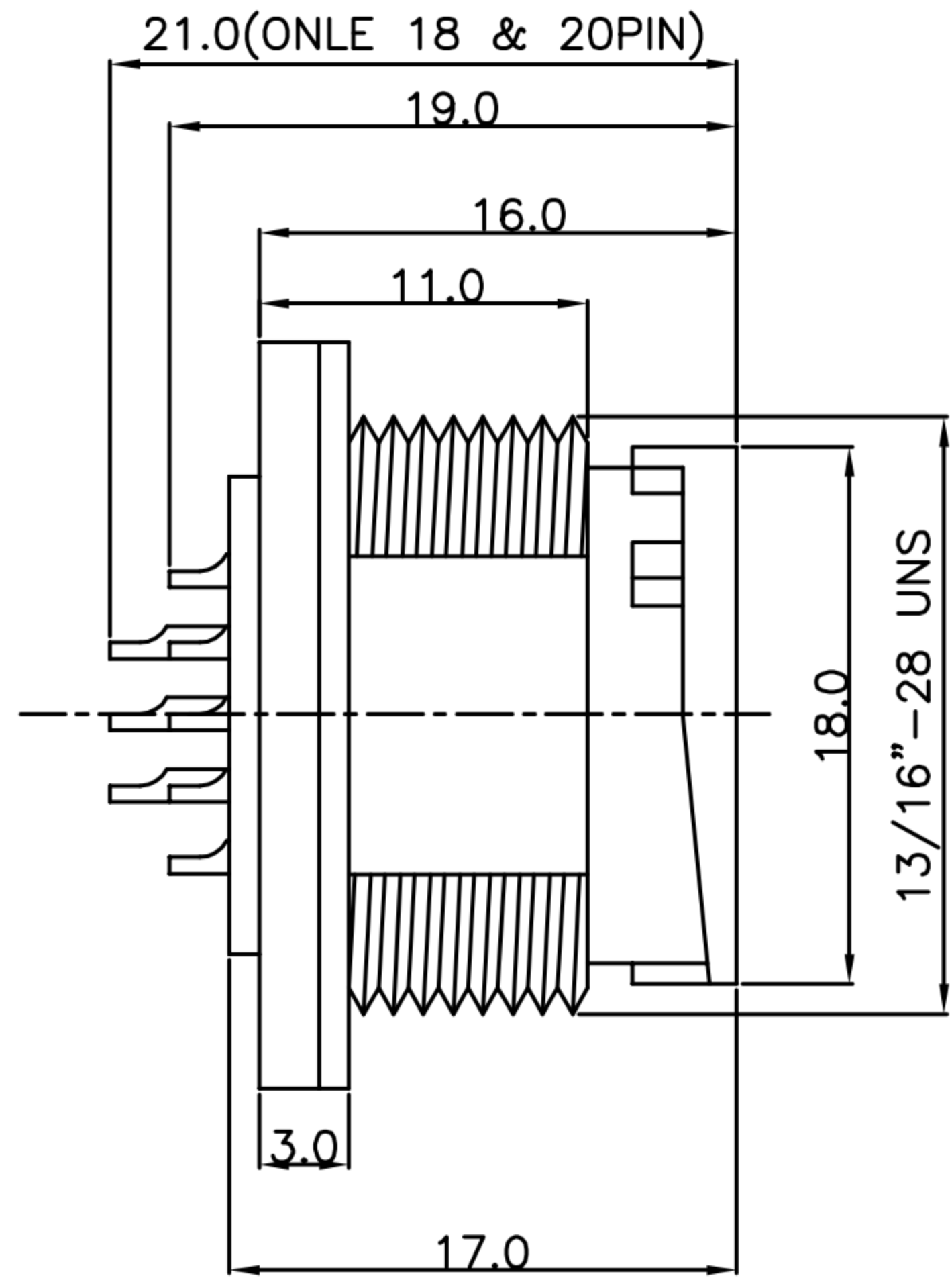

WP-18M2-20-11	6u" GOLD PLATED/金6u"
WP-20M1-01-11	GOLD FLASH PLATED/表金
WP-18M2-16-11	GOLD FLASH PLATED/表金
WP-10M2-15-11	GOLD FLASH PLATED/表金
P/N	FINISH

- MATERIAL :
  - 1-1. HOUSING : PA66
  - 1-2. CONTACT : BRASS
  - 1-3. GASKET : SILICONE
  - 1-4. HEX NUT : PA66
- FINISH :
  - 2-1. CONTACT : SEE TABLE A
- ELECTRICAL SPECIFICATION :
  - 3-1. Rated current : 2A
  - 3-2. Rated Voltage : 250V
  - 3-3. Water proof : IP67
- Environmental :
  - 4-1. Operation Temperature : -40°C~105°C

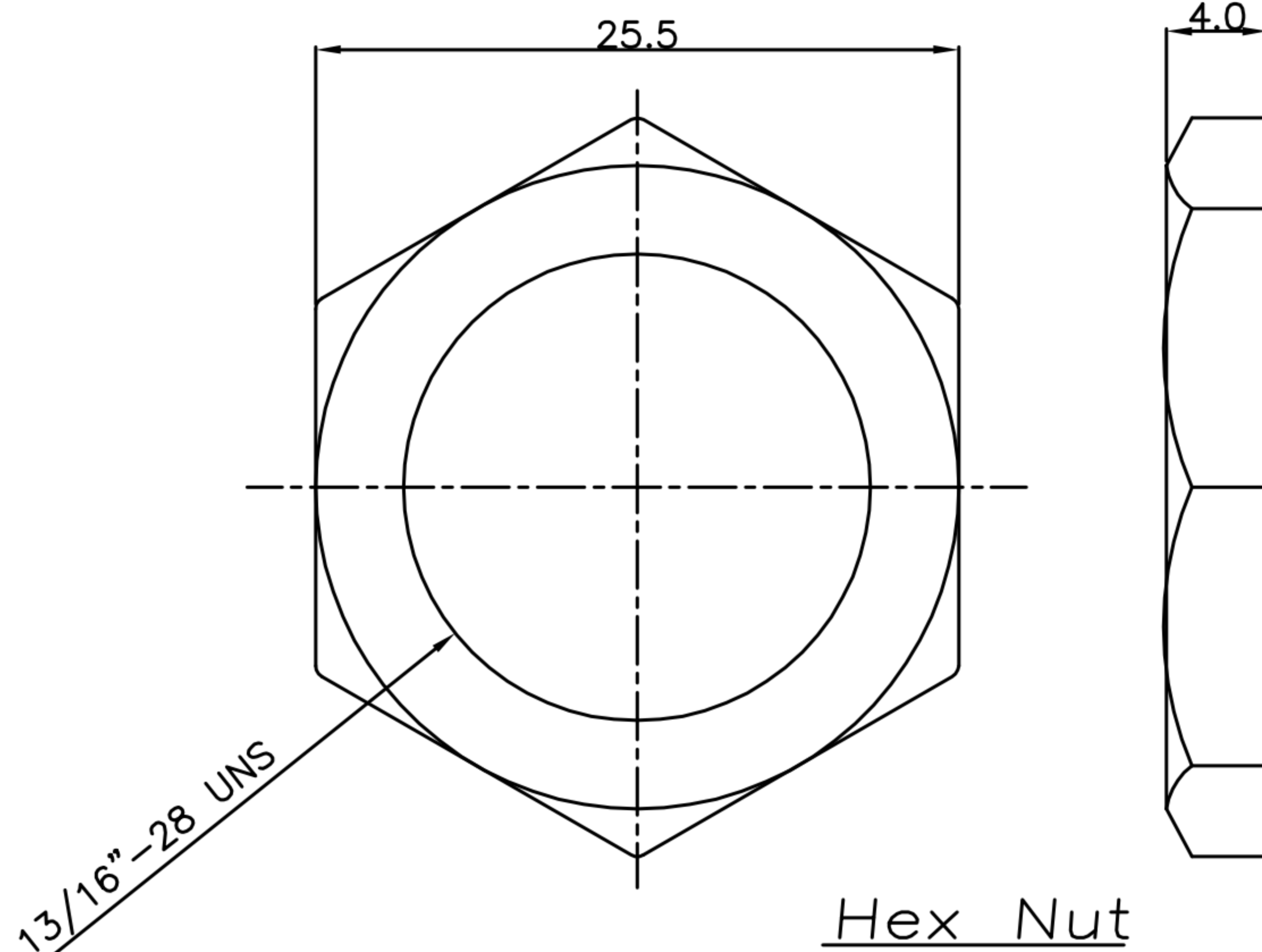
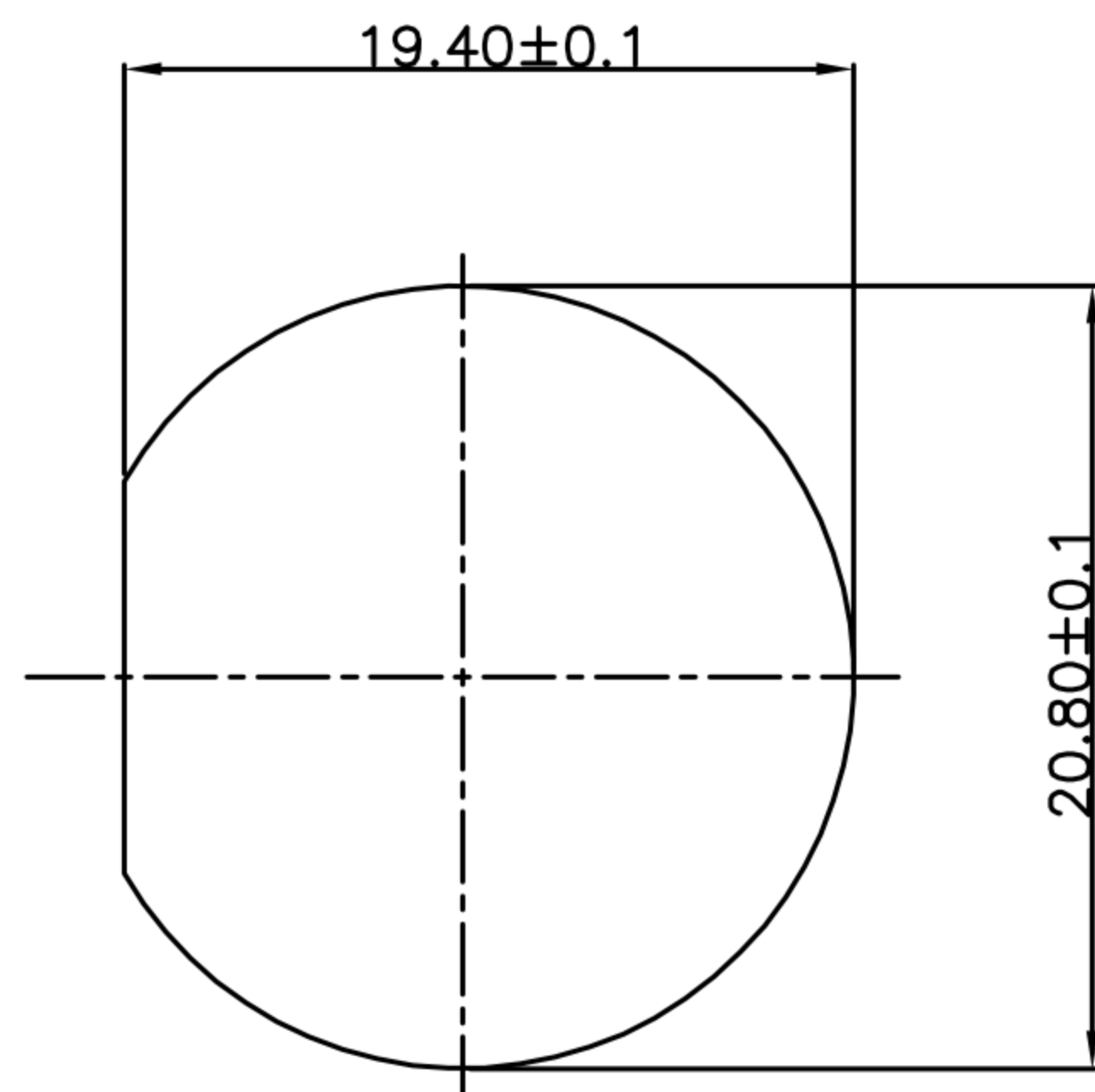

DRAWN	Emily Suen	APP'D	Ku Chou	UNIT	mm	TOLERANCE		TITLE	WP C Size(M) Front Lock Solder Type(Lock Bayonet)			SHEET	
CHK'D	Ku Chou			SCALE	1:1	.x ±0.20 .xx ±0.10 .xxx ±0.05 .xxxx ±0.03 ANGULA ±1°		广东科斯达电子科技有限公司 GUANG DONG KE SI DA ELECTRONIC TECHNOLOGY CO., LTD.	PART NO.	SEE TABLE A	DWG NO.	QC8563	VERSION A