

CUSTOMER DRAWING

REV.	DESCRIPTION	APPROVED BY	DATE	ECN NO.
A	RELEASE	KU Chou	09/05/18*	
B				
C				

TABLE A

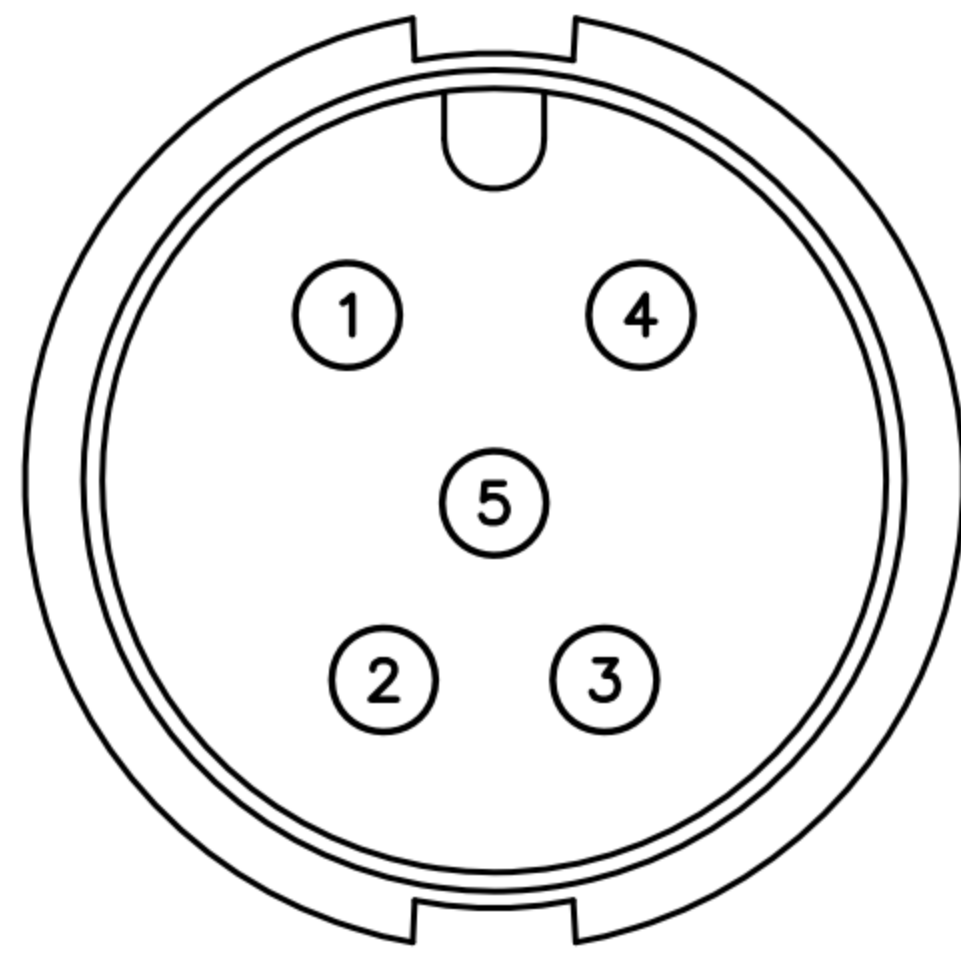

5P

WP-05M2-127-11

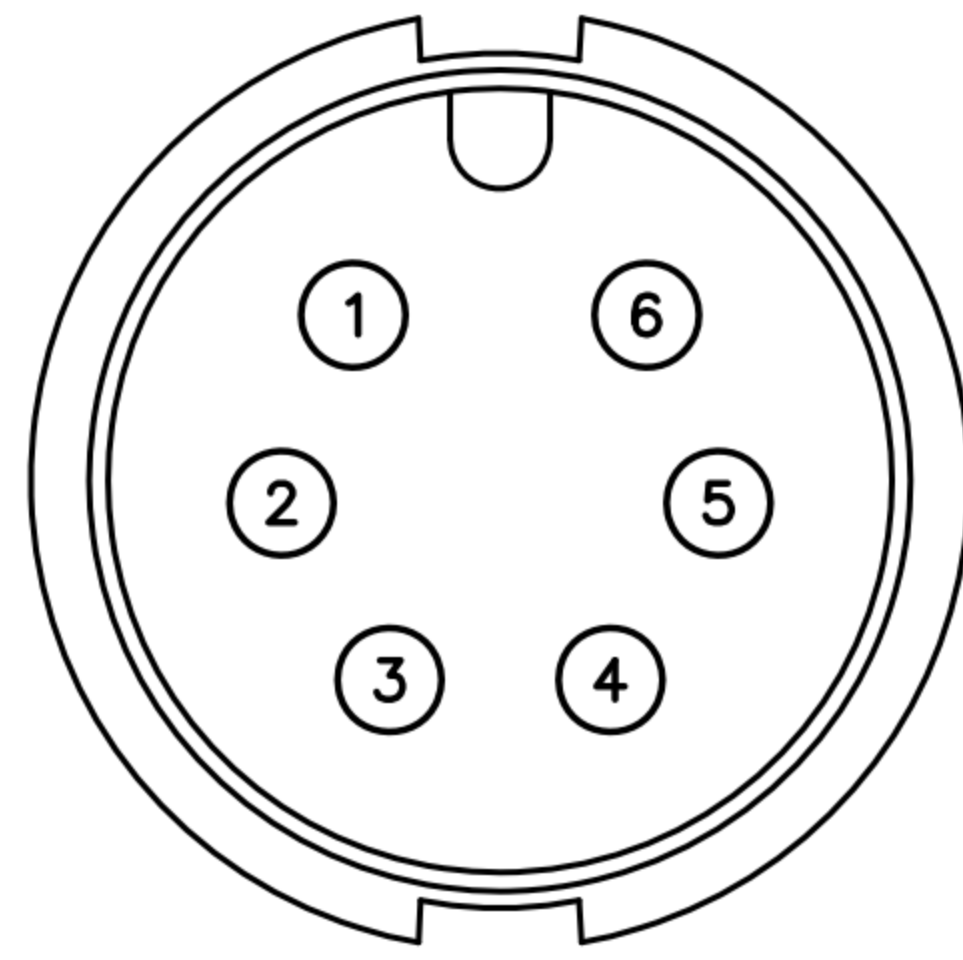

6P

WP-06M2-80-11

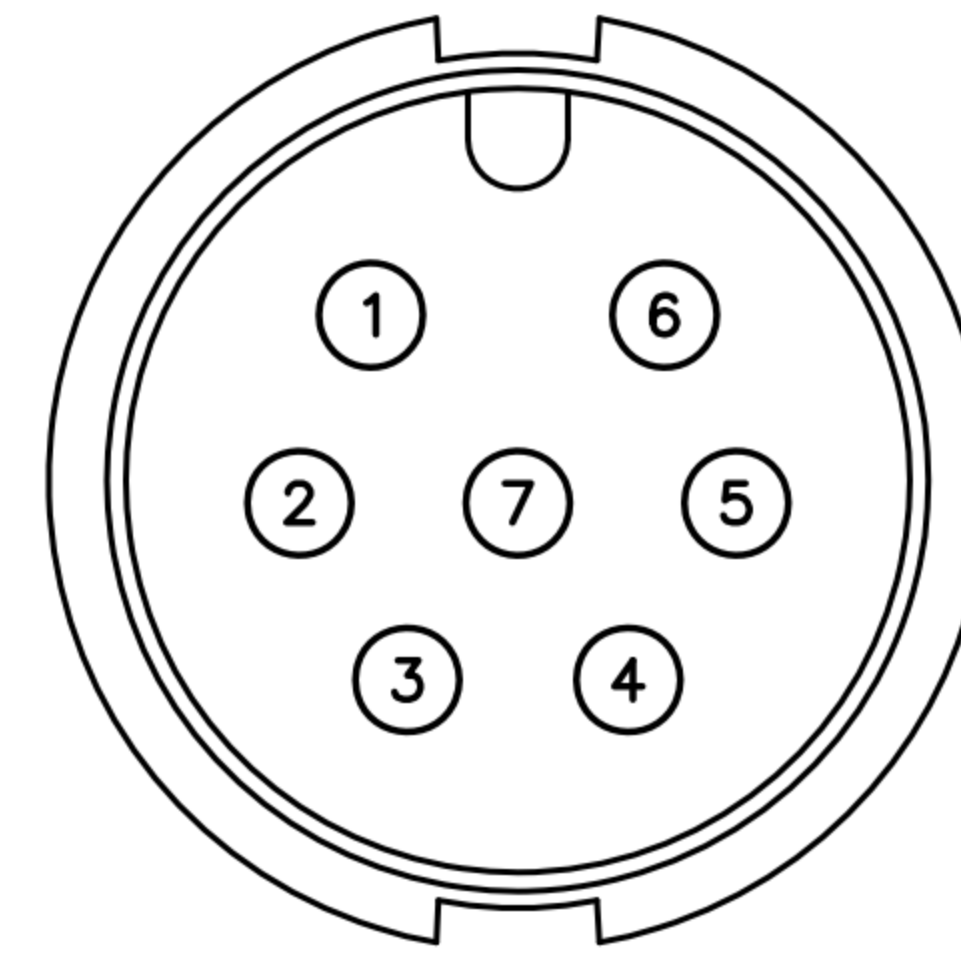

7P

WP-07M2-12-11

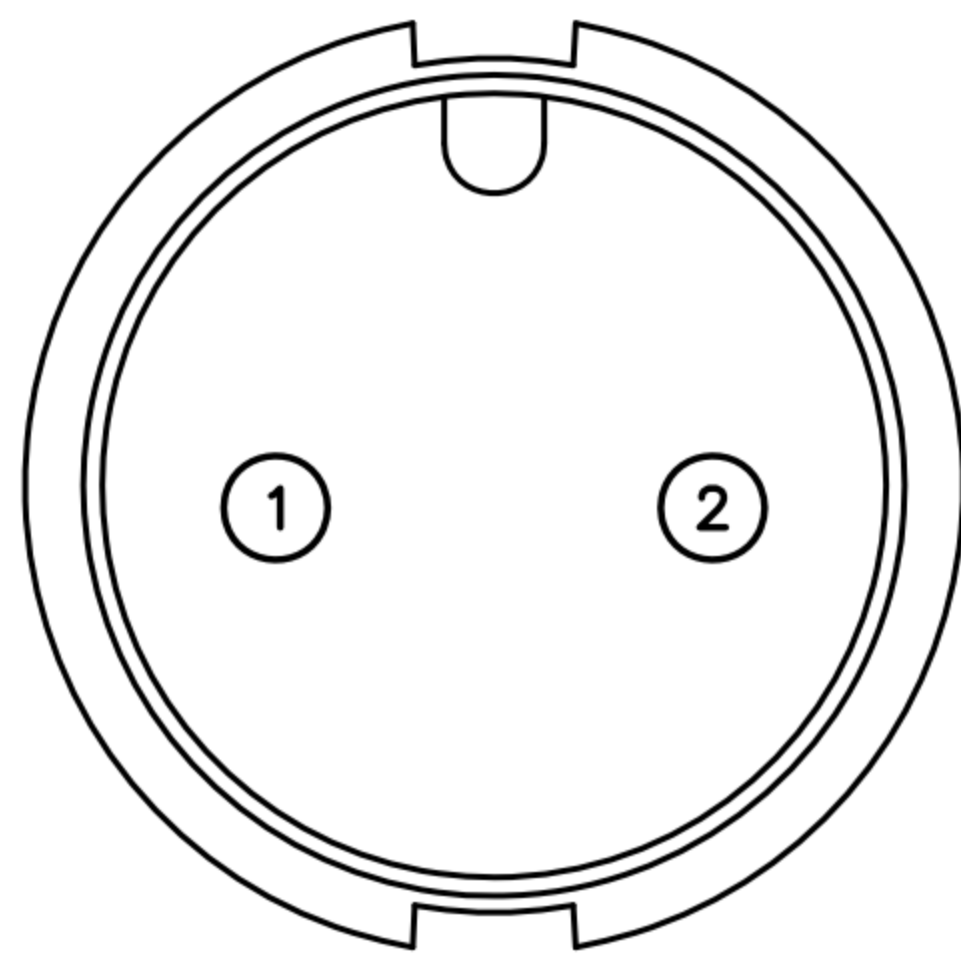

2P

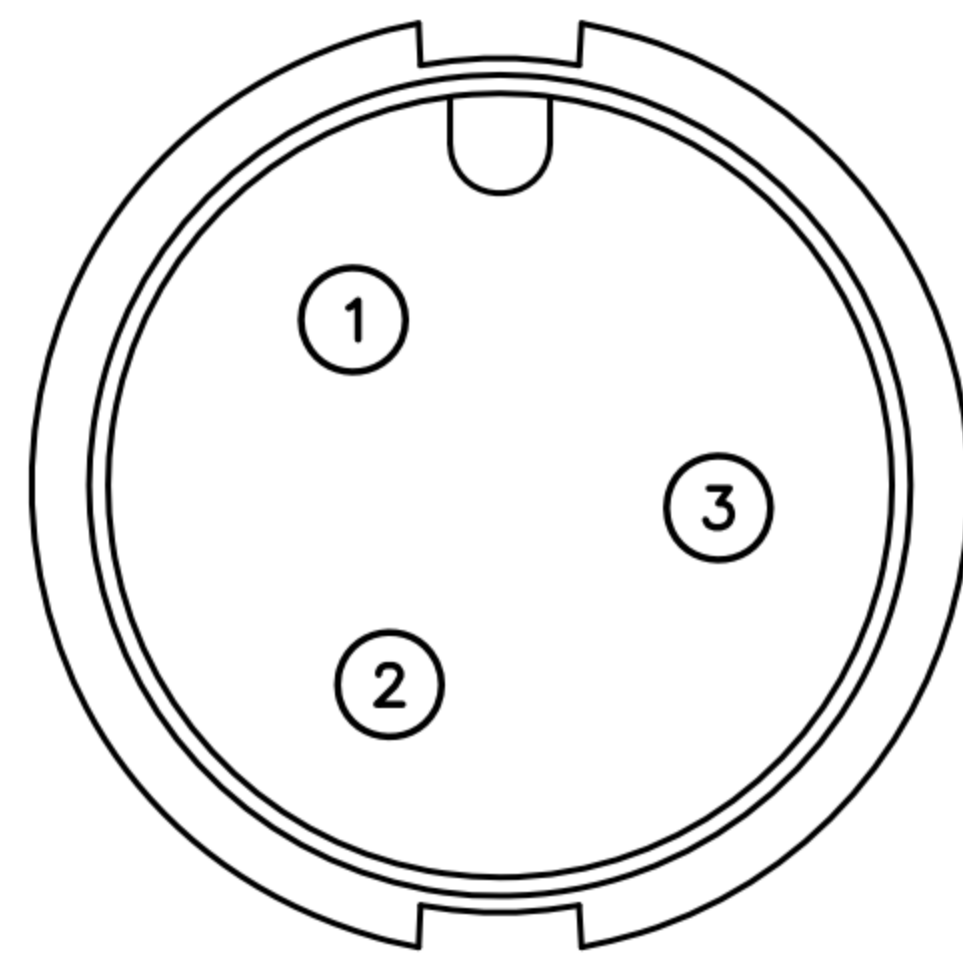

3P

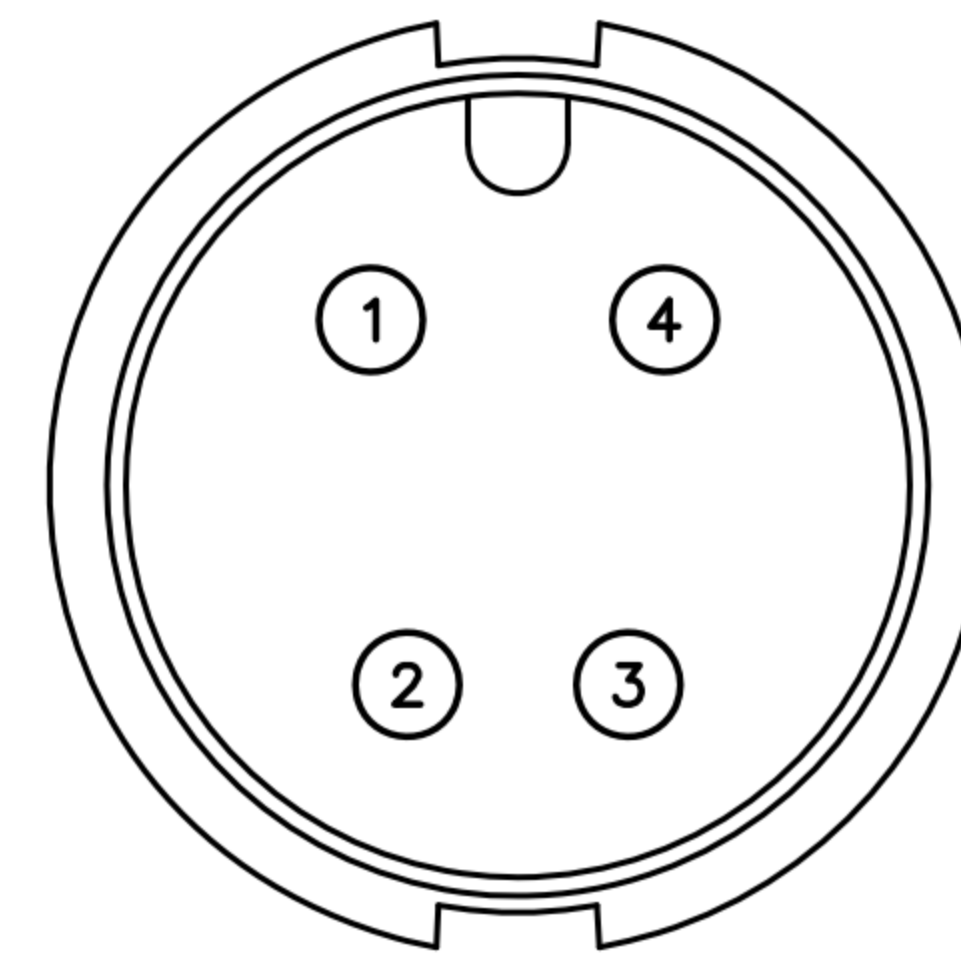

4P

WP-04M2-229-11

DRAWN	Emily Suen	APP'D	KU Chou	UNIT	mm	TOLERANCE		<p>广东科斯达电子科技有限公司 GUANG DONG KE SI DA ELECTRONIC TECHNOLOGY CO., LTD.</p>	TITLE	D SIZE (M) 快鎖杯口焊線式 (圓型槽板)-20A			SHEET	2/2
CHK'D	KU Chou			SCALE	1:1	.x ±0.20 .xx ±0.10 .xxx ±0.05 .xxxx ±0.03 ANGULA ±1°			PART NO.	SEE TABLE A	DWG NO.	QC8487	VERSION	A

# CUSTOMER DRAWING

REV.	DESCRIPTION	APPROVED BY	DATE	ECN NO.
A	RELEASE	Ku Chou	09/05/18'	
B				
C				

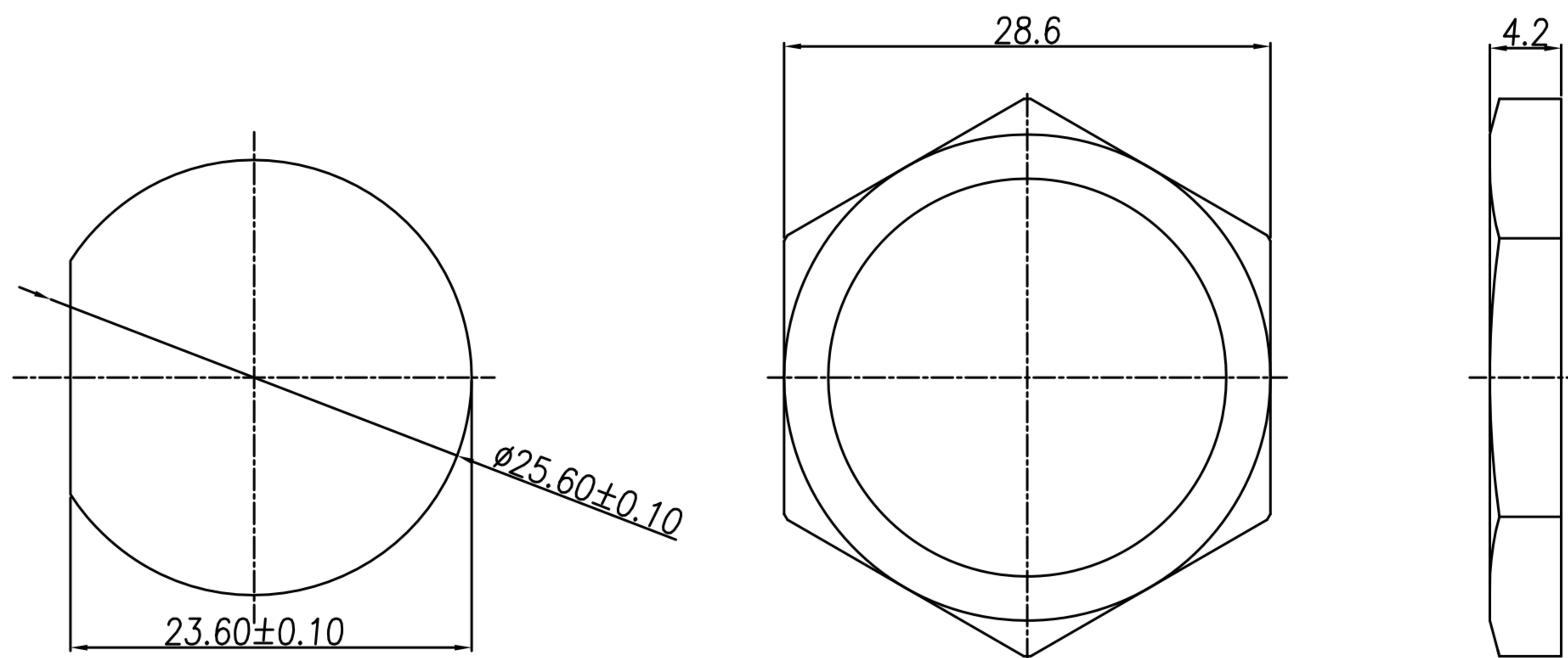
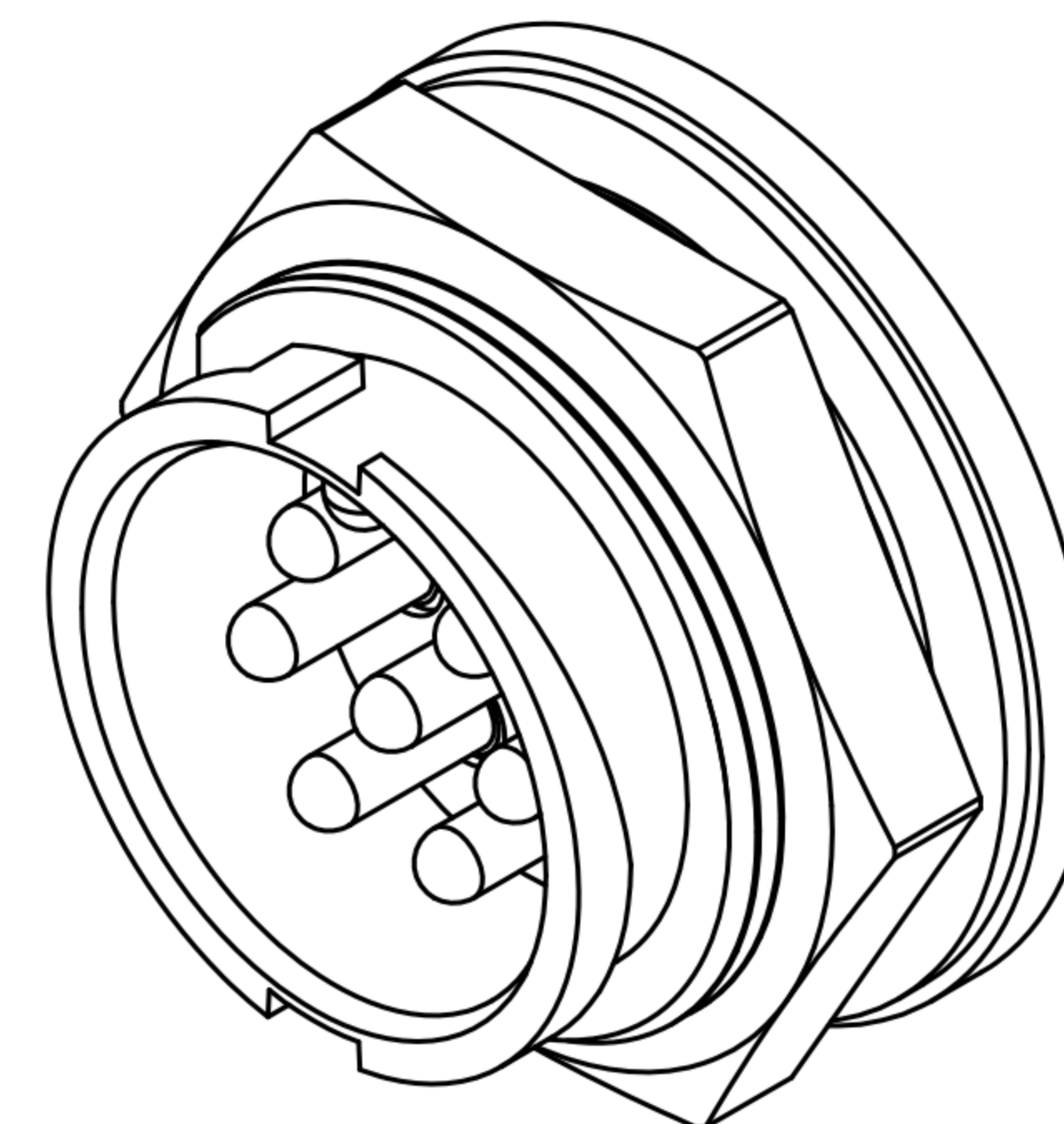
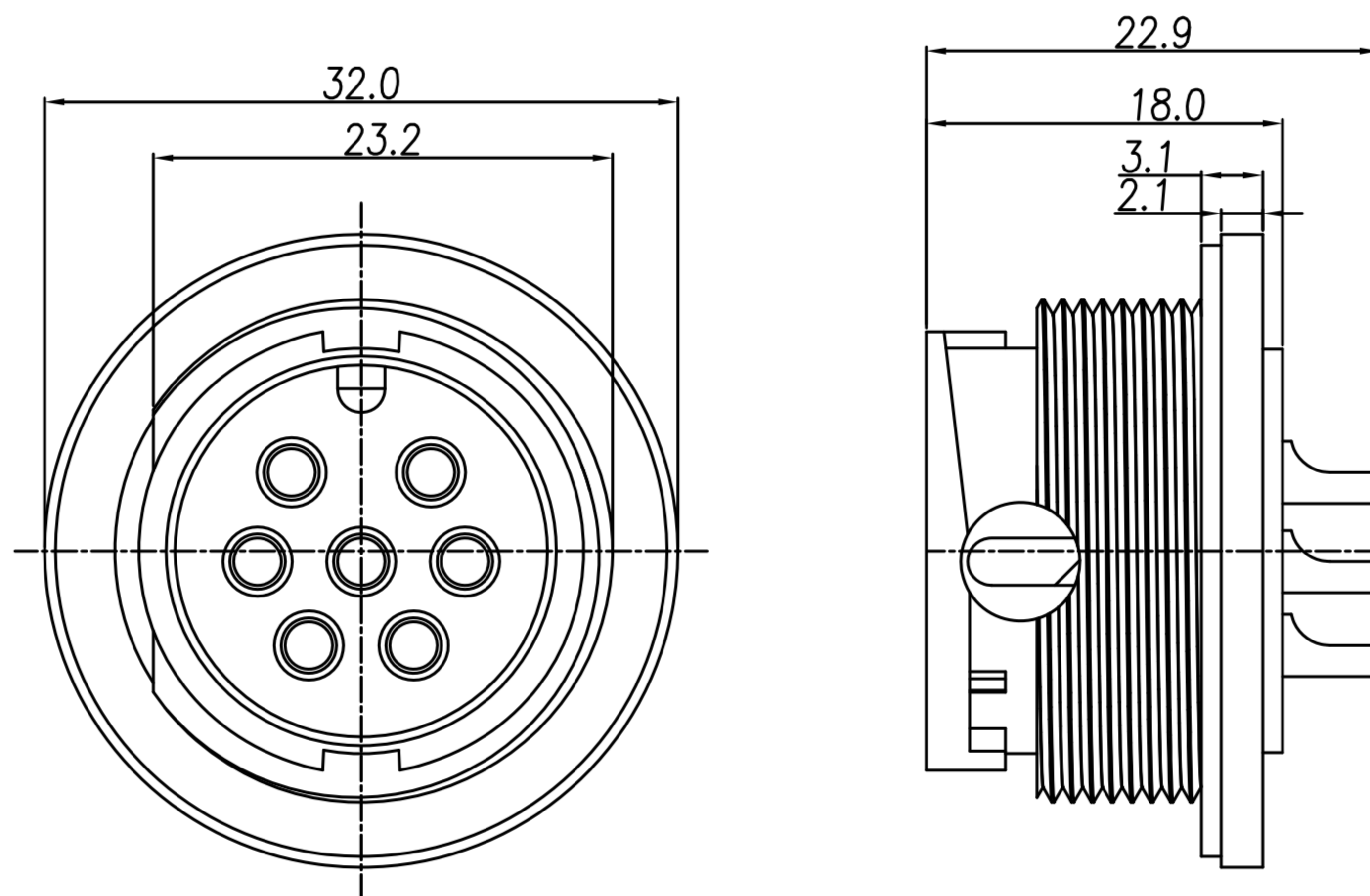

RECOMMEND PANEL HOLE

Hex Nut

1. MATERIAL :
  - 1-1. HOUSING : PA66
  - 1-2. CONTACT : BRASS
  - 1-3. GASKET : SILICONE
  - 1-4. HEX NUT : PA66
2. FINISH :
  - 2-1. CONTACT : GOLD FLASH PLATED
3. ELECTRICAL SPECIFICATION :
  - 3-1. Rated current : 20A
  - 3-2. Rated Voltage : 300V
4. Environmental :
  - 4-1. Operation Temperature : -40℃~105℃

DRAWN	Emily Suen	APP'D	KU Chou	UNIT	mm	TOLERANCE		广东科斯达电子科技有限公司 GUANG DONG KE SI DA ELECTRONIC TECHNOLOGY CO., LTD.	TITLE	D SIZE (M) 快锁杯口焊锡式 (圆型槽板)-20A			SHEET	1/2
CHK'D	KU Chou			SCALE	1:1	.x ±0.20 .xx ±0.10 .xxx ±0.05 .xxxx ±0.03 ANGULA ±1°			PART NO.	SEE TABLE A	DWG NO.	QC8487	VERSION	A