

CUSTOMER DRAWING

| REV. | DESCRIPTION | APPROVED BY | DATE | ECN NO. |
|------|-------------|-------------|-----------|---------|
| A | RELEASE | Ku Chou | 12/04/18* | |
| B | | | | |
| C | | | | |

TABLE A

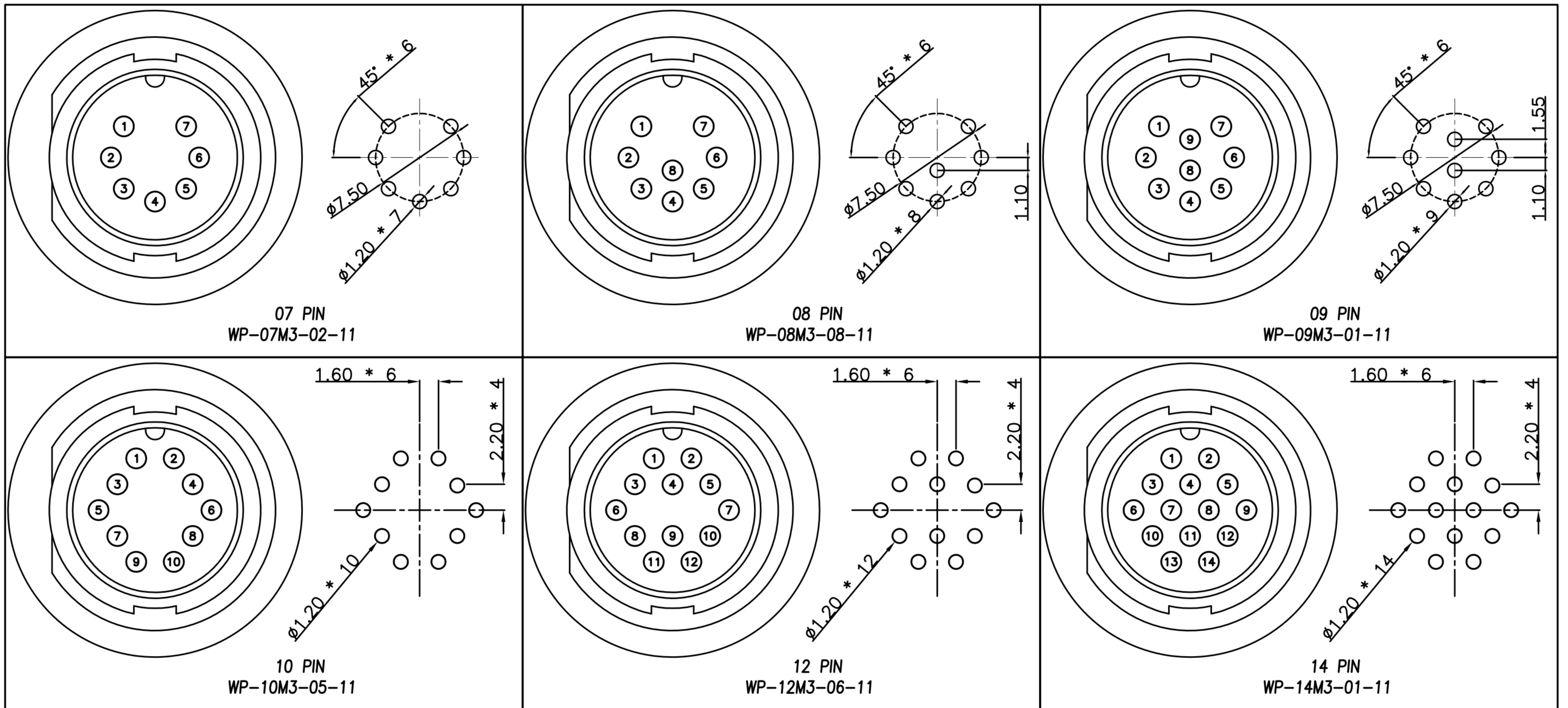

Pin Assignments and PCB Layout Front View

| | | | | | | | | | | | | | |
|-------|------------|-------|---------|-------|-----|--|--|-------|--|-------------|---------|--------------|-----|
| DRAWN | Emily Suen | APP'D | Ku Chou | UNIT | mm | TOLERANCE | | TITLE | WP C Size(M) Front Lock DIP Type(Lock Bayonet) | | | SHEET | |
| CHK'D | Ku Chou | | | SCALE | 1:1 | .x ±0.20 .xx ±0.10 .xxx ±0.05 .xxxx ±0.03 ANGULA ±1° | | | PART NO. | SEE TABLE A | DWG NO. | QC8267 | 2/2 |
| | | | | | | | | | | | | VERSION A | |

CUSTOMER DRAWING

| REV. | DESCRIPTION | APPROVED BY | DATE | ECN NO. |
|------|-------------|-------------|-----------|---------|
| A | RELEASE | Ku Chou | 12/04/18* | |
| B | | | | |
| C | | | | |

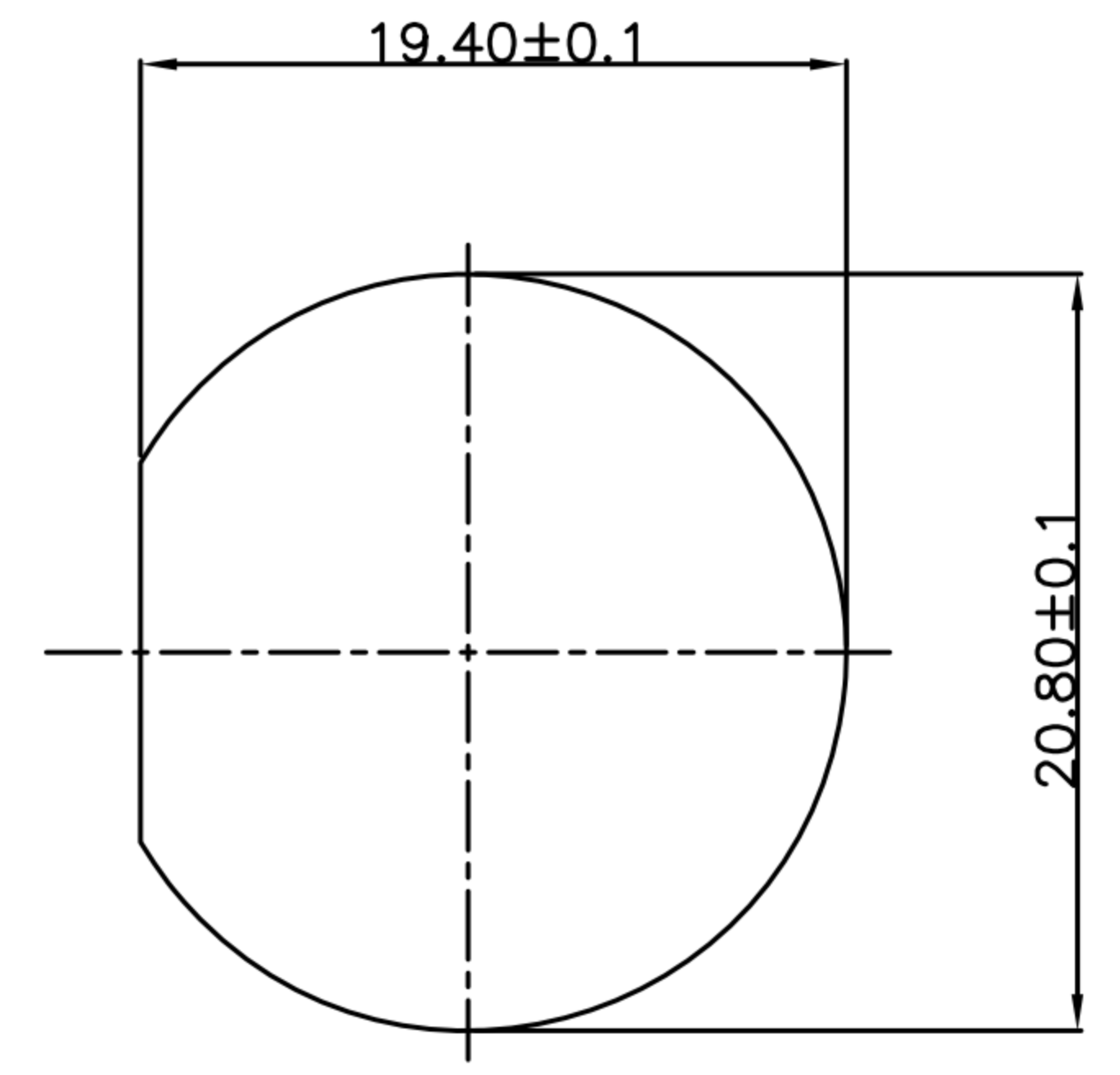
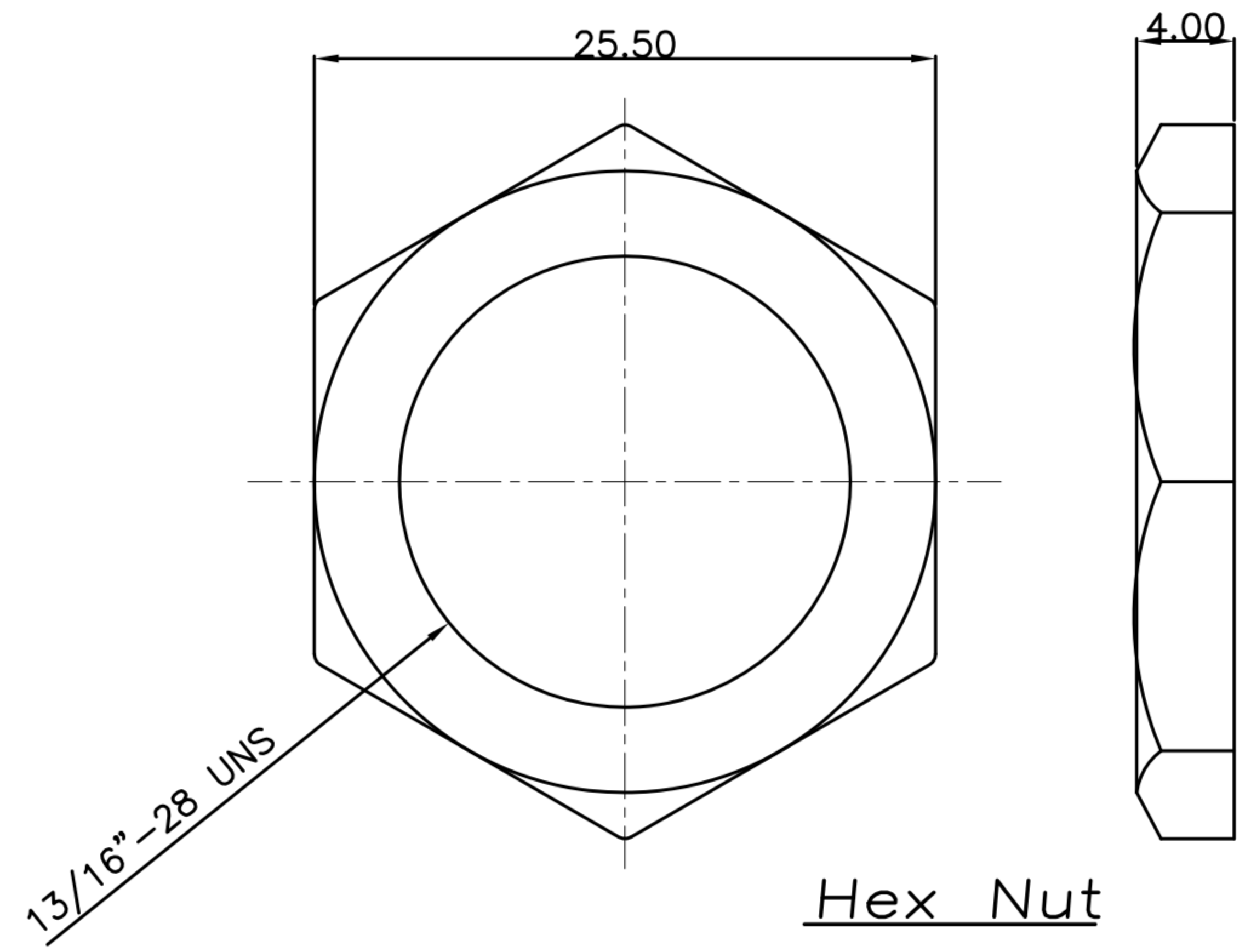
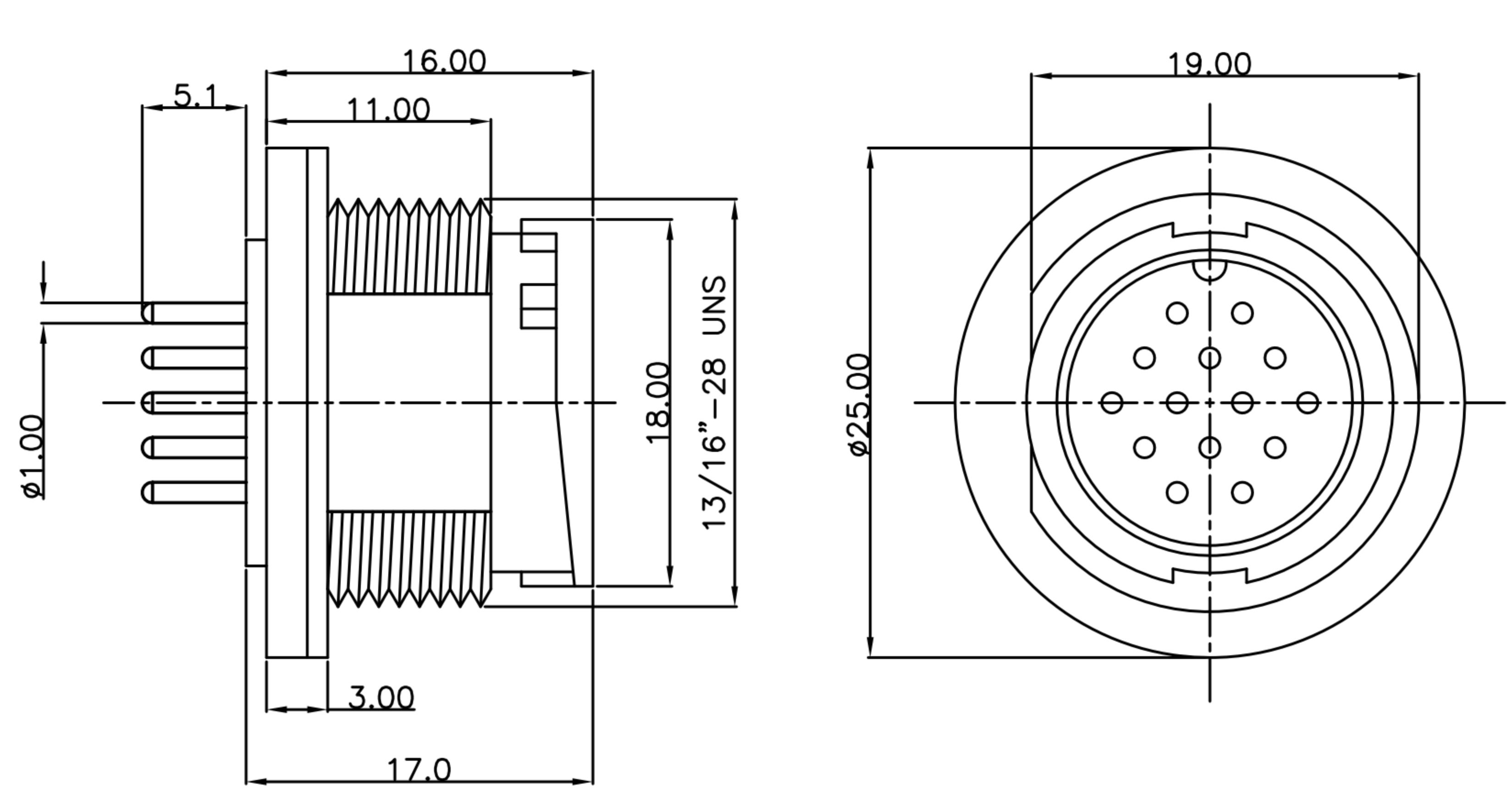

RECOMMEND PANEL CUT-OUT

- MATERIAL :
 - 1-1. HOUSING : PA66
 - 1-2. CONTACT : BRASS
 - 1-3. GASKET : SILICONE
 - 1-4. HEX NUT : PA66
- FINISH :
 - 2-1. CONTACT : GOLD FLASH PLATED.
- ELECTRICAL SPECIFICATION :
 - 3-1. Rated current : 5A
 - 3-2. Rated Voltage : 250V
 - 3-3. Water proof : IP67
- Environmental :
 - 4-1. Operation Temperature : -40℃~105℃

| | | | | | | | | | | | | | |
|-------|------------|-------|---------|-------|-----|--|--|--|----------|--|---------|--------|---------|
| DRAWN | Emily Suen | APP'D | Ku Chou | UNIT | mm | TOLERANCE | | 广东科斯达电子科技有限公司 GUANG DONG KE SI DA ELECTRONIC TECHNOLOGY CO., LTD. | TITLE | WP C Size(M) Front Lock DIP Type(Lock Bayonet) | | | SHEET |
| CHK'D | Ku Chou | | | SCALE | 1:1 | .x ±0.20 .xx ±0.10 .xxx ±0.05 .xxxx ±0.03 ANGULA ±1° | | | PART NO. | SEE TABLE A | DWG NO. | QC8267 | VERSION |