

CUSTOMER DRAWING

REV.	DESCRIPTION	APPROVED BY	DATE	ECN NO.
A	RELEASE	Yeh Chou	2016/06/02	
B				
C				

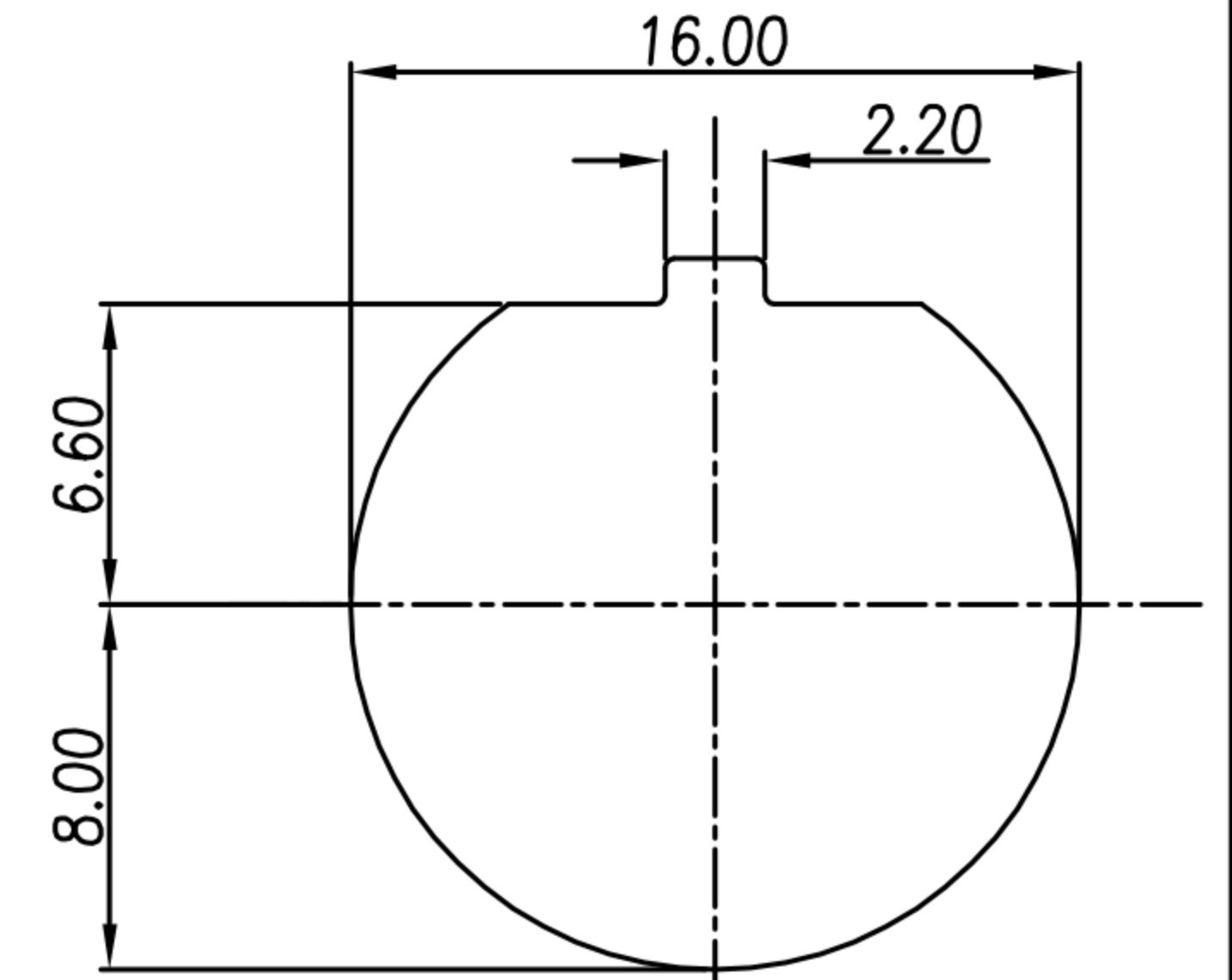

PANEL CUT-OUT

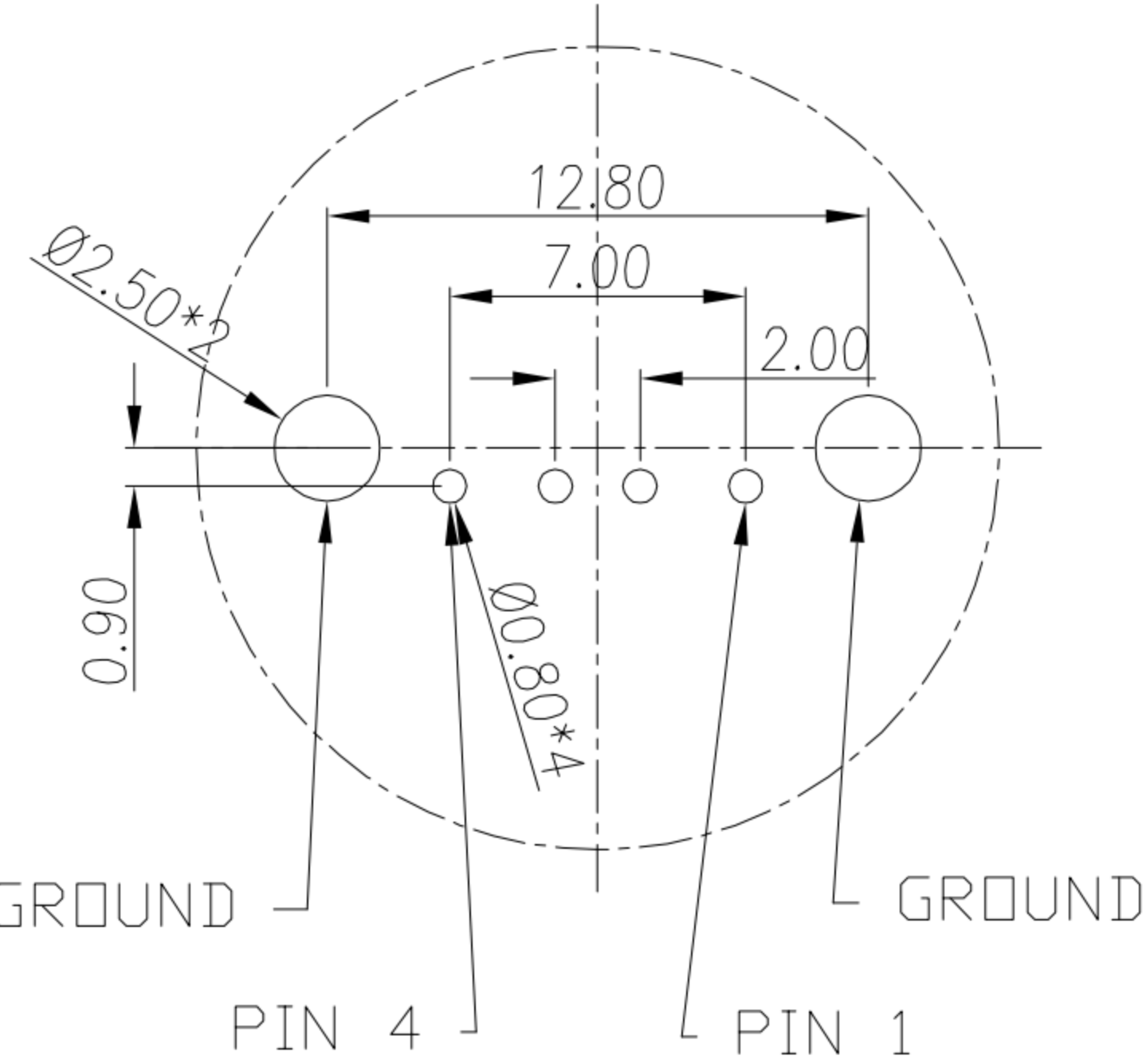
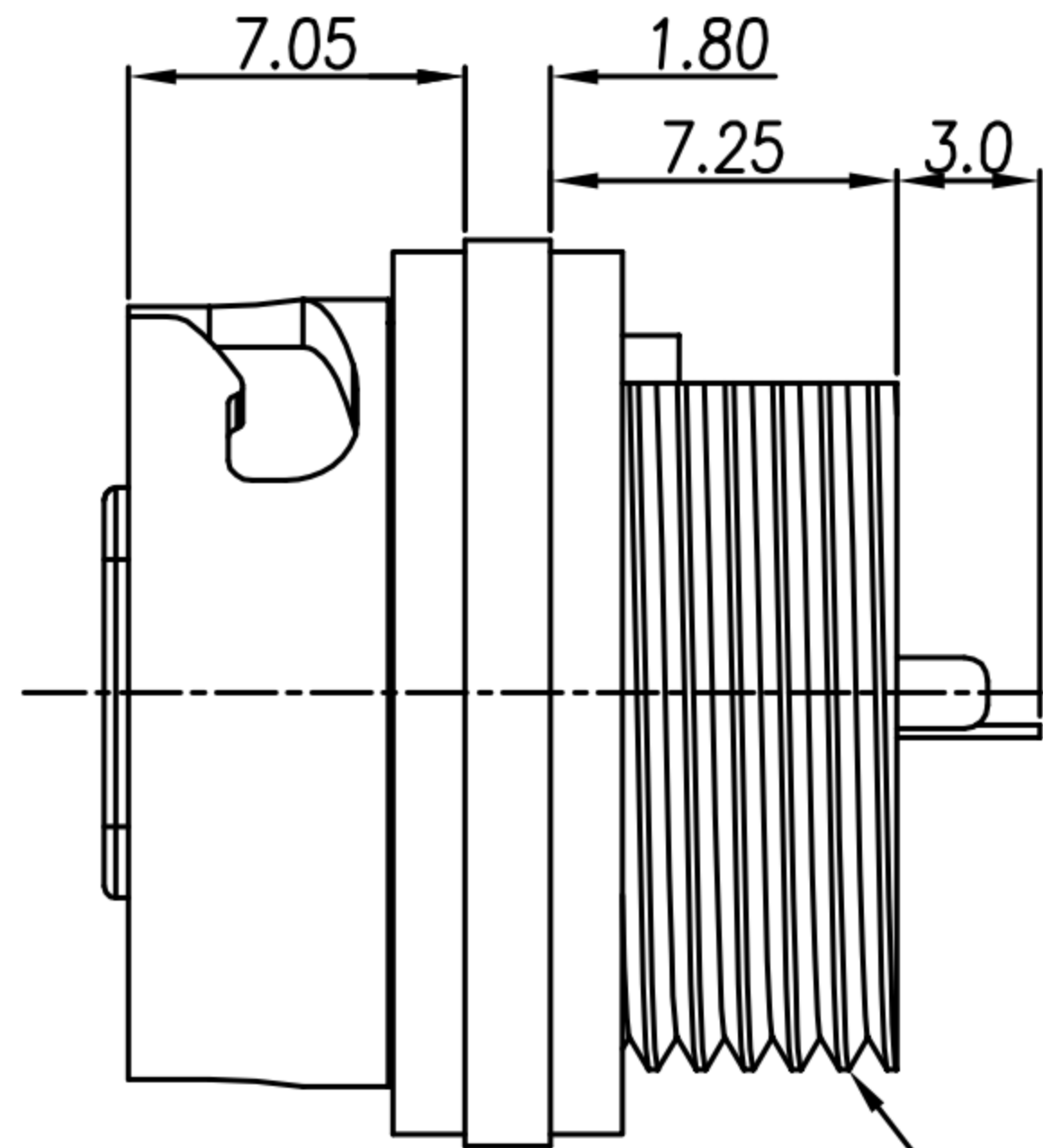
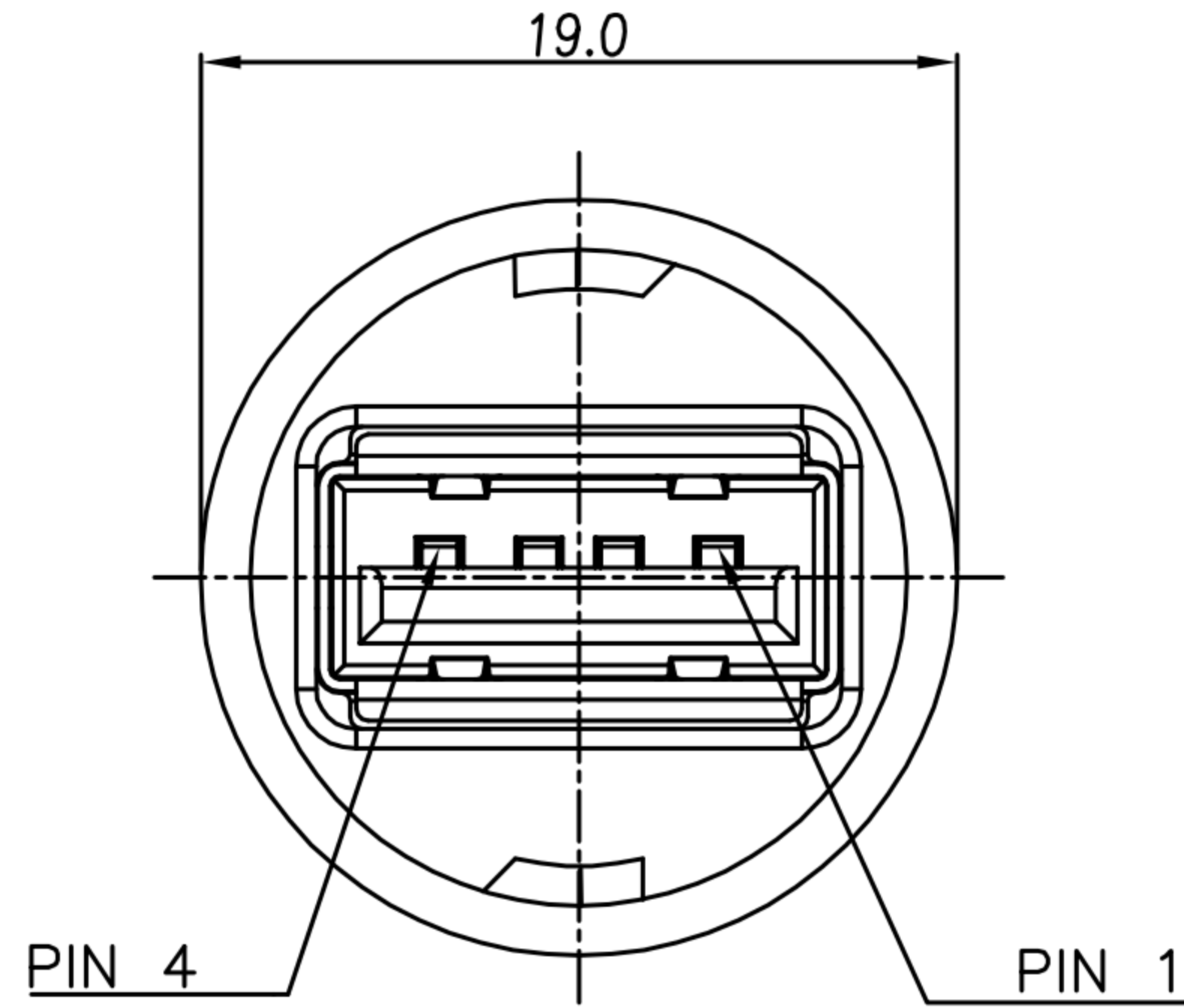
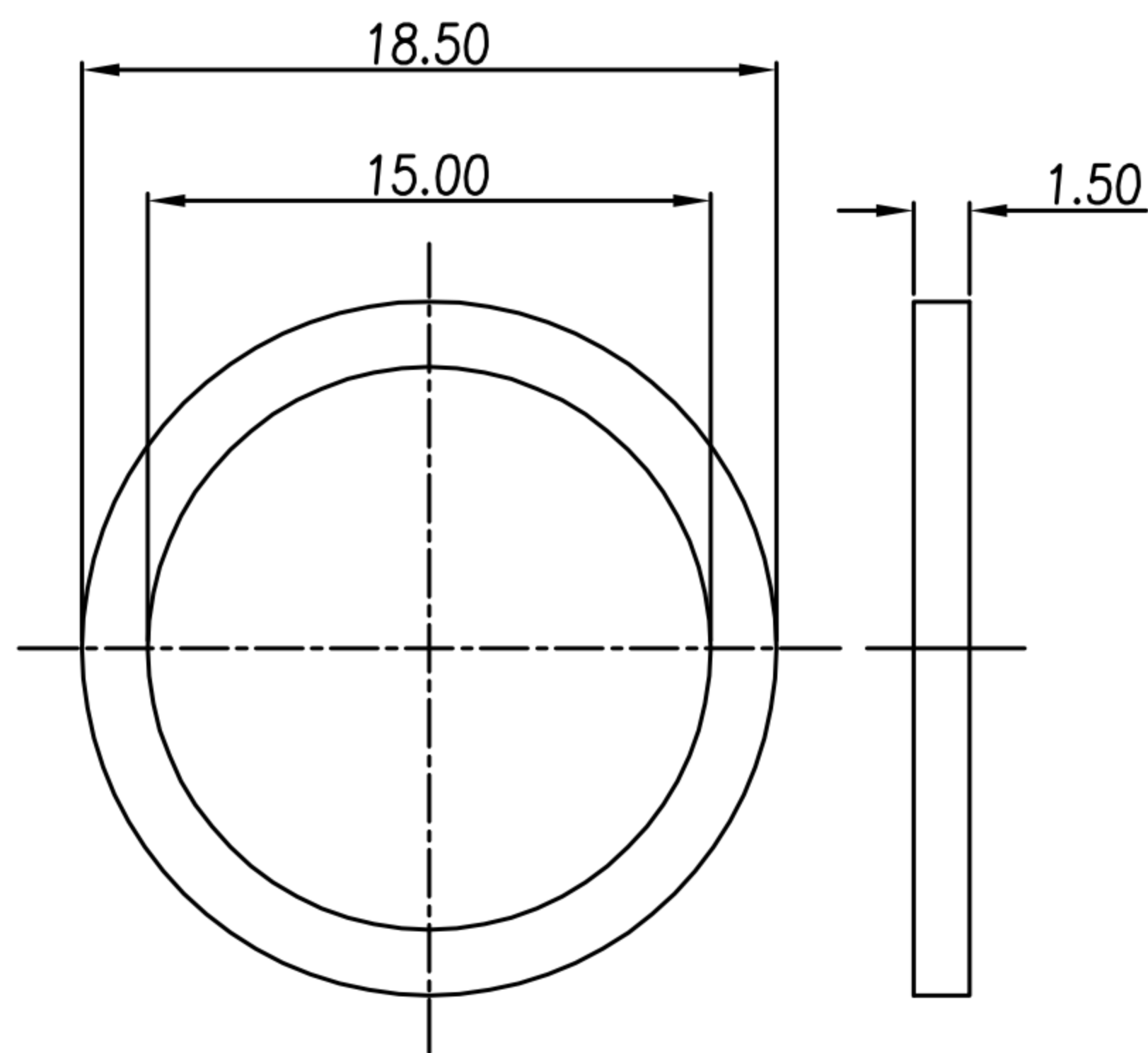

O-RING

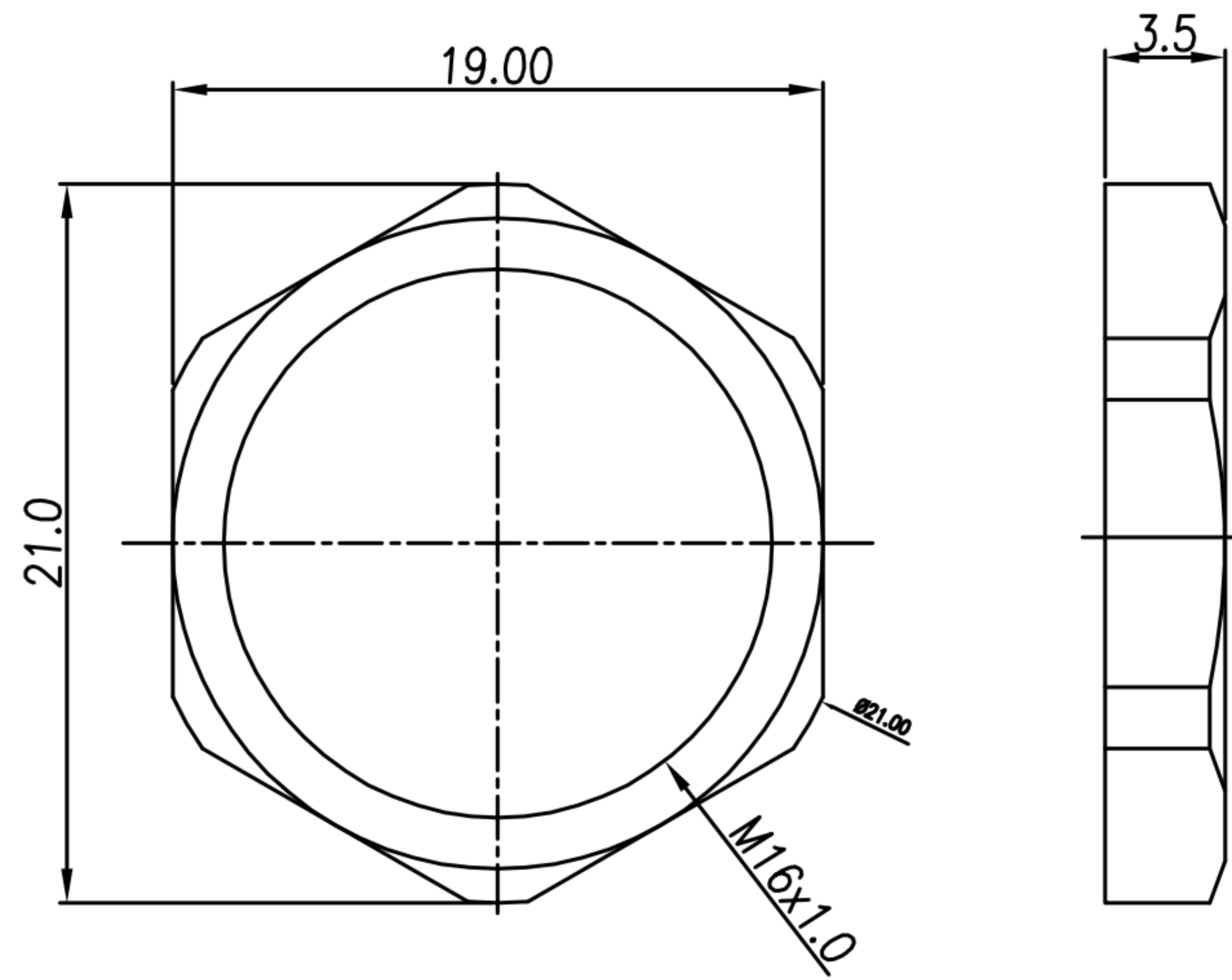

NUT

1. MATERIAL :
 - 1-1. HOUSING : PBT UL94V-0 ; COLOR : BLACK
 - 1-2. CONTACT : PHOSPHOR BRONZE
 - 1-3. SHELL : BRASS
 - 1-4. O-RING A : SILICON ; COLOR : ORANGE
 - 1-4. O-RING B : SILICON ; COLOR : ORANGE
 - 1-5. NUT : PBT
2. FINISH :
 - 2-1. CONTACT : GOLD FLASH
 - SOLDER AREA : TIN 100u".
 - UNDER PLATE : NICKEL
 - 2-2. SHELL : NICKEL

DRAWN	Ren Liao	APP'D	Fido Weng	UNIT	mm	TOLERANCE			TITLE	防水 USB A(F)後鎖焊線式 M16x1.0			SHEET	1
CHK'D	Emily Suen			SCALE	1:1	.x ±0.20 .xx ±0.10 .xxx ±0.05 .xxxx ±0.03 ANGULA ±1°			PART NO.	US-04F3-28-11	DWG NO.	QC7528	VERSION	A