

# CUSTOMER DRAWING

REV.	DESCRIPTION	APPROVED BY	DATE	ECN NO.
△A	RELEASE	Ku Chou	02/04/18'	
△B	CHANGE BOM	Ku Chou	10/09/18'	
△C	CHANGE CLAMP RING MATERIAL	Ku Chou	30/10/18'	

TABLE A

P/N	MATERIAL(CLAMP RING)	CABLE ODφ
WP-03F2-95-11	PA66	φ8.6mm~φ9.6mm
		φ6.5mm~φ7.6mm
WP-03F2-102-11	PBT+PC, UL94V-0(F1)	φ8.6mm~φ9.6mm
		φ6.5mm~φ7.6mm

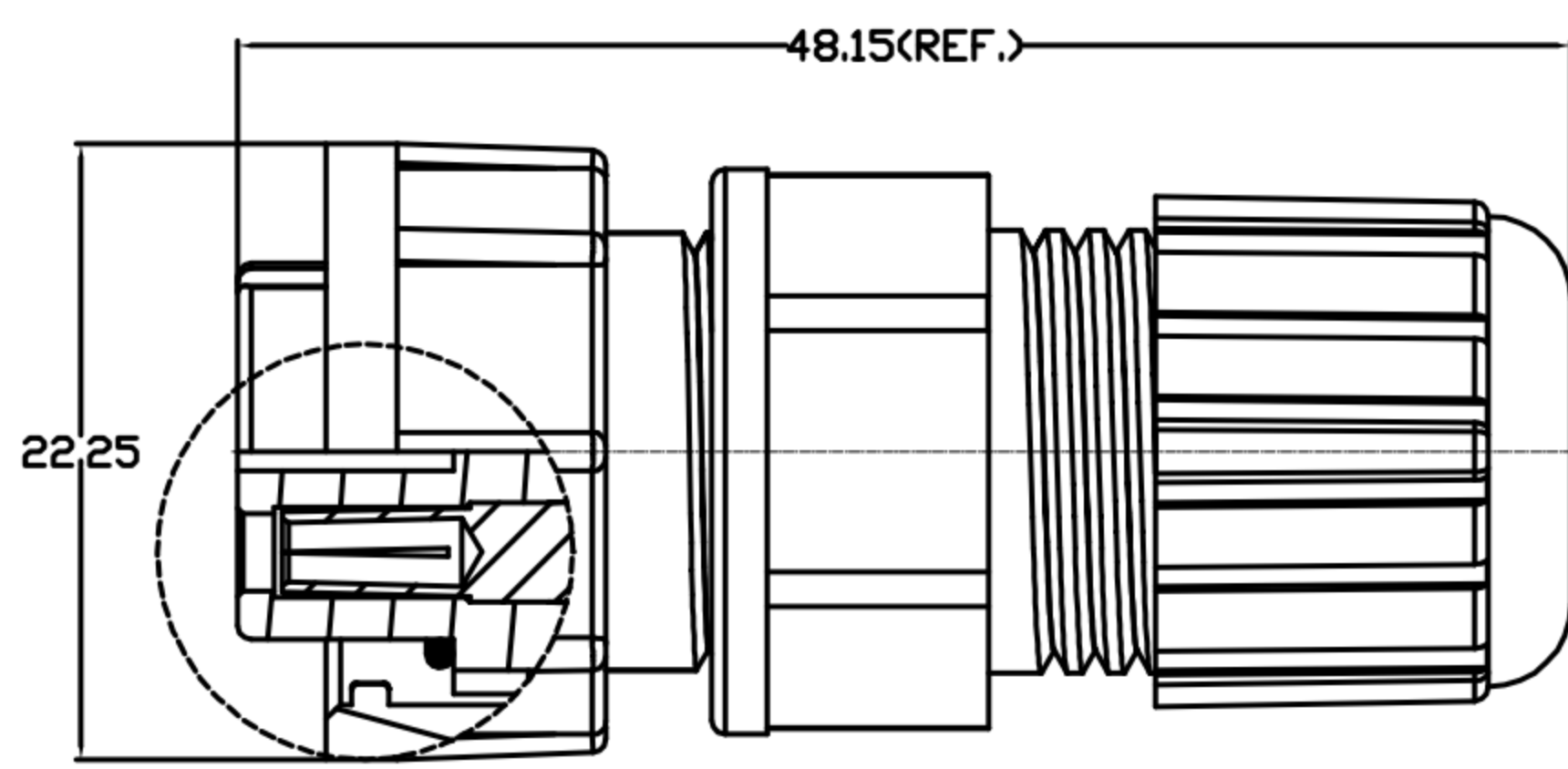
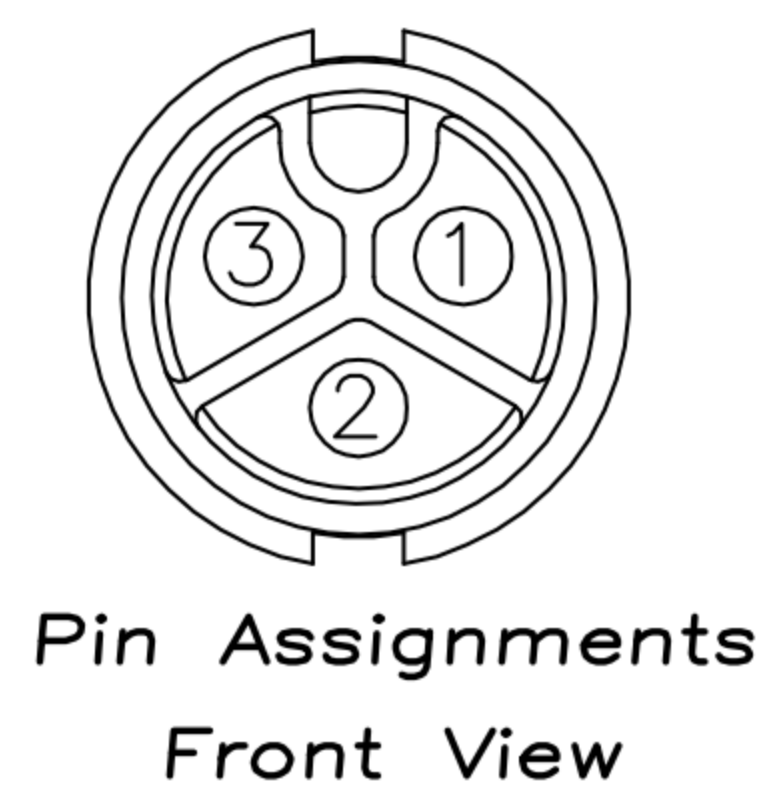
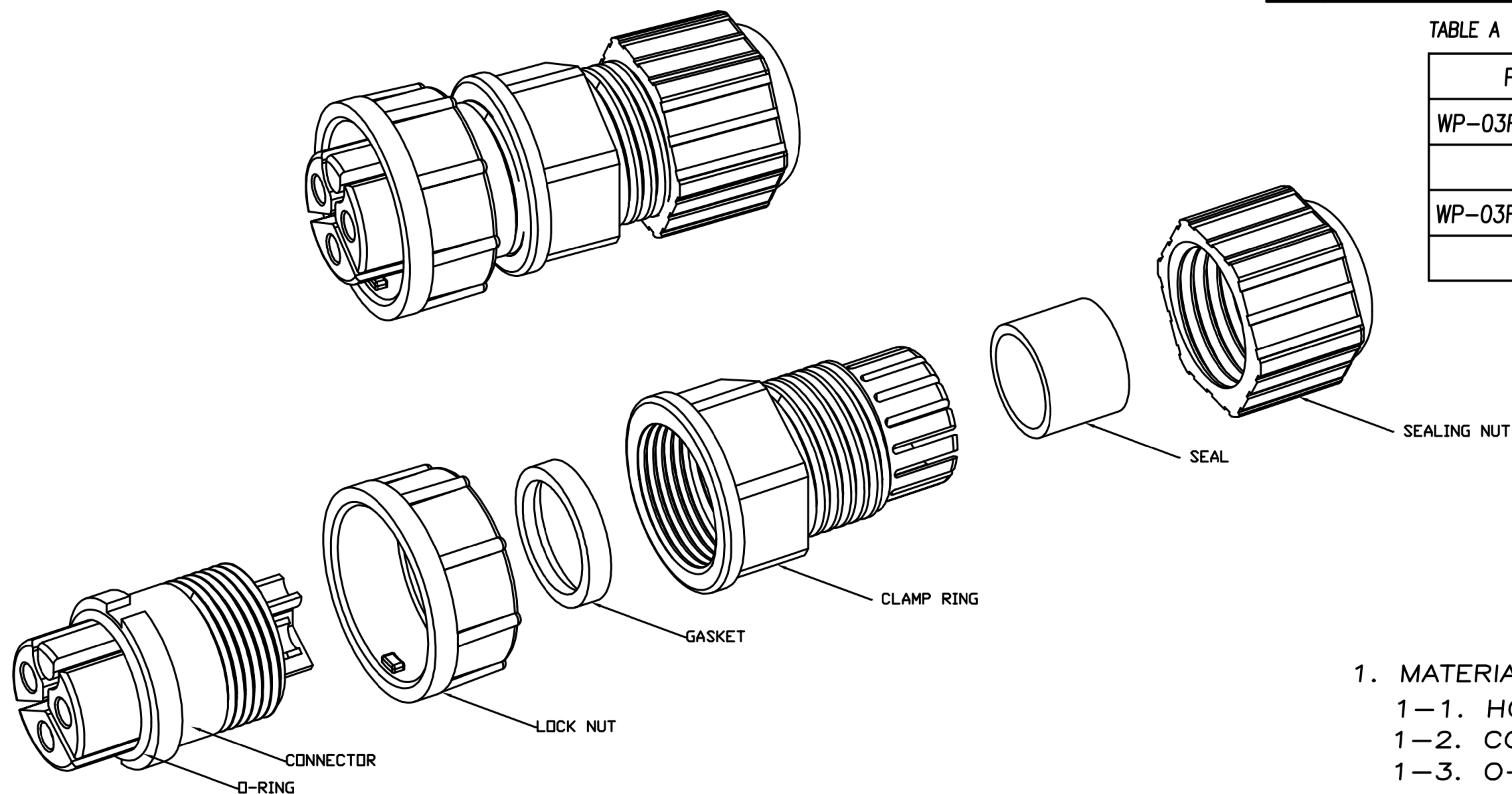

- MATERIAL :
  - 1-1. HOUSING : PA66
  - 1-2. CONTACT : BRASS
  - 1-3. O-RING : SILICONE
  - 1-4. LOCK NUT : PA66
  - 1-5. GASKET : SILICONE
  - 1-6. CLAMP RING : SEE TABLE A △C
  - 1-7. SEAL : SILICONE
  - 1-8. SEALING NUT : PA66
- FINISH :
  - 2-1. CONTACT : GOLD FLASH PLATED.
- ELECTRICAL SPECIFICATION :
  - 3-1. Rated current : 20A
  - 3-2. Rated Voltage : 250V
  - 3-3. Water proof : IP67
- Environmental :
  - 4-1. Operation Temperature : -40℃~105℃

DRAWN	Emily Suen	APP'D	Ku Chou	UNIT	mm	TOLERANCE		广东科斯达电子科技有限公司 GUANG DONG KE SI DA ELECTRONIC TECHNOLOGY CO., LTD.	TITLE	WP 3P FEMALE (FEMALE PIN) C SIZE ASSEMBLY TYPE(LOCK)			SHEET	1
CHK'D	Ku Chou			SCALE	1:1	.x ±0.20 .xx ±0.10 .xxx ±0.05 .xxxx ±0.03 ANGULAR ±1°			PART NO.	SEE TABLE A	DWG NO.	QC8632	VERSION	