

CUSTOMER DRAWING

REV.	DESCRIPTION	APPROVED BY	DATE	ECN NO.
△A	RELEASE	Ku Chou	08/01/19'	
△B				
△C				

TABLE A

P/N	MATERIAL(CLAMP RING)	CABLE ODφ
WP-03F2-125-11	PA66	φ8.6mm~φ9.6mm
	PA66	φ6.5mm~φ7.6mm
	PBT+PC, UL94V-0(F1)	φ8.6mm~φ9.6mm
	PBT+PC, UL94V-0(F1)	φ6.5mm~φ7.6mm

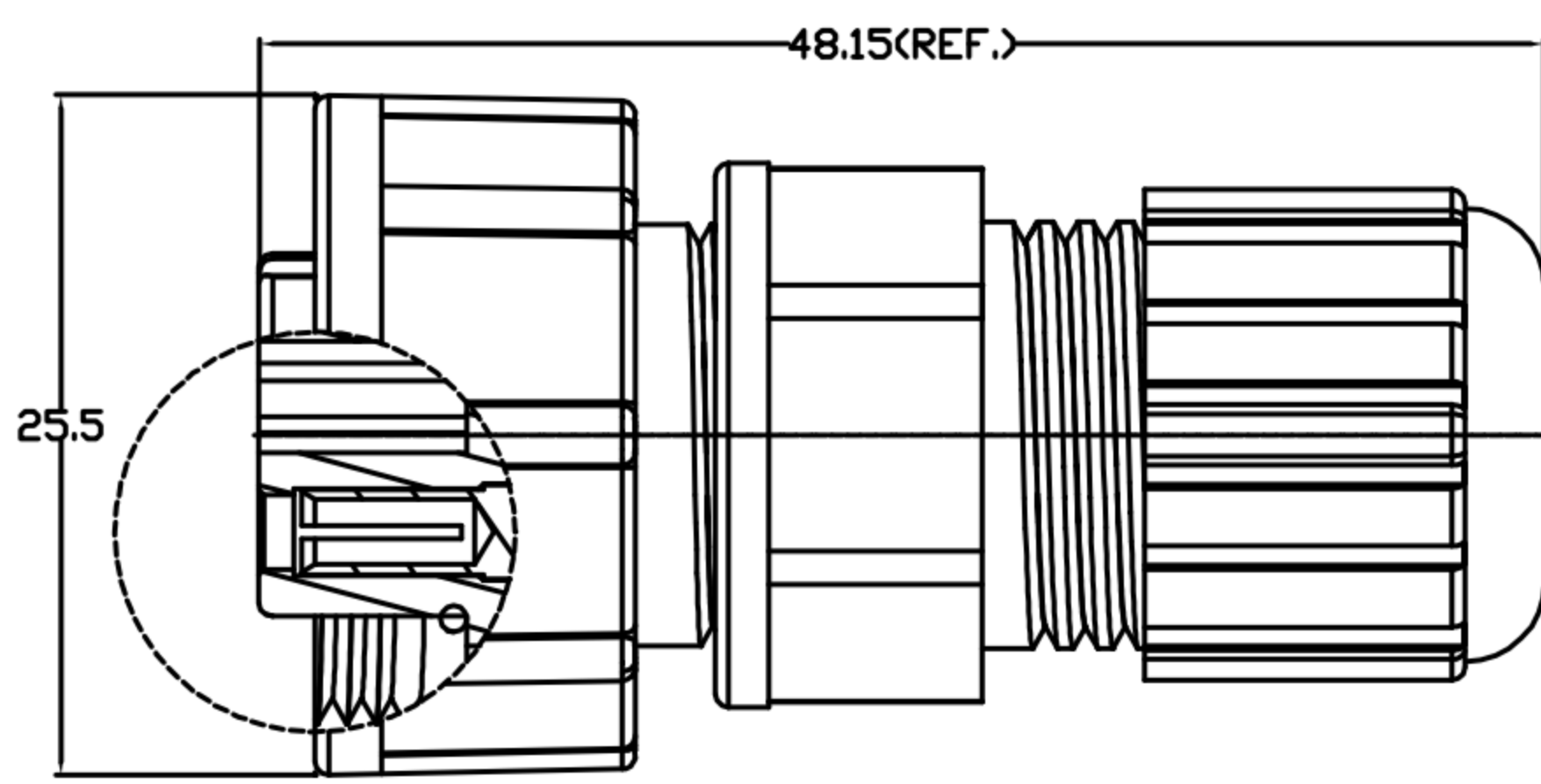
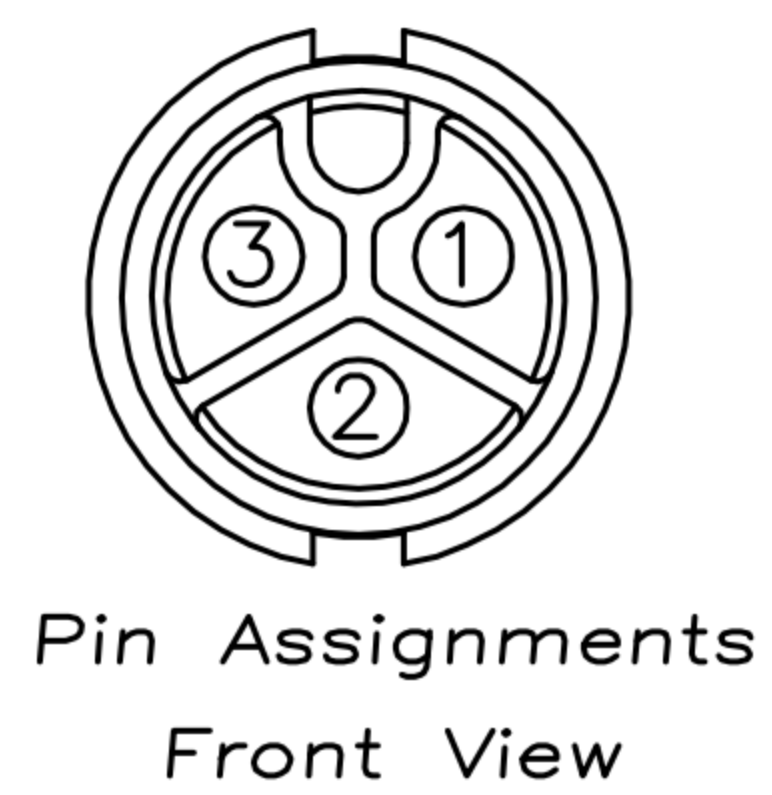
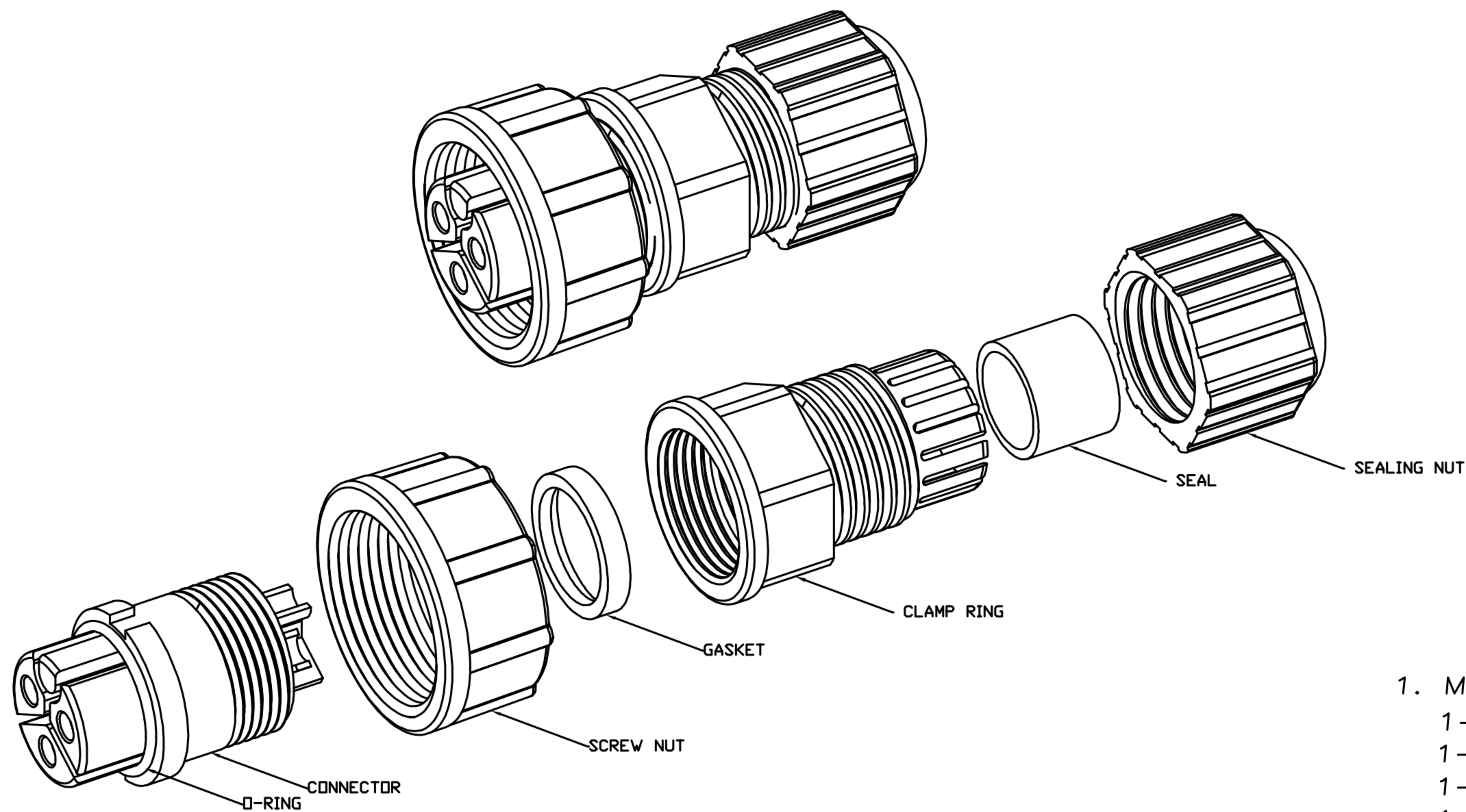

1. MATERIAL :
 - 1-1. HOUSING : PA66
 - 1-2. CONTACT : BRASS
 - 1-3. O-RING : SILICONE
 - 1-4. SCREW NUT : PA66
 - 1-5. GASKET : SILICONE
 - 1-6. CLAMP RING : SEE TABLE A
 - 1-7. SEAL : SILICONE
 - 1-8. SEALING NUT : PA66
2. FINISH :
 - 2-1. CONTACT : GOLD FLASH PLATED.
3. ELECTRICAL SPECIFICATION :
 - 3-1. Rated current : 20A
 - 3-2. Rated Voltage : 250V
 - 3-3. Water proof : IP67
4. Environmental :
 - 4-1. Operation Temperature : -40℃~105℃

DRAWN	Emily Suen	APP'D	Ku Chou	UNIT	mm	TOLERANCE		广东科斯达电子科技有限公司 GUANG DONG KE SI DA ELECTRONIC TECHNOLOGY CO., LTD.	TITLE	WP 3P FEMALE (FEMALE PIN) C SIZE ASSEMBLY TYPE(SCREW)			SHEET	1
CHK'D	Ku Chou			SCALE	1:1	.x ±0.20 .xx ±0.10 .xxx ±0.05 .xxxx ±0.03 ANGULAR ±1°			PART NO.	SEE TABLE A	DWG NO.	QC9140	VERSION	