

CUSTOMER DRAWING

REV.	DESCRIPTION	APPROVED BY	DATE	ECN NO.
△A	RELEASE	Ku Chou	30/11/18'	
△B	CHANGE RATED VOLTAGE	Ku Chou	13/12/18'	
△C				

TABLE A

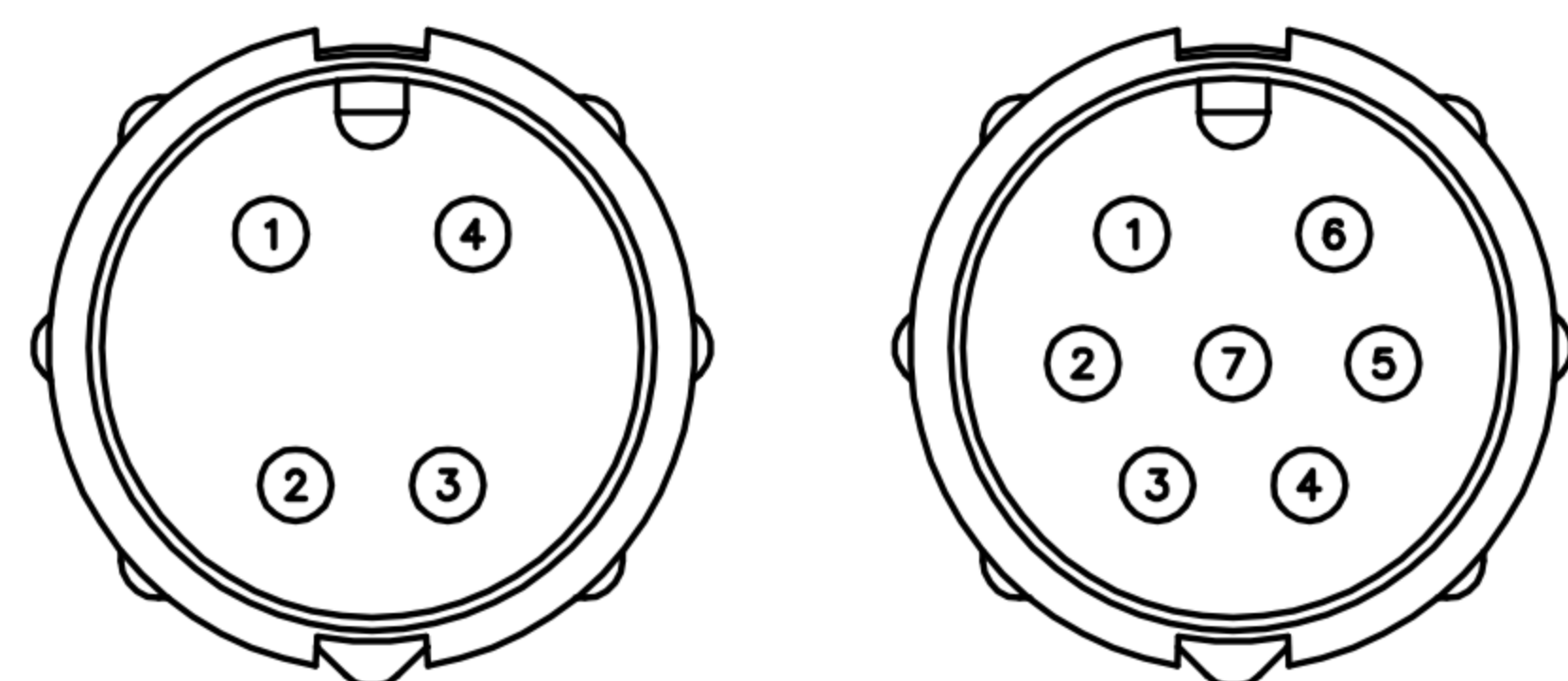

WP-04M2-165-11

7P

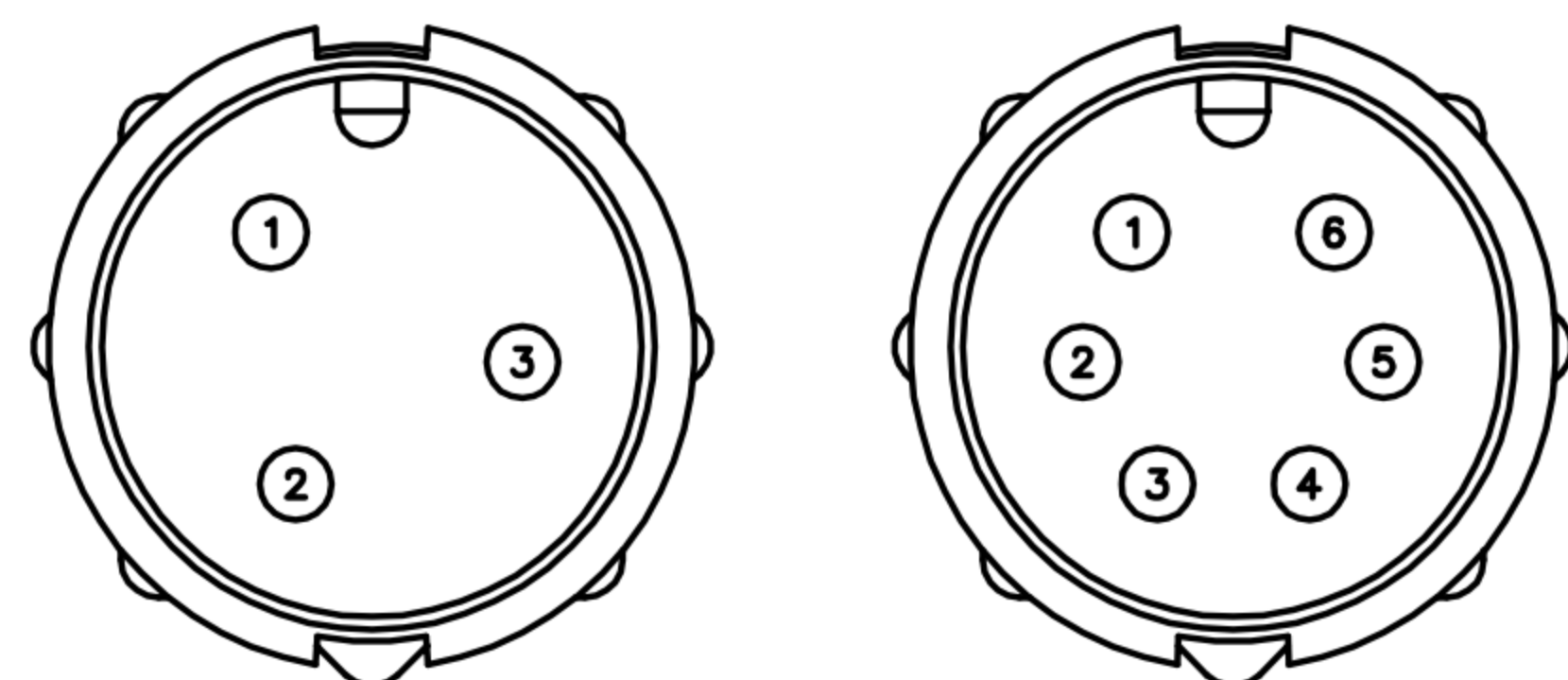

3P

6P

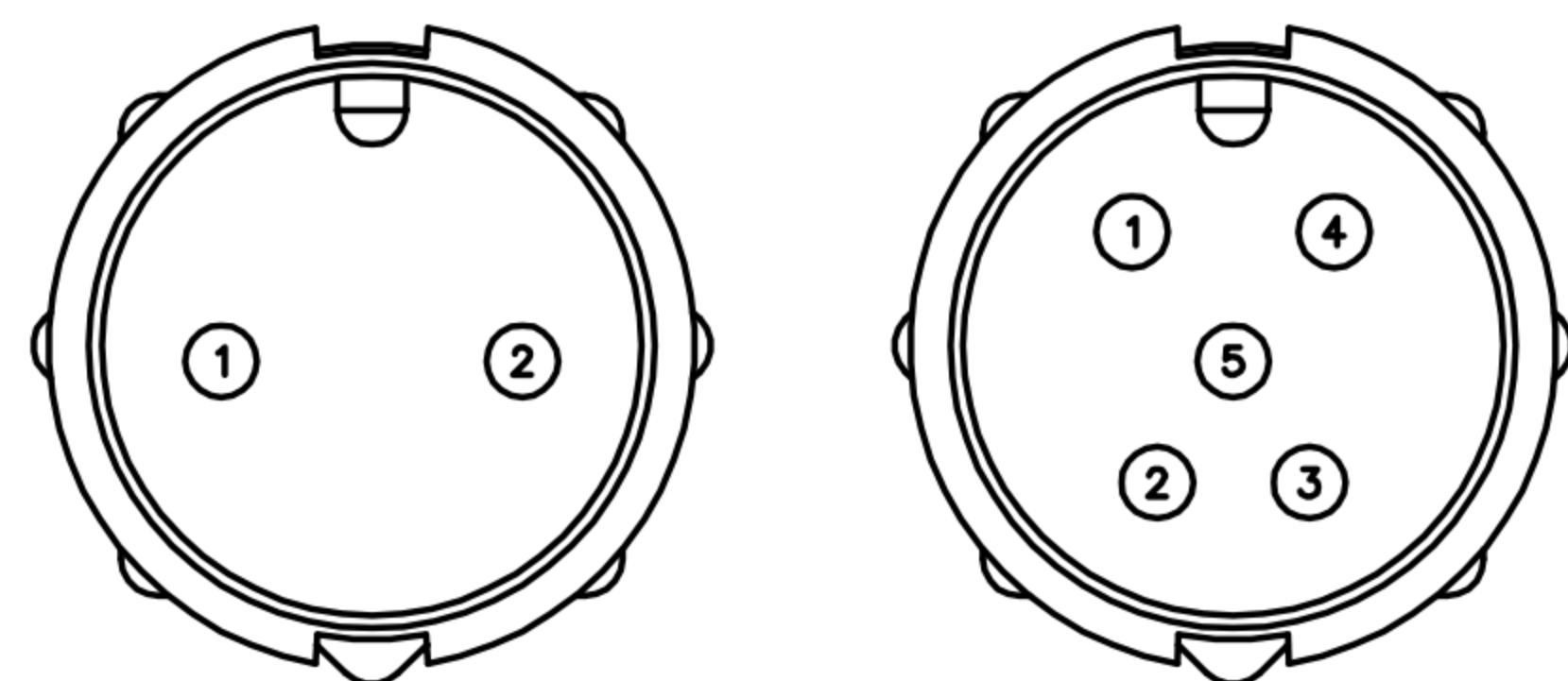

2P

WP-05M2-132-11

Pin Assignments
Front View

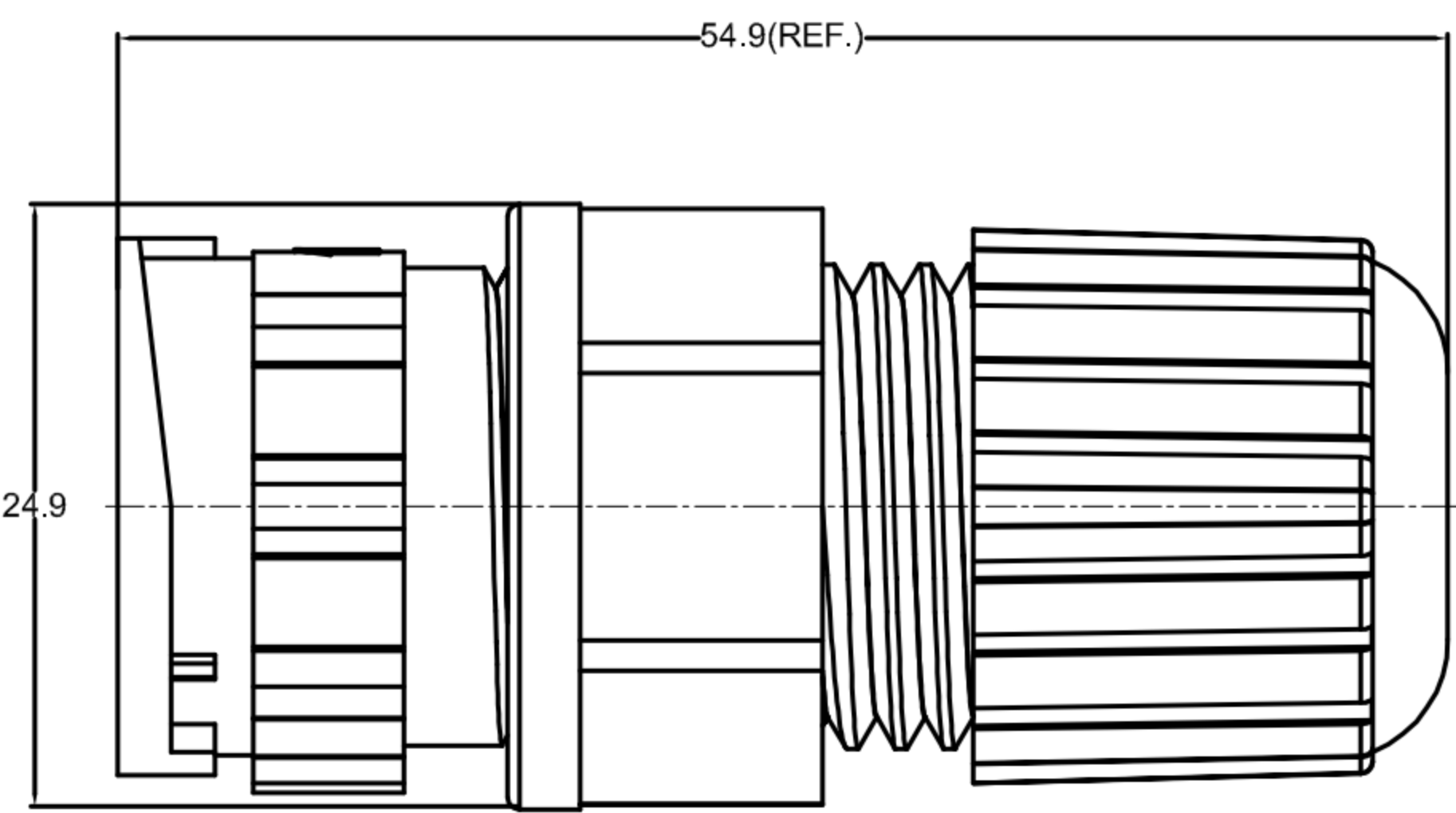
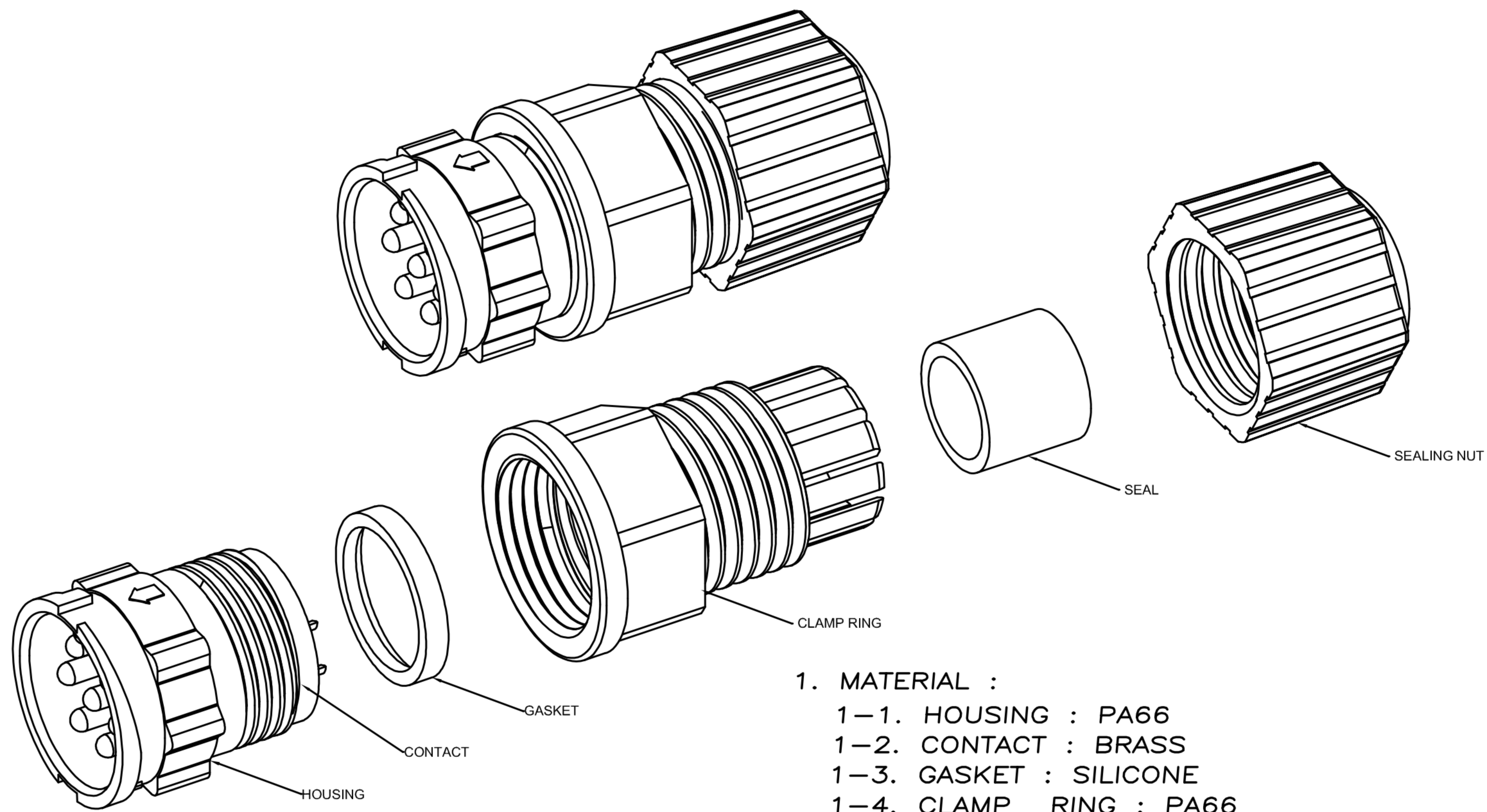
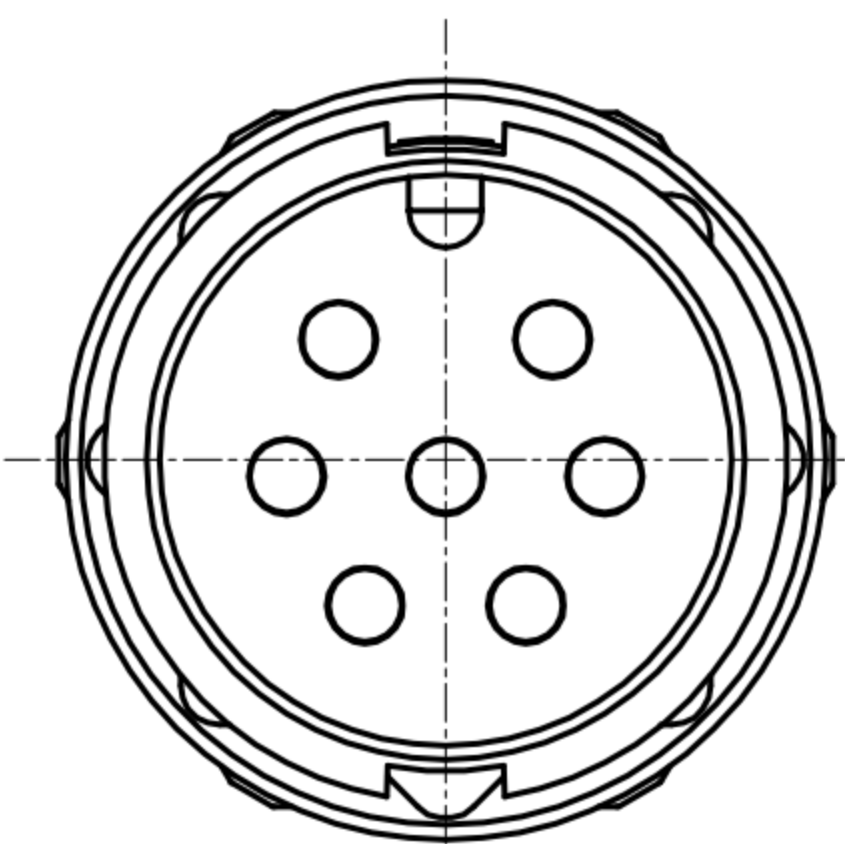

- MATERIAL :
 - 1-1. HOUSING : PA66
 - 1-2. CONTACT : BRASS
 - 1-3. GASKET : SILICONE
 - 1-4. CLAMP RING : PA66
 - 1-5 SEAL : SILICONE
SEAL FOR CABLE OD ϕ 5.5mm ~10.8mm
 - 1-6. SEALING NUT : PA66
- FINISH :
 - 2-1. CONTACT : GOLD FLASH PLATED.
- ELECTRICAL SPECIFICATION :
 - 3-1. Rated current : 20A
 - △3-2. Rated Voltage : 300V
 - 3-3. Water proof : IP67
- Environmental :
 - 4-1. Operation Temperature : -40 $^{\circ}$ C~105 $^{\circ}$ C

DRAWN	Emily Suen	APP'D	Ku Chou	UNIT	mm	TOLERANCE		广东科斯达电子科技有限公司 GUANG DONG KE SI DA ELECTRONIC TECHNOLOGY CO., LTD.	TITLE	WP M CONN. (M PIN) D SIZE ASSEMBLY TYPE(LOCK)-20A			SHEET	1
CHK'D	Ku Chou			SCALE	1:1	.x ± 0.20 .xx ± 0.10 .xxx ± 0.05 .xxxx ± 0.03 ANGULAR $\pm 1^{\circ}$			PART NO.	SEE TABLE A	DWG NO.	QC8837	VERSION	