

# CUSTOMER DRAWING

REV.	DESCRIPTION	APPROVED BY	DATE	ECN NO.
△A	RELEASE	Ku Chou	11/03/19'	
△B				
△C				

TABLE A

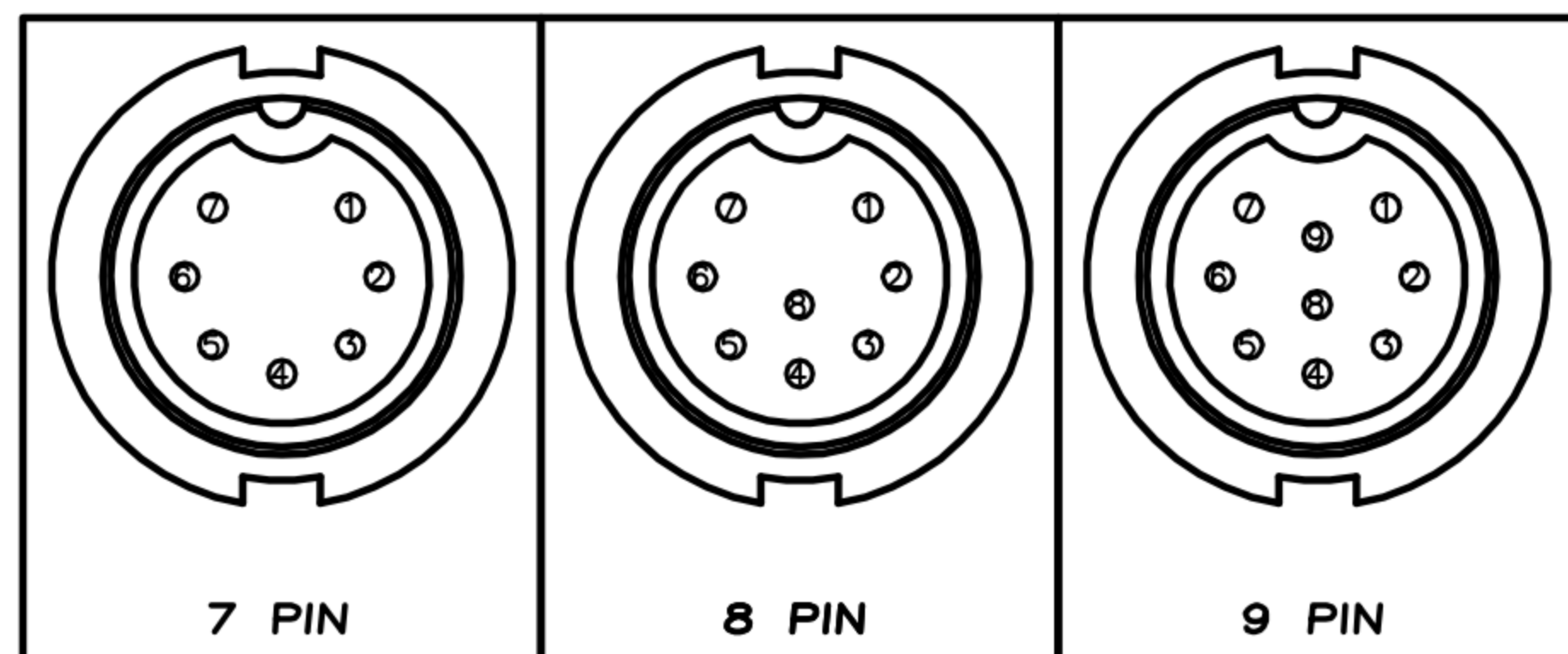

Pin Assignments  
Front View

TABLE A

P/N	MATERIAL(CLAMP RING)
WP-09M2-16-11	PBT+PC, UL94V-0(F1)
WP-09M2-15-11	PA66
WP-08M2-83-11	PA66
WP-07M2-14-11	PA66

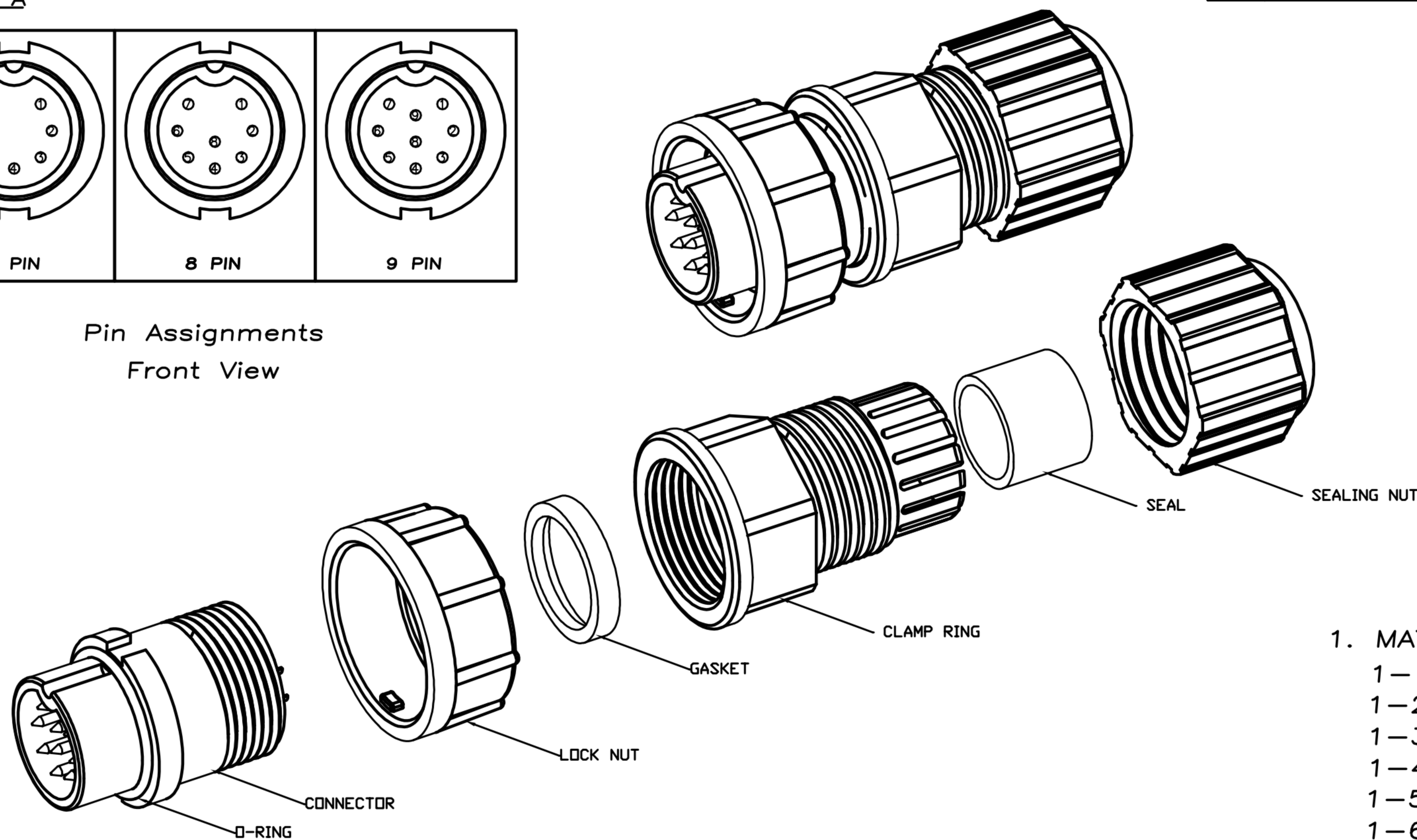

1. MATERIAL :

- 1-1. HOUSING : PA66
- 1-2. CONTACT : BRASS
- 1-3. O-RING : SILICONE
- 1-4. LOCK NUT : PA66
- 1-5. GASKET : SILICONE
- 1-6. CLAMP RING : SEE TABLE A  
CABLE ODφ φ6.5mm~φ7.6mm
- 1-7. SEAL : SILICONE
- 1-8. SEALING NUT : PA66

2. FINISH :

- 2-1. CONTACT : GOLD FLASH PLATED.

3. ELECTRICAL SPECIFICATION :

- 3-1. Rated current : 5A
- 3-2. Rated Voltage : 250V
- 3-3. Water proof : IP67

4. Environmental :

- 4-1. Operation Temperature : -40℃~105℃

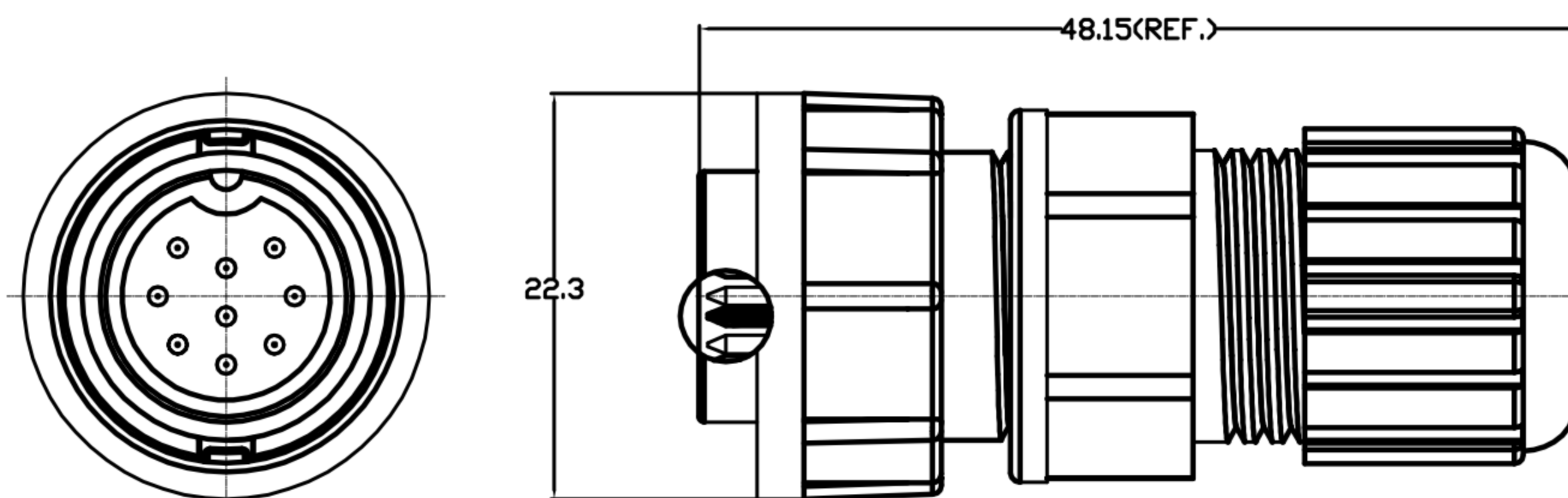

DRAW	Emily Suen	APP'D	Ku Chou	UNIT	mm	TOLERANCE		广东科斯达电子科技有限公司 GUANG DONG KE SI DA ELECTRONIC TECHNOLOGY CO., LTD.	TITLE	WP C SIZE F CONN (M PIN) ASSEMBLY TYPE(LOCK)			SHEET	
CHECK	Ku Chou			SCALE	1:1	.x ±0.20 .xx ±0.10 .xxx ±0.05 .xxxx ±0.03 ANGULAR ±1°			PART NO.	SEE TABLE A	DWG NO.	QC8975	VERSION	