

CUSTOMER DRAWING

REV.	DESCRIPTION	APPROVED BY	DATE	ECN NO.
A	RELEASE	Ku Chou	02/08/18'	
B	CHANGE CLAMP RING MATERIAL	Ku Chou	30/10/18'	
C				

TABLE A

P/N	CLAMP RING MATERIAL
RJ-08M2-01-01	PA66
RJ-08M2-03-01	PBT+PC, UL94V-0(F1)

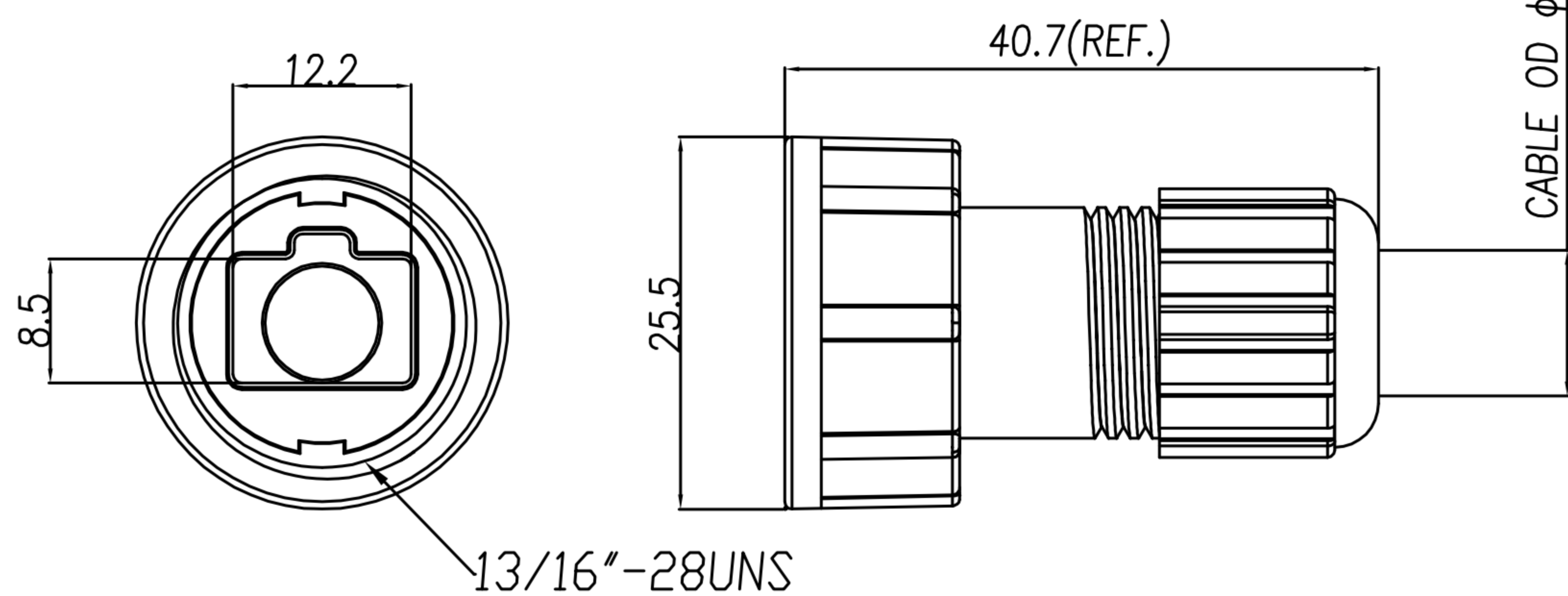
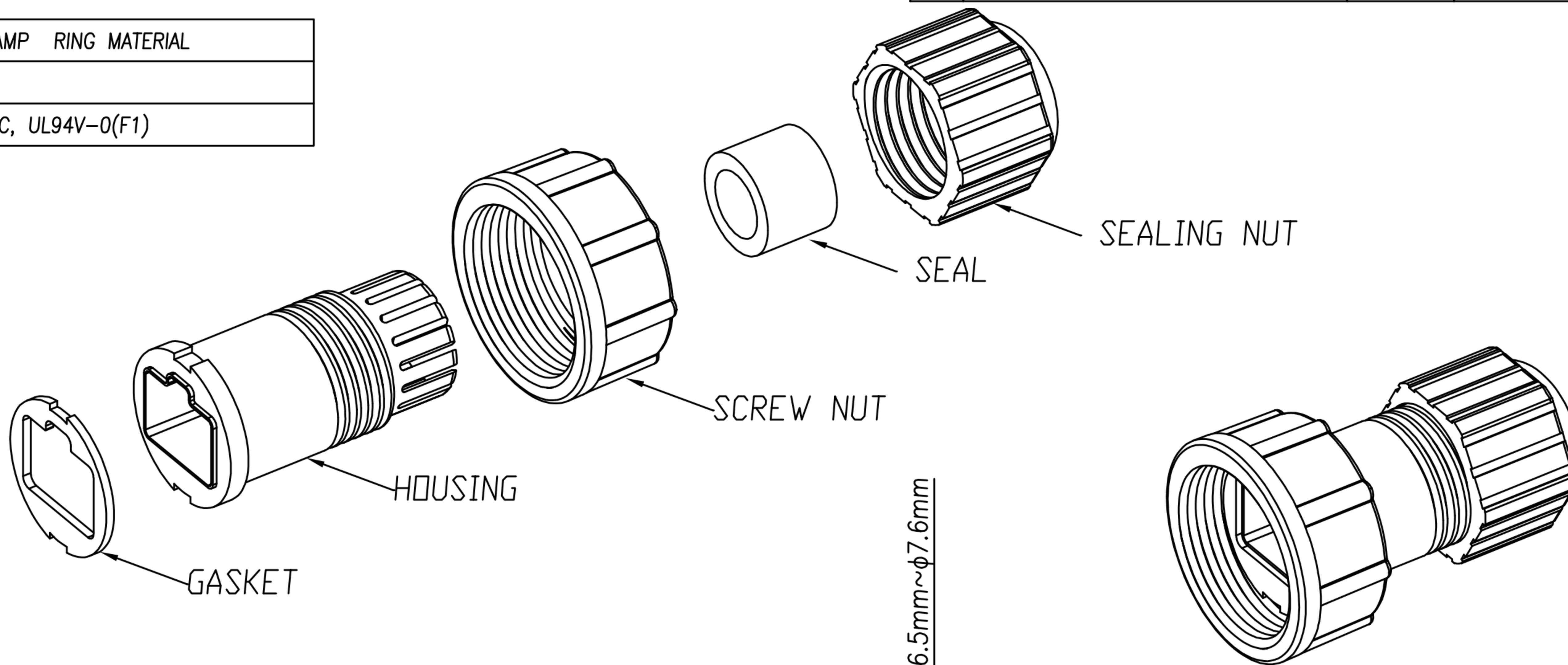

1. MATERIAL :
- 1-1. GASKET : SILICONE
 - 1-2. CLAMP RING : SEE TABLE A
 - 1-3. SCREW NUT : PA66
 - 1-4. SEAL : SILICONE
 - 1-5. SEALING NUT : PA66

DRAWN	Emily Suen	APP'D	Ku Chou	UNIT	mm	TOLERANCE		TITLE	13/16"-28UNS RJ45 ASSEMBLY TYPE			SHEET	
CHK'D	Ku Chou			SCALE	1:1	.x ±0.20 .xx ±0.10 .xxx ±0.05 .xxxx ±0.03 ANGULAR ±1°		PART NO.	SEE TABLE A	DWG NO.	QC8655	VERSION	

广东科斯达电子科技有限公司
 GUANG DONG KE SI DA ELECTRONIC TECHNOLOGY CO., LTD.