

CUSTOMER DRAWING

REV.	DESCRIPTION	APPVL. BY	DATE	ECN NO.
A	RELEASE	Yeh Chou	04/19/19'	
B				
C				

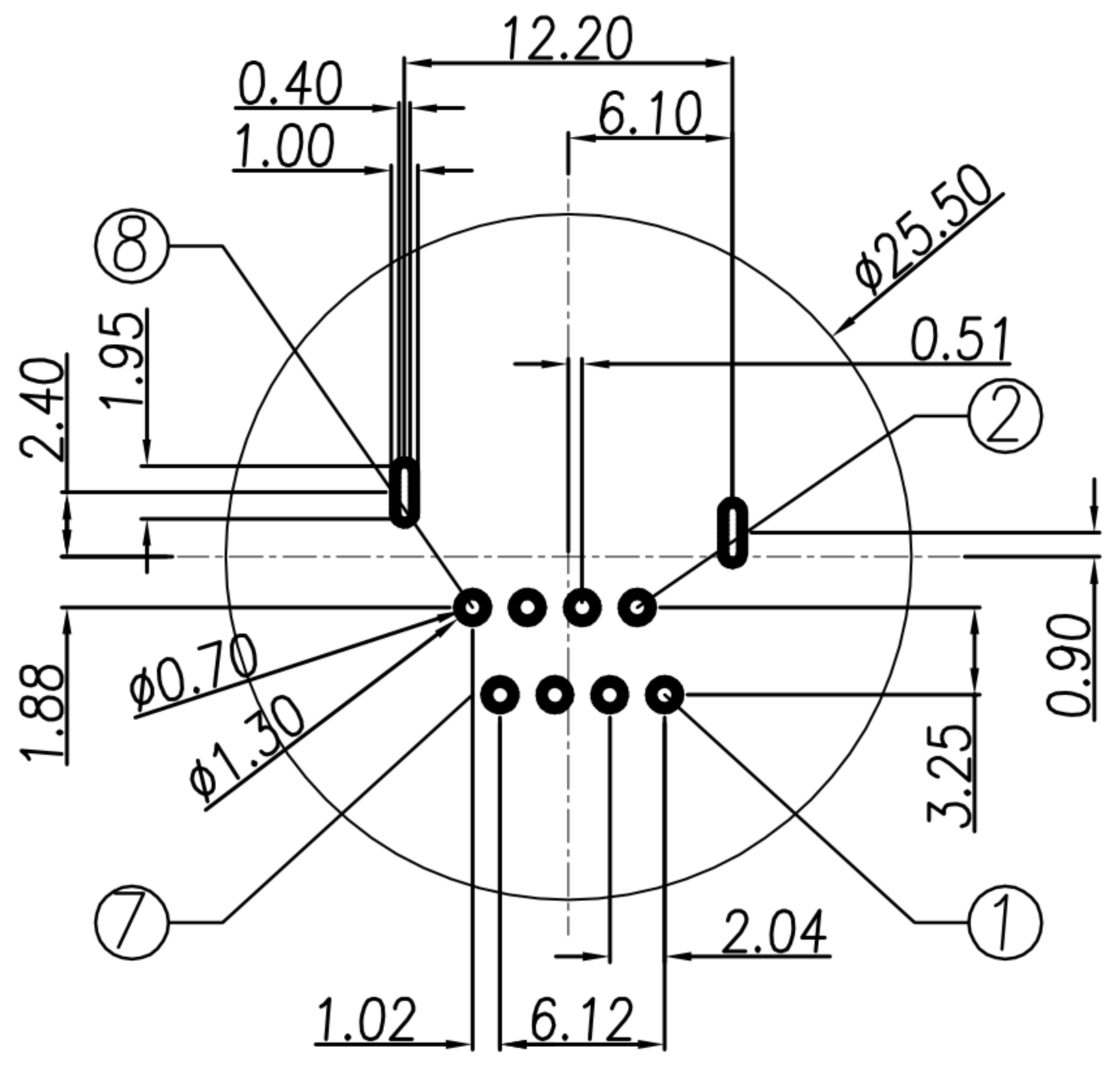

P.C.B LAYOUT (Top view)

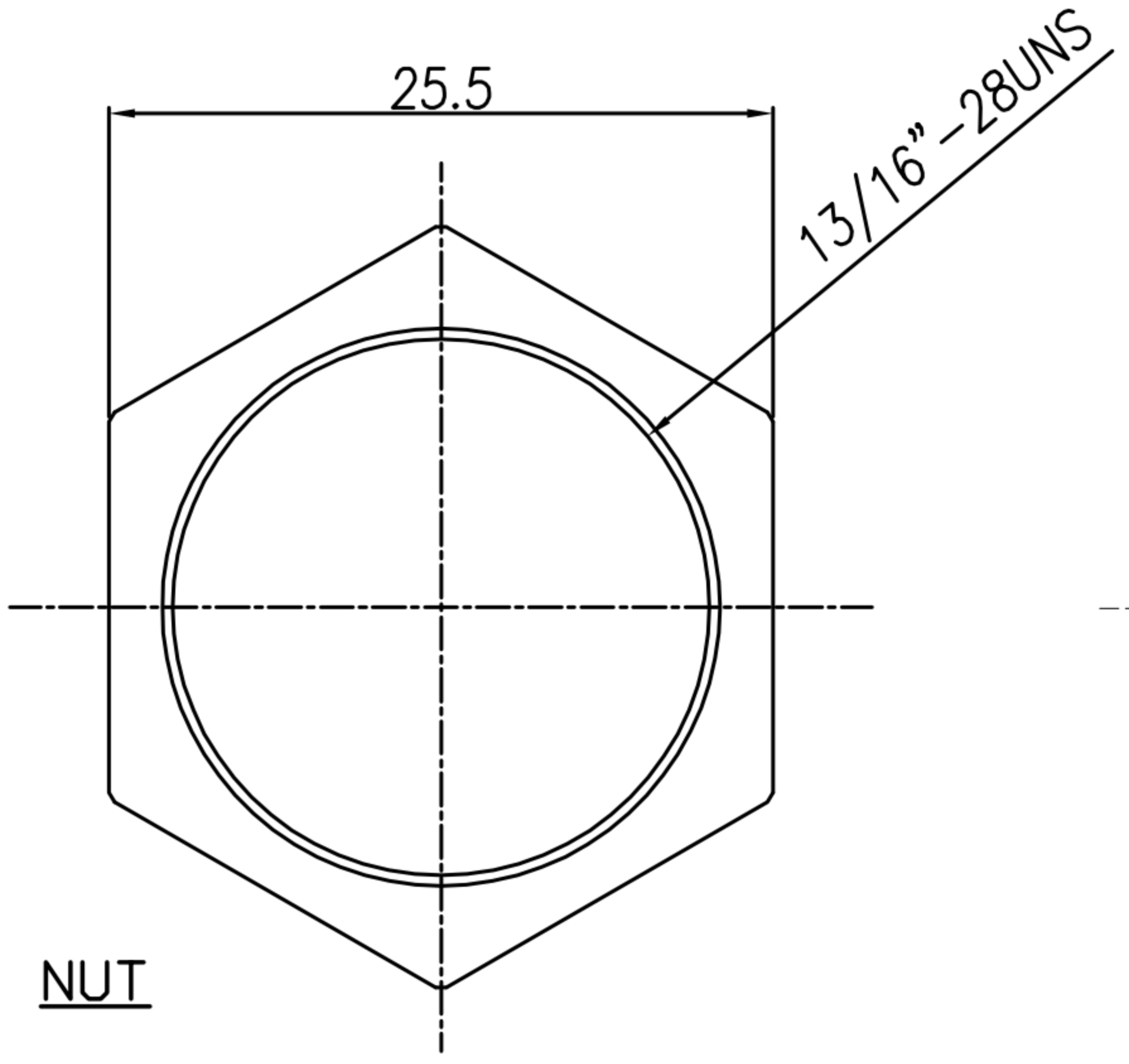
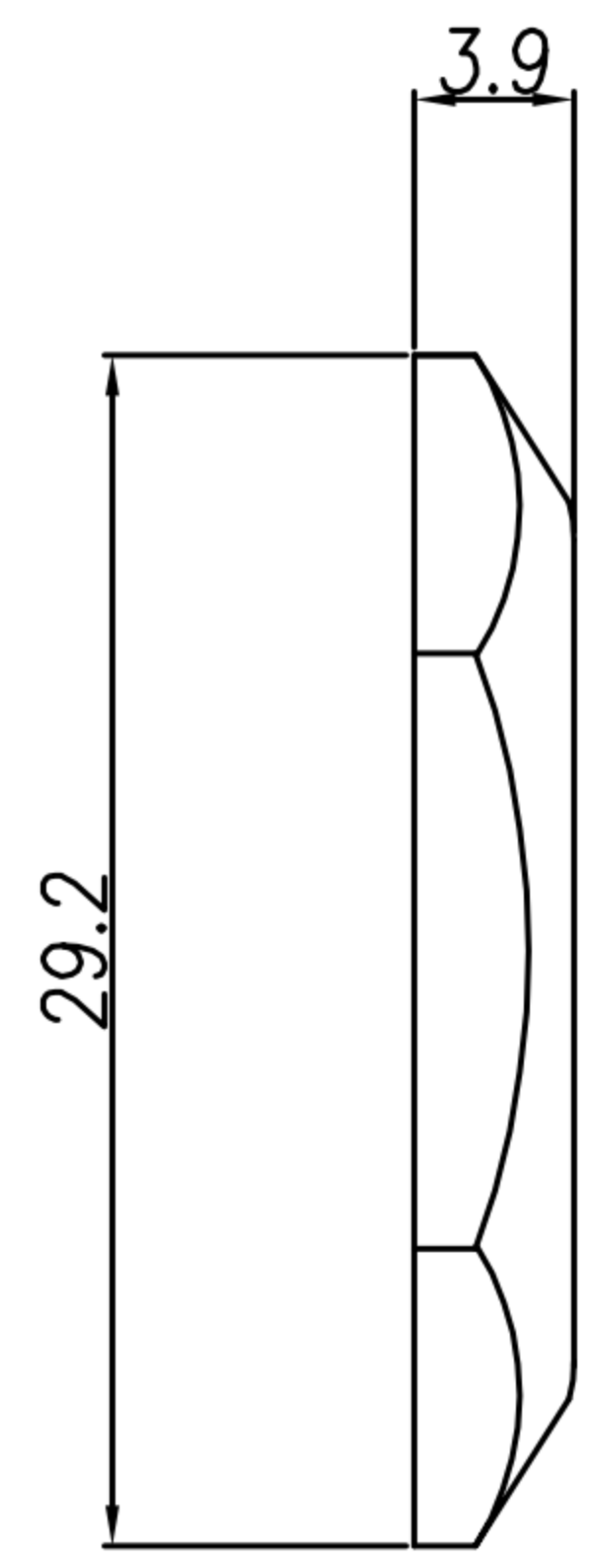
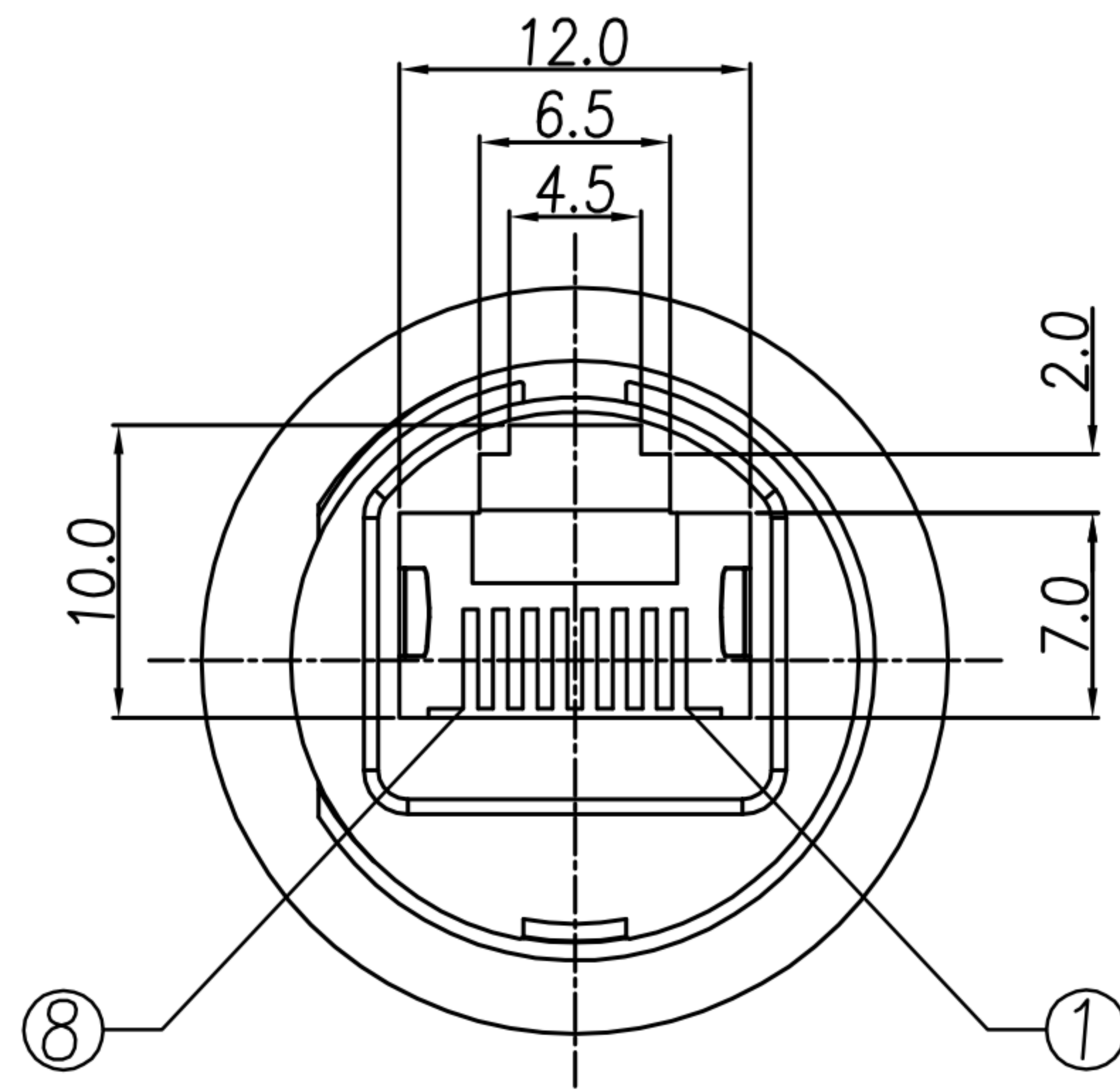
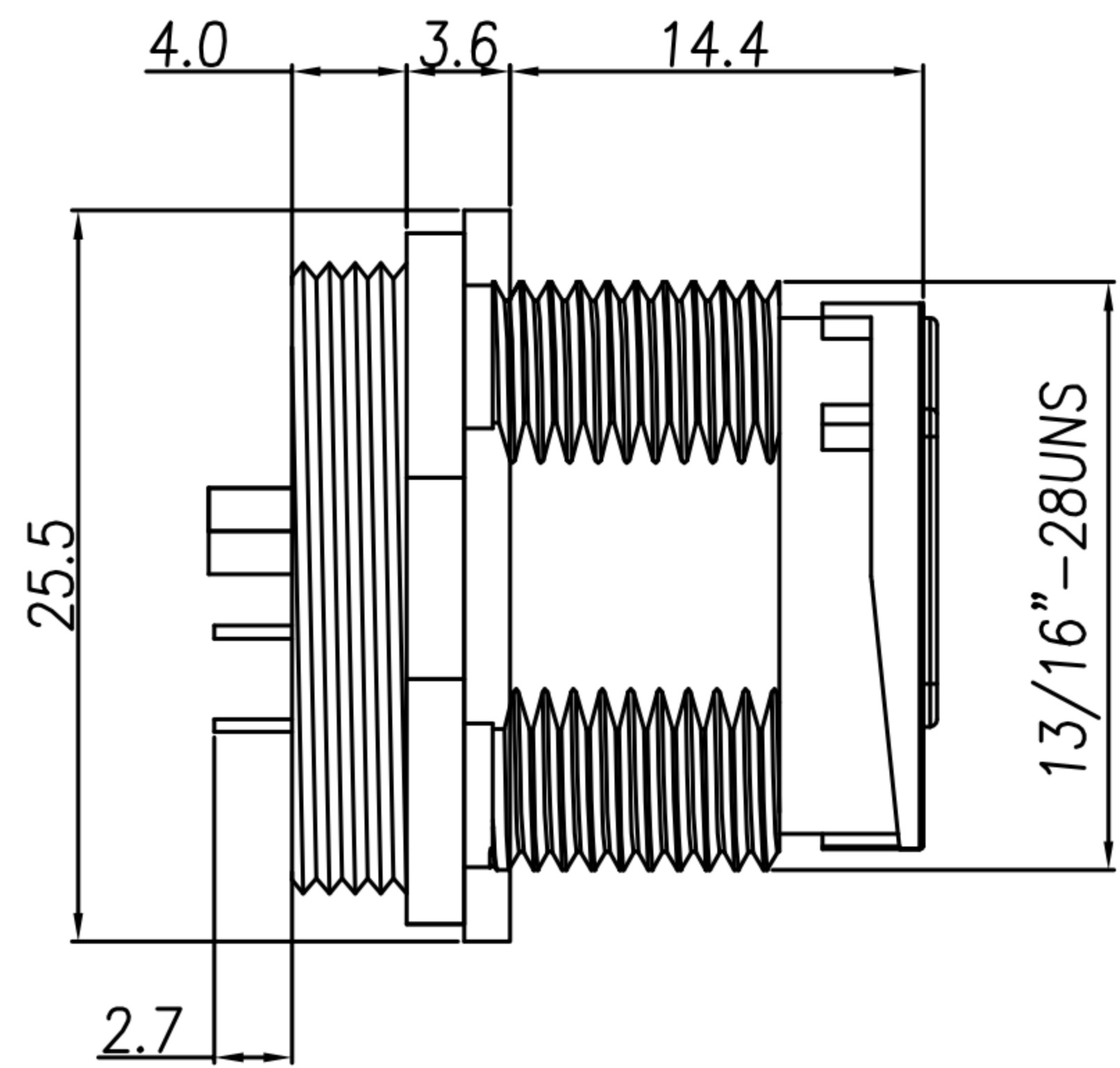

NUT

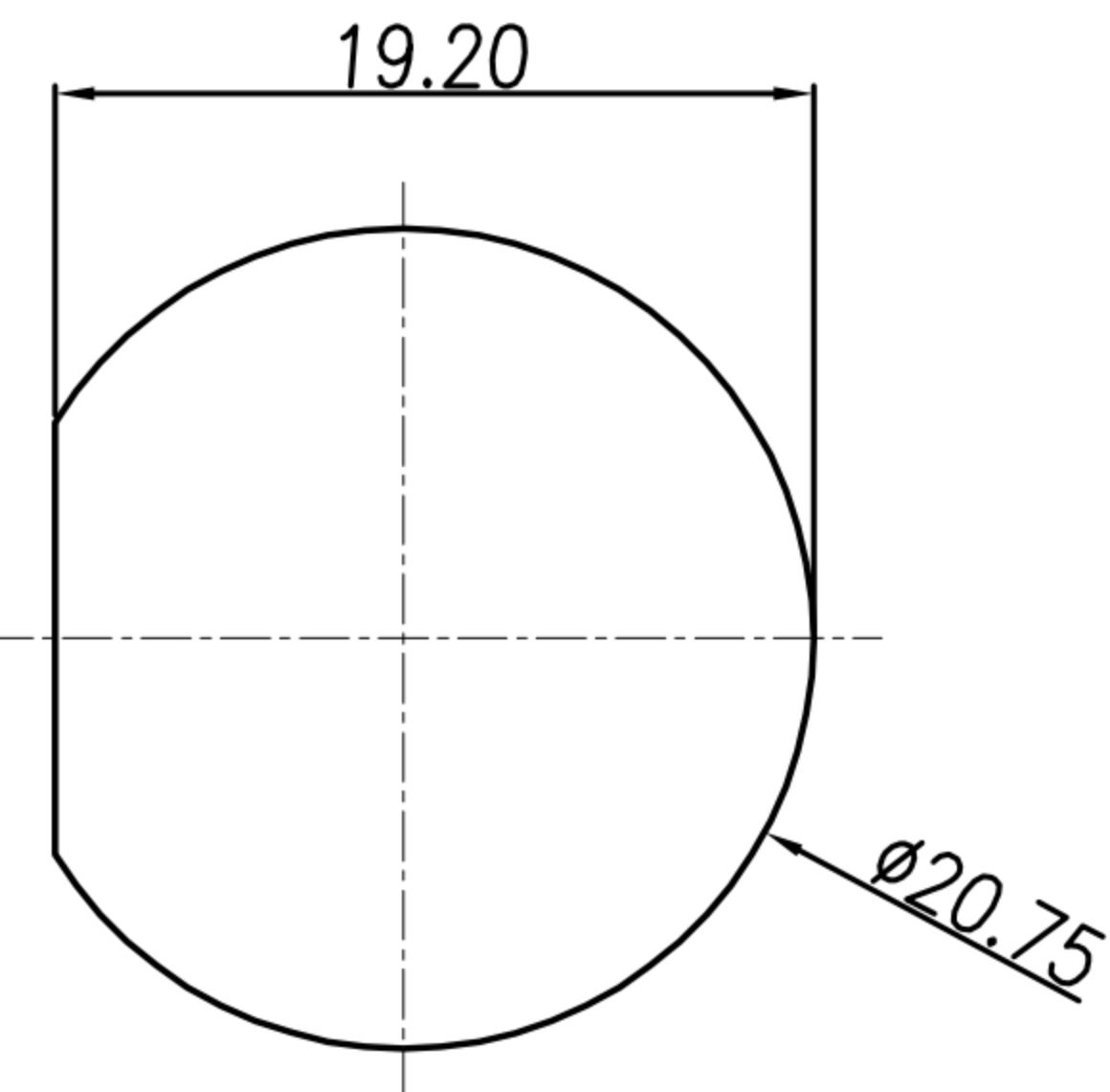

PANEL CUT-OUT

- MATERIAL :
 - 1-1. HOUSING : PBT UL94V-0 ; COLOR : BLACK.
 - 1-2. CONTACT : PHOSPHOR BRONZE
 - 1-3. SHELL : PA66 UL94V-0 ; COLOR : BLACK.
 - 1-4. GROUND : SUS 301
 - 1-5. GASKET : SILICONE ; COLOR : BLACK.
 - 1-6. NUT : PA66
- FINISH :
 - 2-1. CONTACT : GOLD FLASH PLATED
 - 2-2. GROUND : NICKEL PLATED.
- ELECTRICAL SPECIFICATION :
 - 3-1. Rated current : 2A
 - 3-2. Rated voltage : 250V
 - 3-3. Water proof : IPX7
- Environmental :
 - 4-1. Operation Temperature : -40°C~85°C

DRAW	Ku Chou	APPVL	Fido Weng	UNIT	mm	TOLERANCE			TITLE	防水RJ45 8PIN(F)(快锁式)			SHEET	
CHECK	Emily Suen			SCALE	1:1				PART NO.	RJ-08F2-12-01	DWG NO.	QC9087	VERSION	