

CUSTOMER DRAWING

REV.	DESCRIPTION	APPROVED BY	DATE	ECN NO.
A	RELEASE	Ku Chou	12/04/18*	
B				
C				

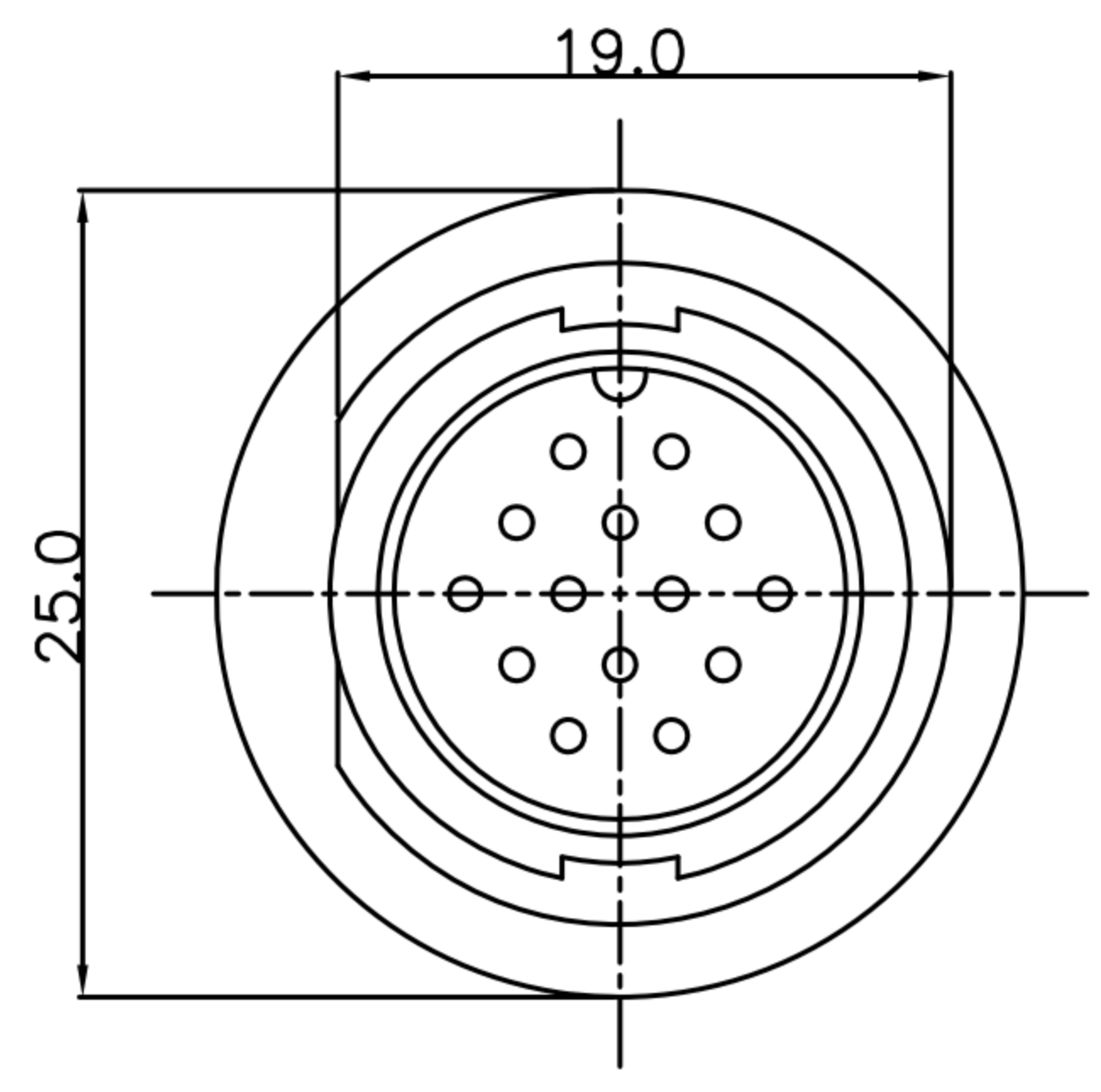
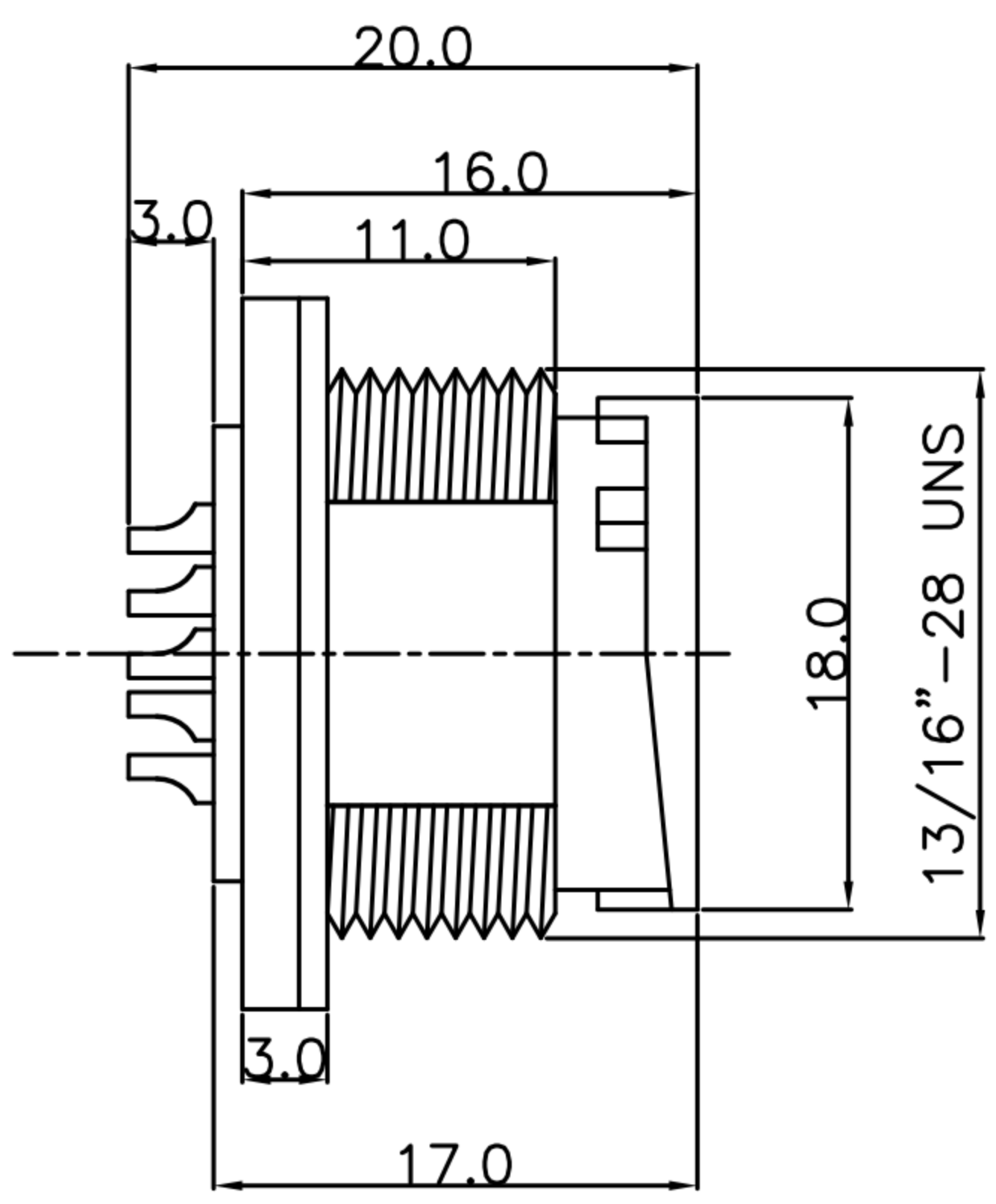

- MATERIAL :
 - 1-1. HOUSING : PA66
 - 1-2. CONTACT : BRASS
 - 1-3. GASKET : SILICONE
 - 1-4. HEX NUT : PA66
- FINISH :
 - 2-1. CONTACT : GOLD FLASH PLATED.
- ELECTRICAL SPECIFICATION :
 - 3-1. Rated current : 5A
 - 3-2. Rated Voltage : 250V
 - 3-3. Water proof : IP67
- Environmental :
 - 4-1. Operation Temperature : -40℃~105℃

TABLE A

07 PIN WP-07M2-22-11	08 PIN WP-08M2-115-11	09 PIN WP-09M2-20-11
10 PIN WP-10M2-18-11	12 PIN WP-12M2-30-11	14 PIN WP-14M2-01-11

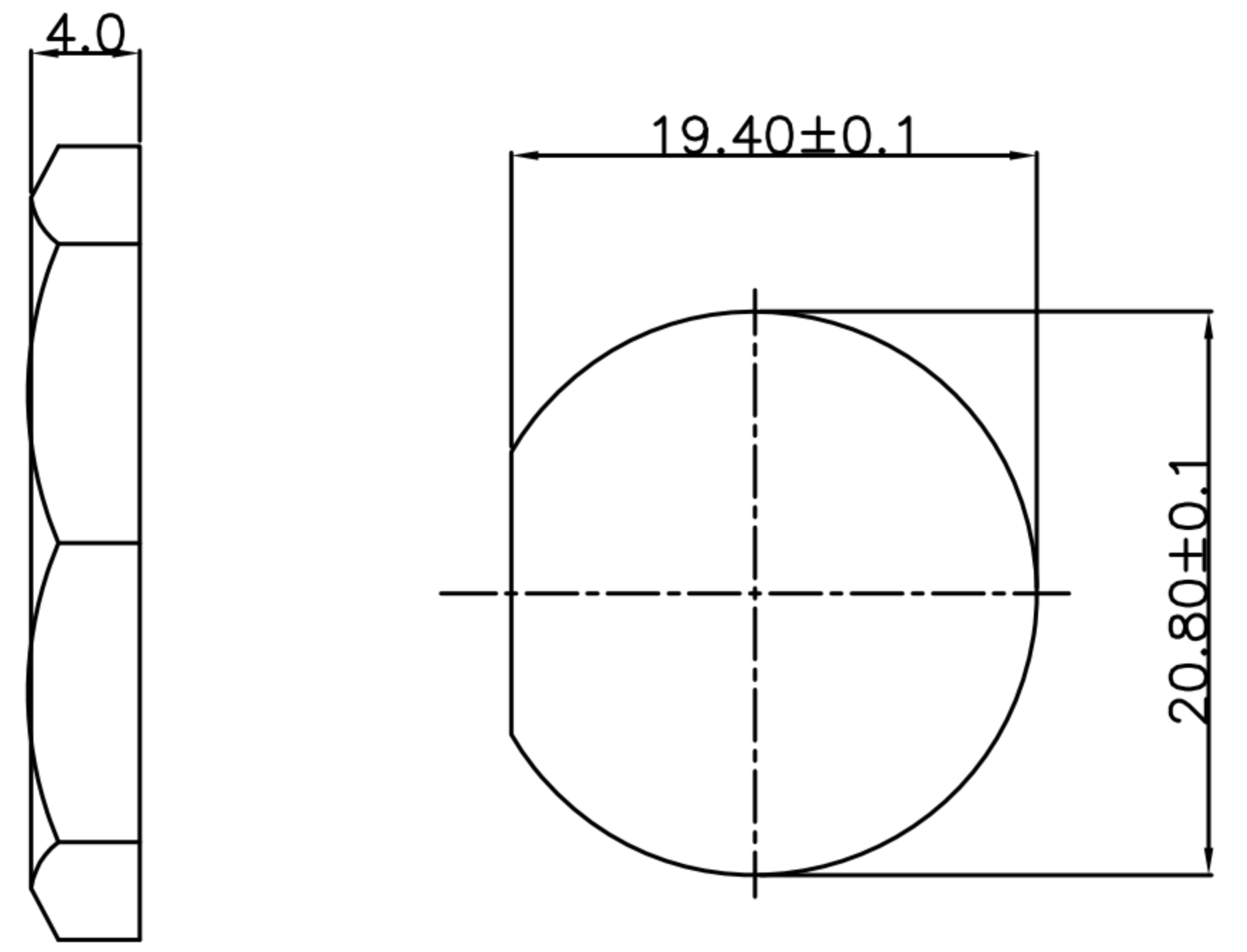
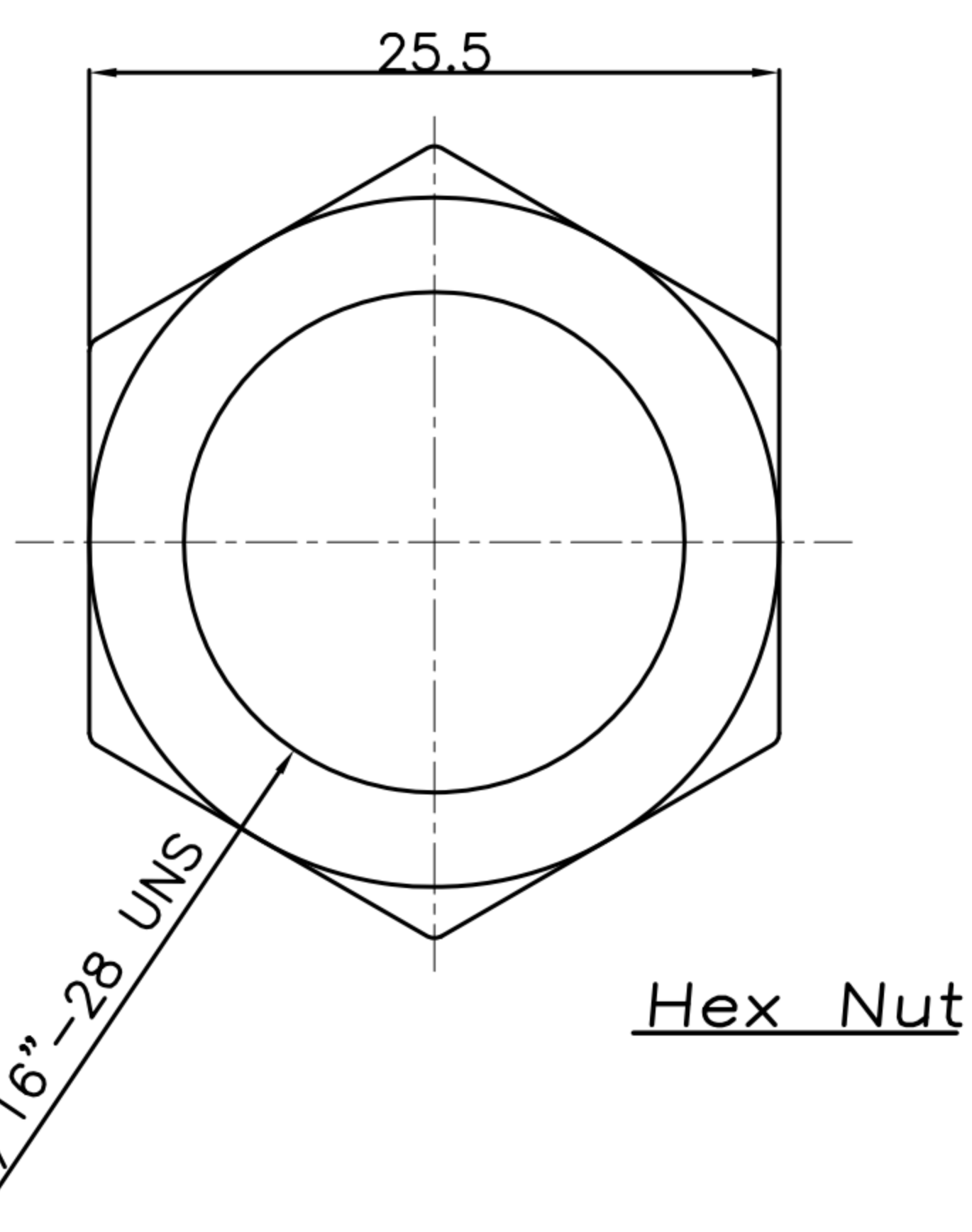

DRAWN	Emily Suen	APP'D	Ku Chou	UNIT	mm	TOLERANCE		广东科斯达电子科技有限公司 GUANG DONG KE SI DA ELECTRONIC TECHNOLOGY CO., LTD.	TITLE	WP C Size(M) Front Lock Solder Type(Lock Bayonet)			SHEET	1
CHK'D	Ku Chou			SCALE	1:1				PART NO.	SEE TABLE A	DWG NO.	QC8263	VERSION	