

CUSTOMER DRAWING

TABLE A

REV.	DESCRIPTION	APPROVED BY	DATE	ECN NO.
A	RELEASE	KU Chou	22/04/20*	
B				
C				
D				

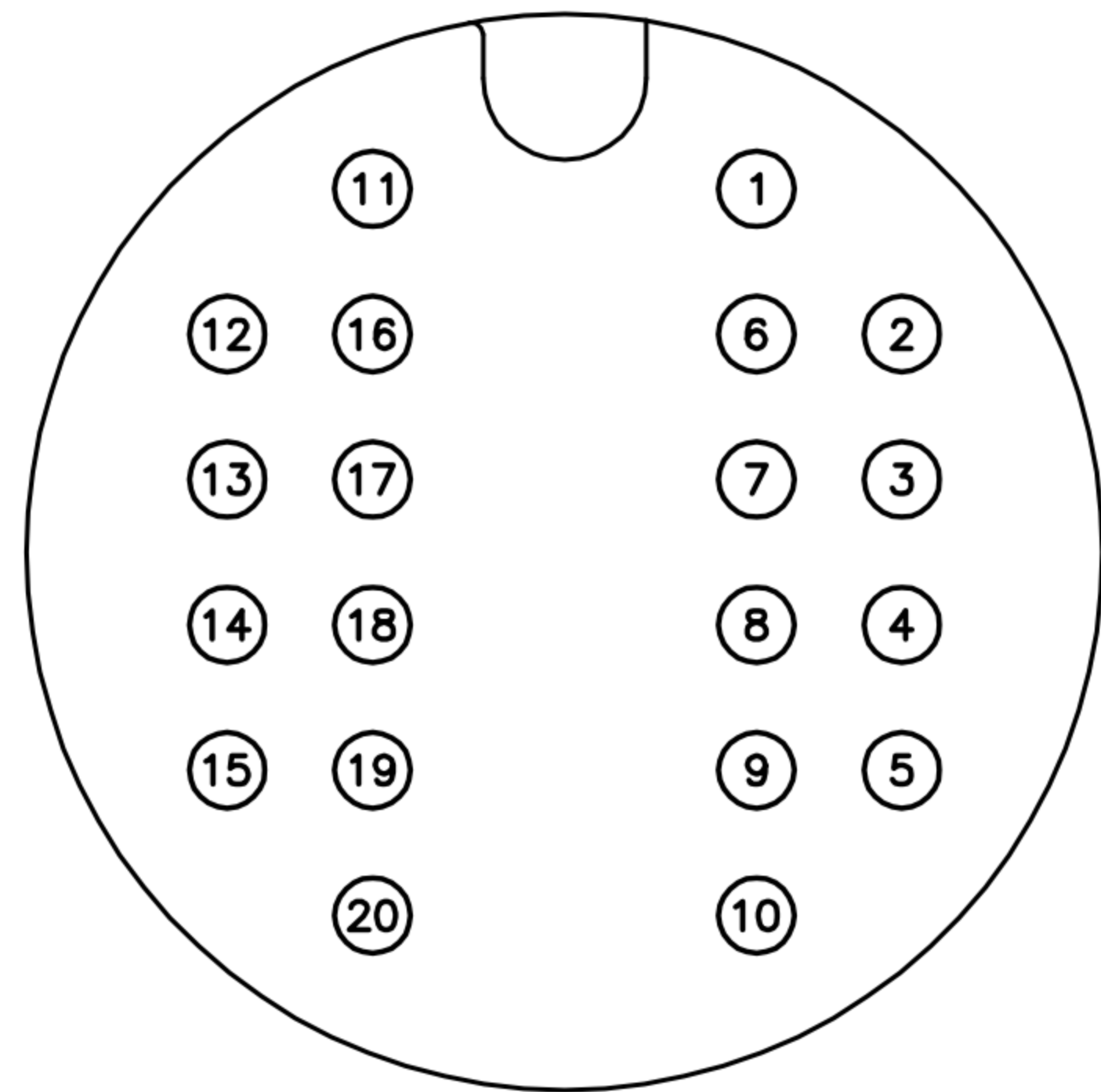

20P
WP-20F2-04-11

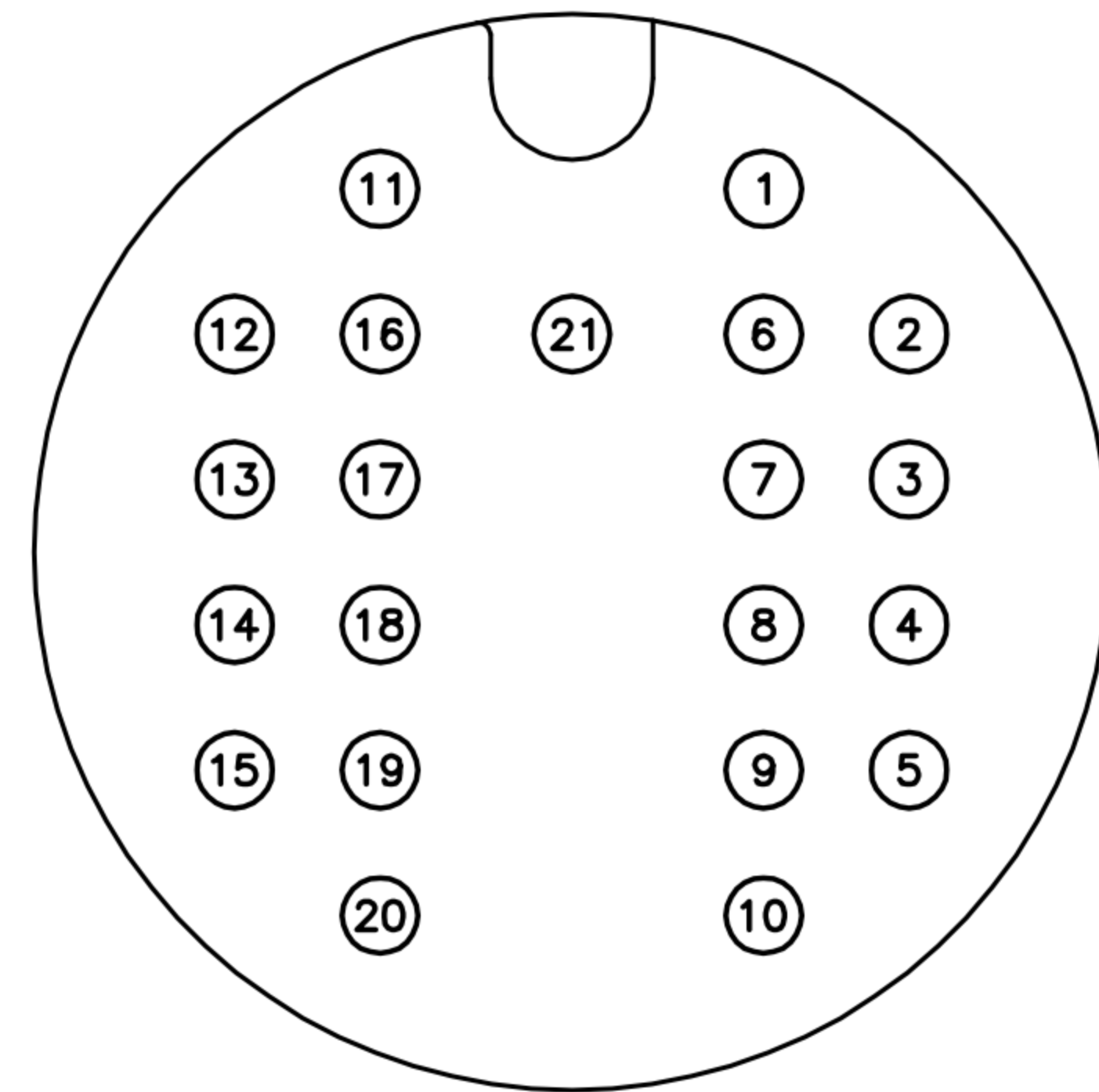

21P
WP-21F2-02-11

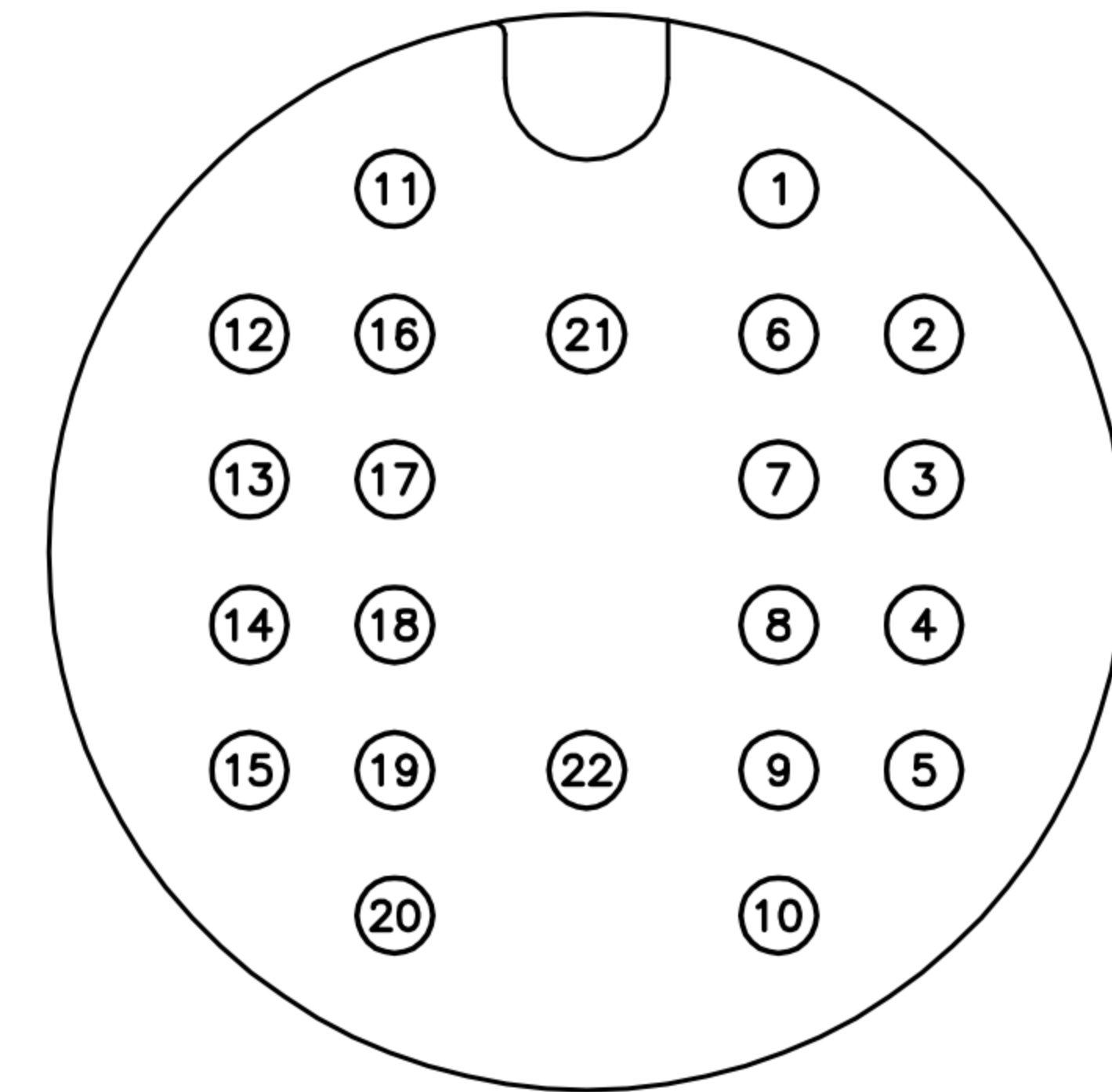

22P
WP-22F2-02-11

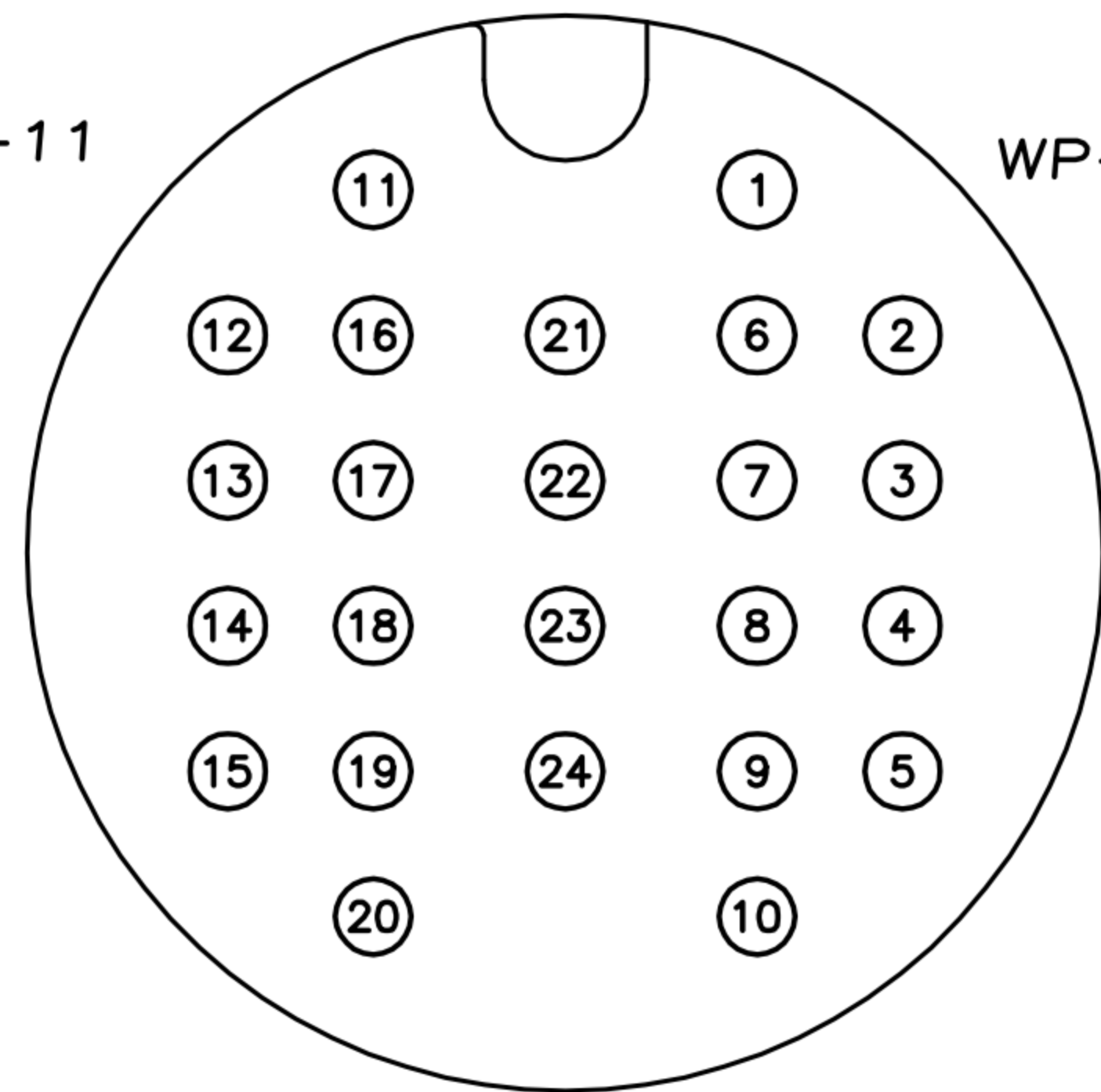

24P
WP-24F2-02-11

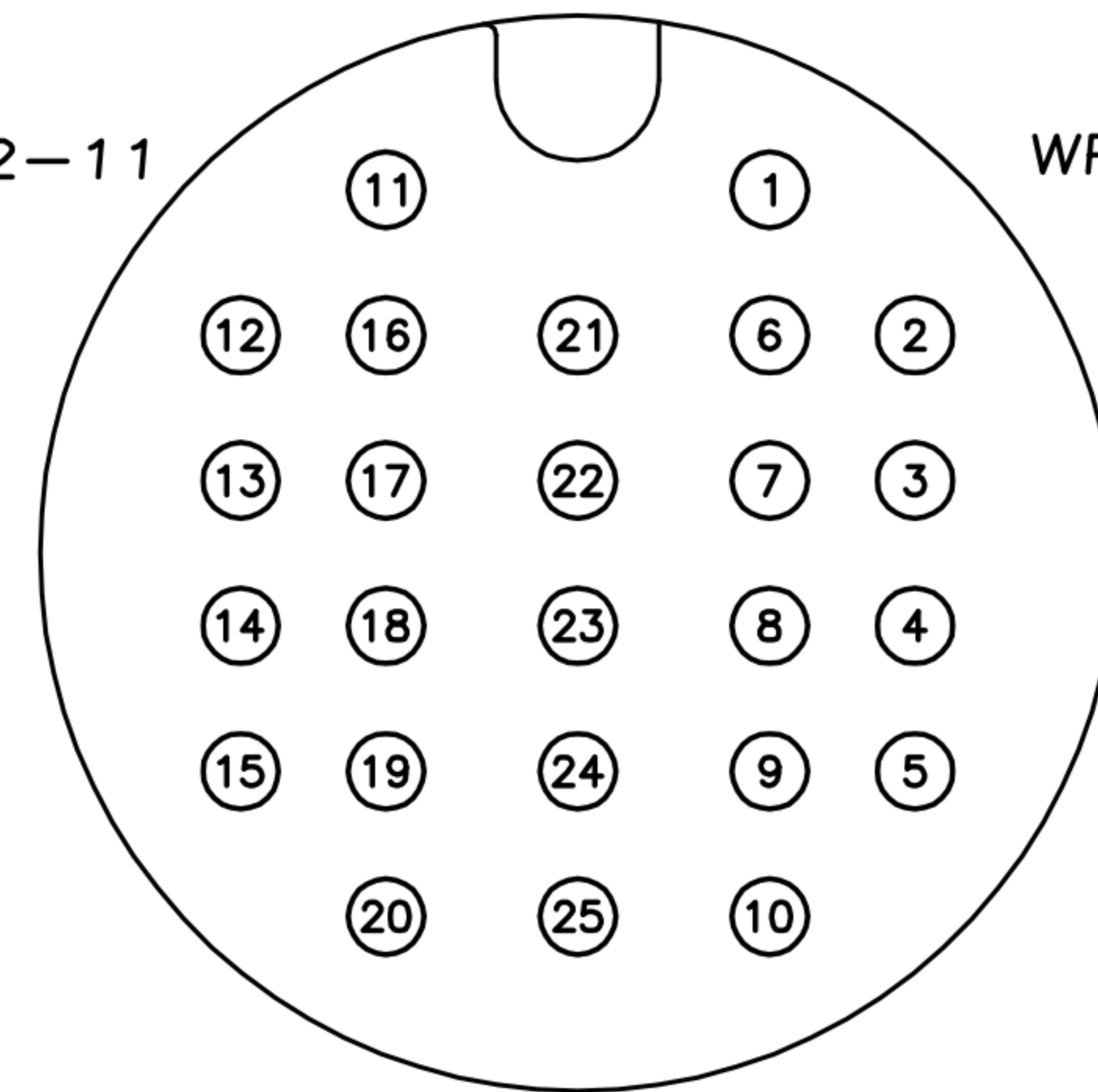

25P
WP-25F2-02-11

PIN CONFIGURATION

DRAWN	Emily Suen	APP'D	KU Chou	UNIT	mm	TOLERANCE		广东科斯达电子科技有限公司 GUANG DONG KE SI DA ELECTRONIC TECHNOLOGY CO., LTD.	TITLE	WP D Size(F Conn. F PIN) Molded with Cabl(Screw Thread)			SHEET
CHK'D	KU Chou			SCALE	1:1	.x ±0.20 .xx ±0.10 .xxx ±0.05 .xxxx ±0.03 ANGULA ±1°			PART NO.	SEE TABLE A	DWG NO.	QC9694	VERSION

CUSTOMER DRAWING

REV.	DESCRIPTION	APPROVED BY	DATE	ECN NO.
△A	RELEASE	KU Chou	22/04/20*	
△B				
△C				
△D				

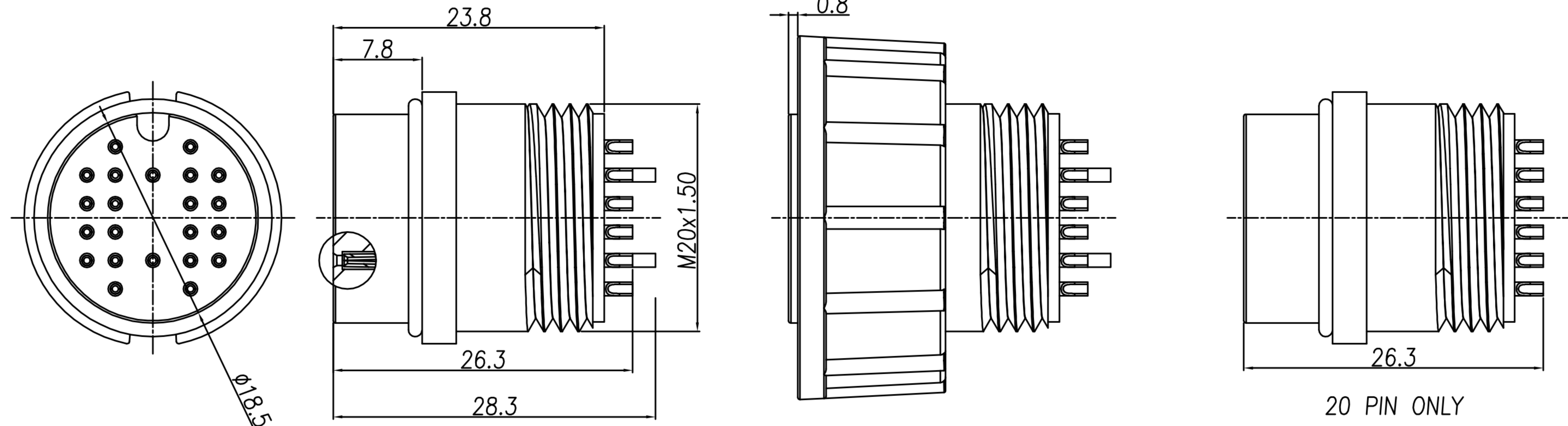

ASS'Y

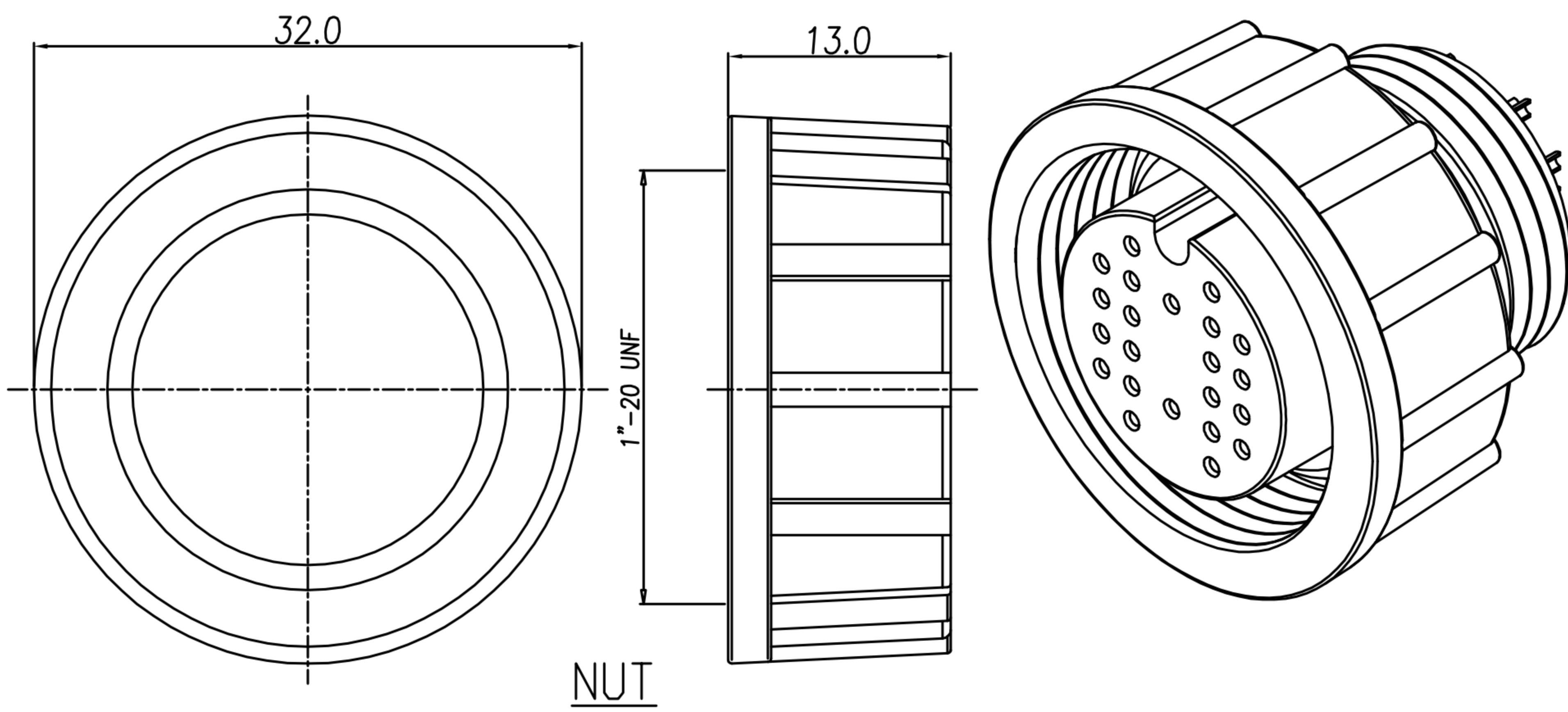

1. MATERIAL :
 - 1-1. HOUSING : PA66
 - 1-2. CONTACT : BRASS
 - 1-3. O-RING : SILICONE
 - 1-4. NUT : PA66
2. FINISH :
 - 2-1. CONTACT : GOLD FLASH PLATED
3. ELECTRICAL SPECIFICATION :
 - 3-1. Rated current : 2A
 - 3-2. Rated Voltage : 300V
4. Environmental :
 - 4-1. Operation Temperature : -20°C~80°C

DRAWN	Emily Suen	APP'D	KU Chou	UNIT	mm	TOLERANCE		广东科斯达电子科技有限公司 GUANG DONG KE SI DA ELECTRONIC TECHNOLOGY CO., LTD.	TITLE	WP D Size(F Conn. F PIN) Molded with Cabl(Screw Thread)			SHEET
CHK'D	KU Chou			SCALE	1:1	.x ±0.20 .xx ±0.10 .xxx ±0.05 .xxxx ±0.03 ANGULA ±1°			PART NO.	SEE TABLE A	DWG NO.	QC9694	VERSION