

CUSTOMER DRAWING

REV.	DESCRIPTION	APPROVED BY	DATE	ECN NO.
B	CHANGE BOM	Ku Chou	10/09/18'	
C	CHANGE CLAMP RING MATERIAL	Ku Chou	30/10/18'	
D	ADD P/N	Ku Chou	25/04/19'	

TABLE A

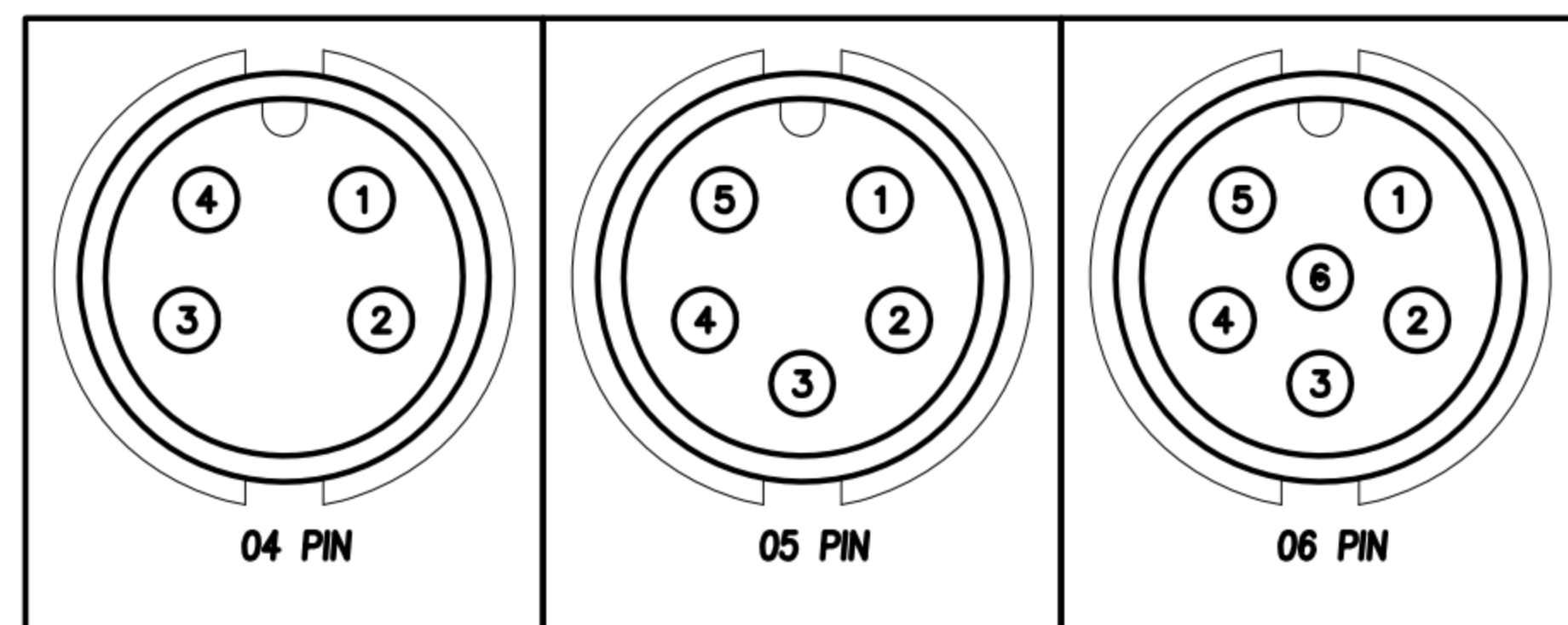

Pin Assignments(Front View)

TABLE A

P/N	CABLE OD ϕ
WP-06F2-89-11	ϕ 8.6mm~ ϕ 9.6mm
WP-06F2-88-11	ϕ 6.5mm~ ϕ 7.6mm
WP-05F2-224-11	ϕ 8.6mm~ ϕ 9.6mm
WP-05F2-149-11	ϕ 6.5mm~ ϕ 7.6mm
WP-04F2-282-11	ϕ 8.6mm~ ϕ 9.6mm
WP-04F2-220-11	ϕ 6.5mm~ ϕ 7.6mm

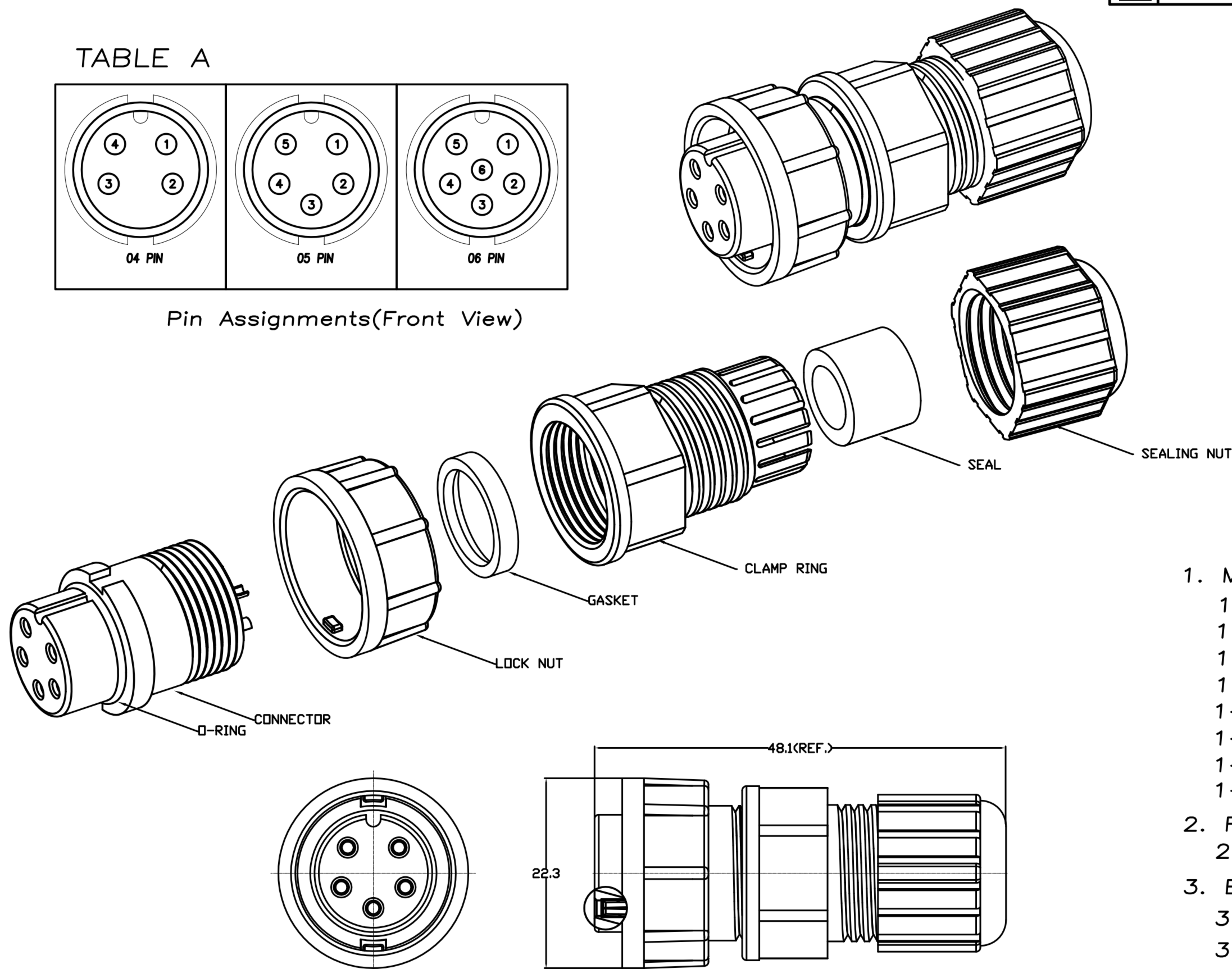

- MATERIAL :
 - HOUSING : PA66
 - CONTACT : BRASS
 - O-RING : SILICONE
 - LOCK NUT : PA66
 - GASKET : SILICONE
 - CLAMP RING : PA66
 - SEAL : SILICONE
 - SEALING NUT : PA66
- FINISH :
 - CONTACT : GOLD FLASH PLATED.
- ELECTRICAL SPECIFICATION :
 - Rated current : 10A
 - Rated Voltage : 250V
 - Water proof : IP67
- Environmental :
 - Operation Temperature : $-40^{\circ}\text{C} \sim 105^{\circ}\text{C}$

DRAWN	Emily Suen	APP'D	Ku Chou	UNIT	mm	TOLERANCE		广东科斯达电子科技有限公司 GUANG DONG KE SI DA ELECTRONIC TECHNOLOGY CO., LTD.	TITLE	WP FEMALE (FEMALE PIN) C SIZE ASSEMBLY TYPE(LOCK)-10A			SHEET	1 VERSION D
CHK'D	Ku Chou			SCALE	1:1				PART NO.	SEE TABLE A	DWG NO.	QC8618		