

CUSTOMER DRAWING

REV.	DESCRIPTION	APPROVED BY	DATE	ECN NO.
B	CHANGE BOM	Ku Chou	10/09/18'	
C	CHANGE CLAMP RING MATERIAL	Ku Chou	30/10/18'	
D	ADD P/N	Ku Chou	12/06/20'	

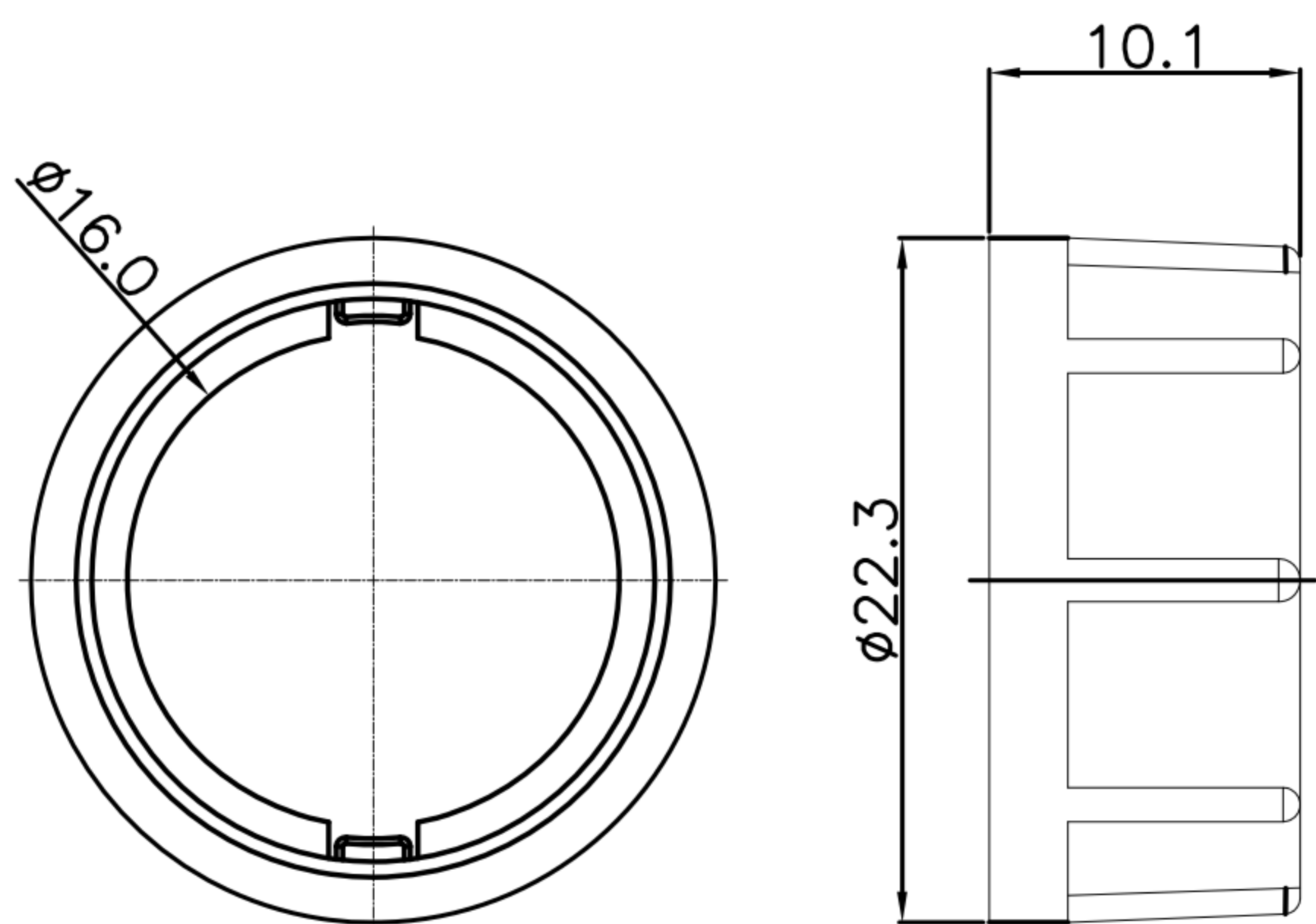

LOCK NUT

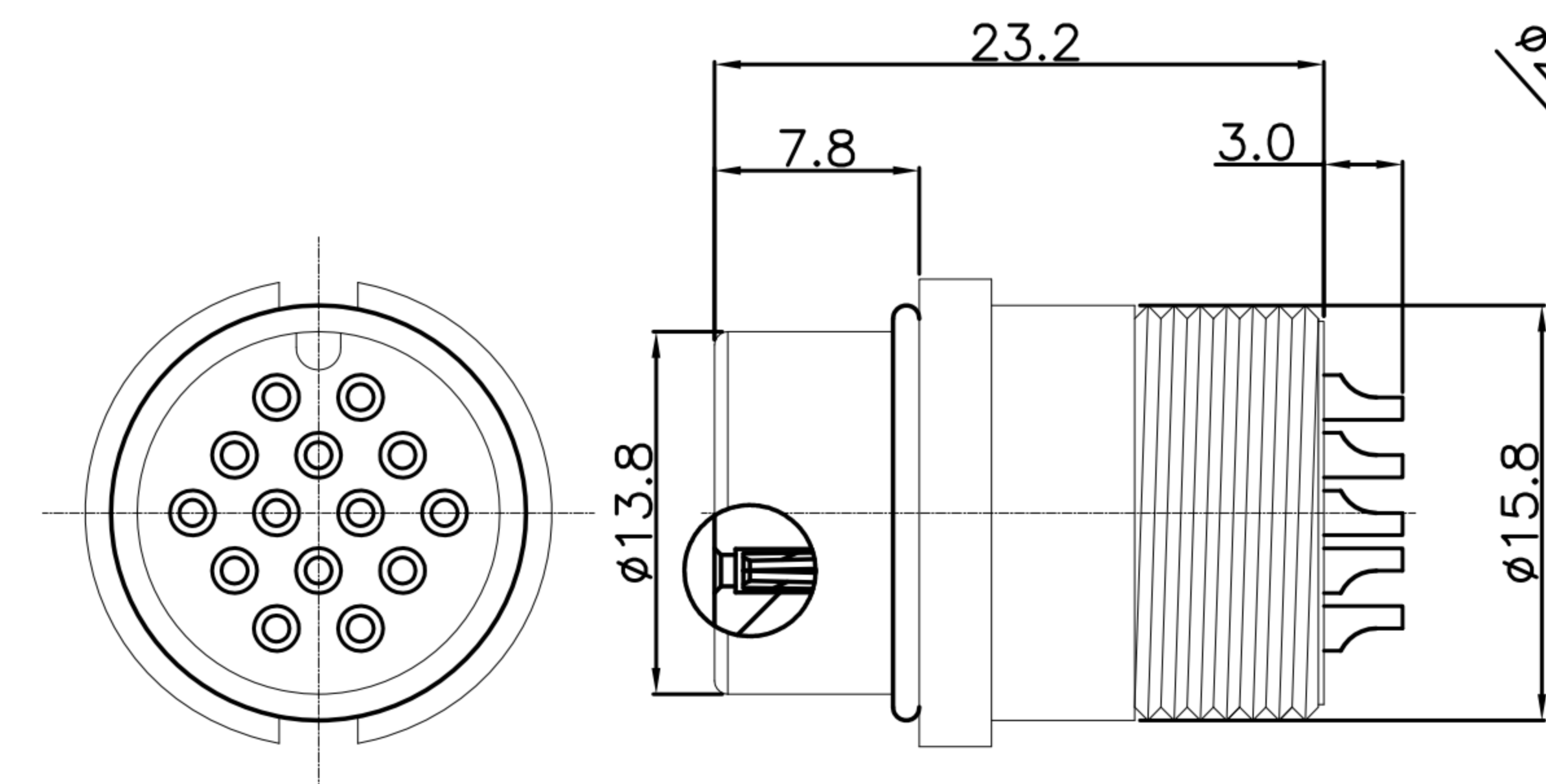
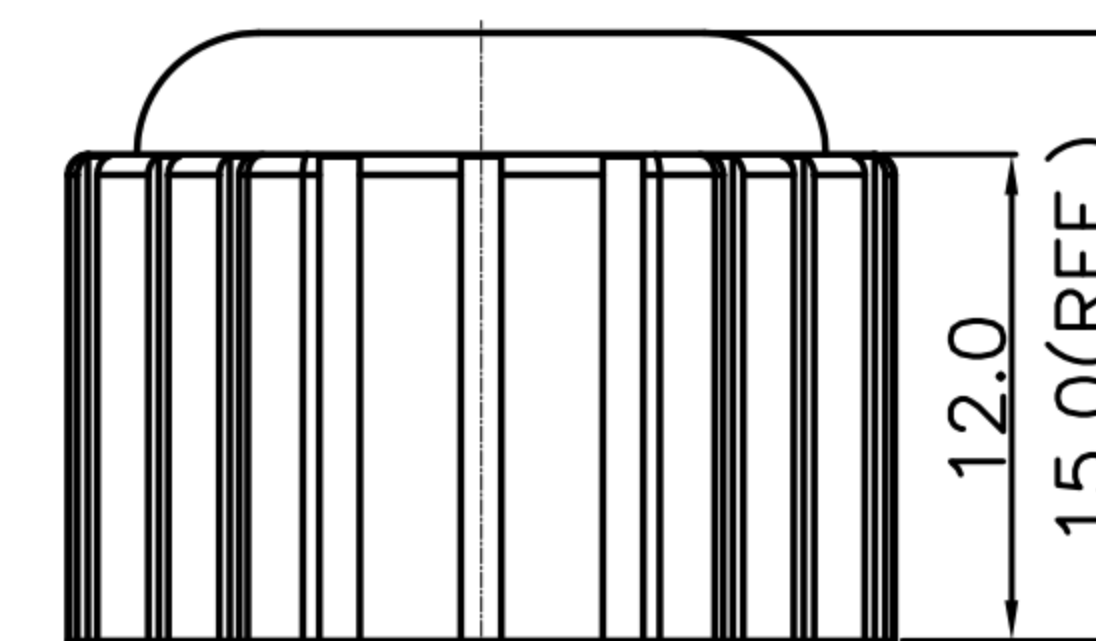

HOUSING & CONTACT & O-RING

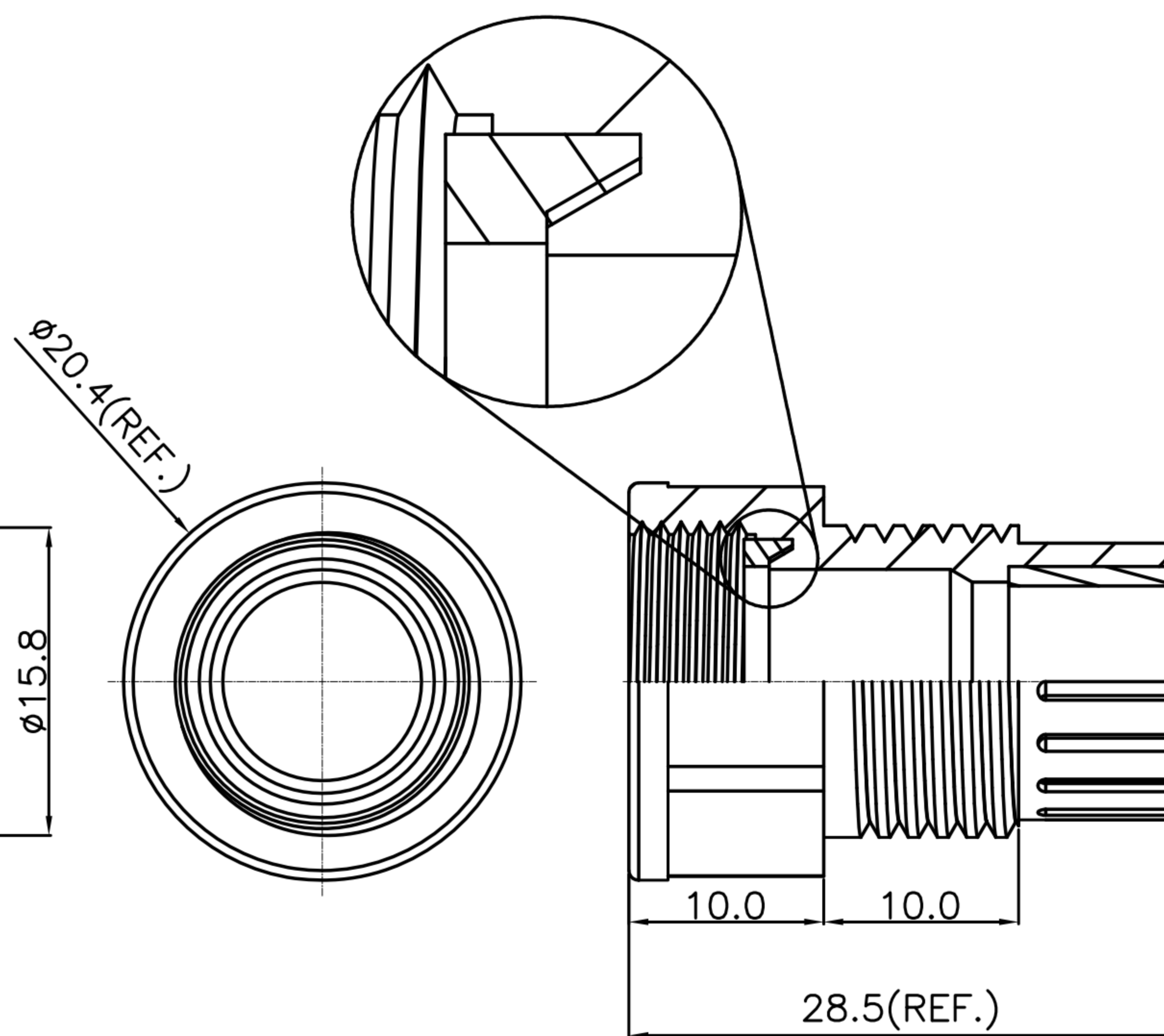

CLAMP & GASKET & SEAL

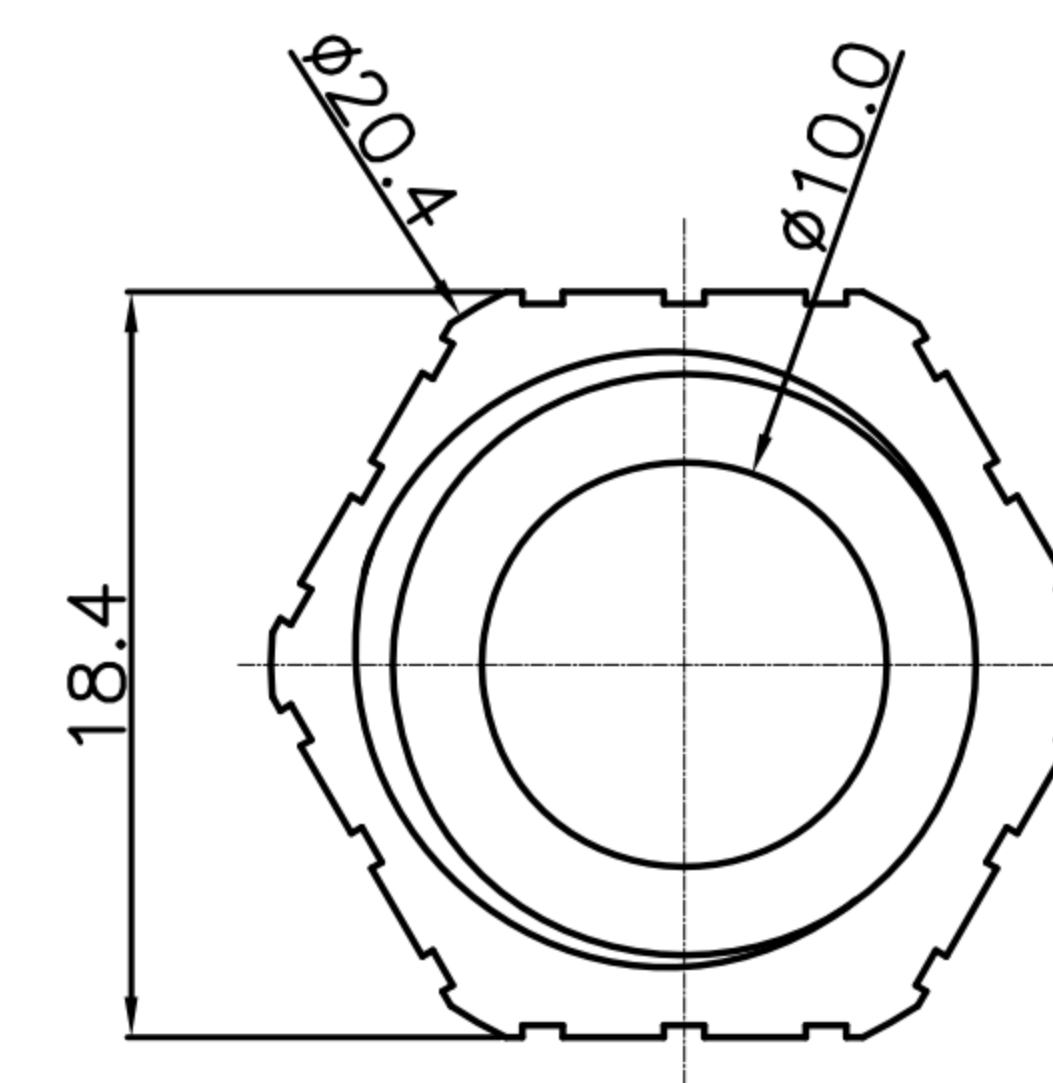

SEALING NUT

DRAWN	Emily Suen	APP'D	Ku Chou	UNIT	mm	TOLERANCE			TITLE	WP FEMALE (FEMALE PIN) C SIZE ASSEMBLY TYPE(LOCK)-5A			SHEET
CHK'D	Ku Chou			SCALE	1:1	.x ±0.20 .xx ±0.10 .xxx ±0.05 .xxxx ±0.03 ANGULAR ±1°			PART NO.	SEE TABLE A	DWG NO.	QC8619	VERSION

广东科斯达电子科技有限公司  
GUANG DONG KE SI DA ELECTRONIC TECHNOLOGY CO., LTD.

# CUSTOMER DRAWING

REV.	DESCRIPTION	APPROVED BY	DATE	ECN NO.
B	CHANGE BOM	Ku Chou	10/09/18'	
C	CHANGE CLAMP RING MATERIAL	Ku Chou	30/10/18'	
D	ADD P/N	Ku Chou	12/06/20'	

TABLE A

07 PIN	08 PIN	09 PIN
10 PIN	12 PIN	14 PIN

Pin Assignments  
Front View

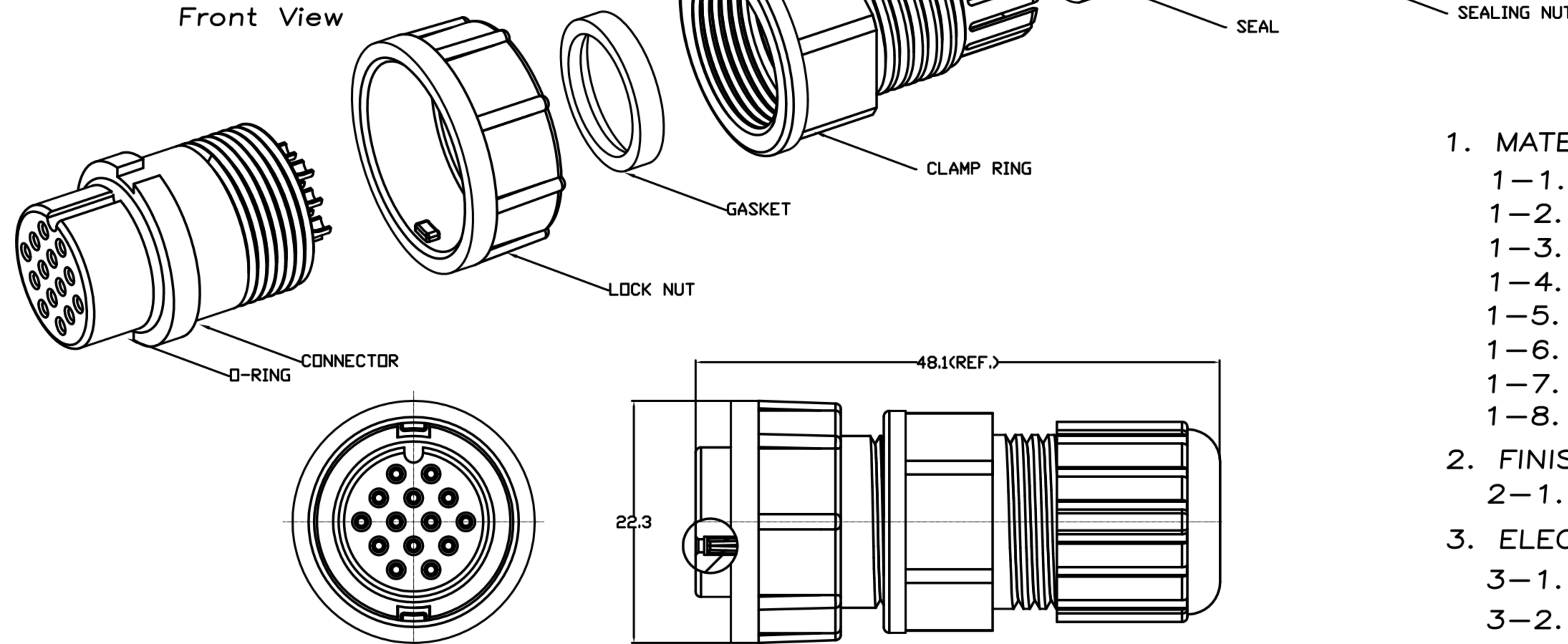

TABLE A

P/N	CABLE OD $\phi$
WP-07F2-17-11	$\phi 6.5\text{mm} \sim \phi 7.6\text{mm}$
WP-08F2-122-11	$\phi 6.5\text{mm} \sim \phi 7.6\text{mm}$
WP-09F2-30-11	$\phi 6.5\text{mm} \sim \phi 7.6\text{mm}$
WP-09F2-35-11	$\phi 8.6\text{mm} \sim \phi 9.6\text{mm}$
WP-10F2-18-11	$\phi 6.5\text{mm} \sim \phi 7.6\text{mm}$
WP-12F2-37-11	$\phi 6.5\text{mm} \sim \phi 7.6\text{mm}$
WP-14F2-01-11	$\phi 6.5\text{mm} \sim \phi 7.6\text{mm}$
WP-14F2-04-11	$\phi 8.6\text{mm} \sim \phi 9.6\text{mm}$

- MATERIAL :
  - 1-1. HOUSING : PA66
  - 1-2. CONTACT : BRASS
  - 1-3. O-RING : SILICONE
  - 1-4. LOCK NUT : PA66
  - 1-5. GASKET : SILICONE
  - 1-6. CLAMP RING : PA66  $\triangle$
  - 1-7. SEAL : SILICONE
  - 1-8. SEALING NUT : PA66
- FINISH :
  - 2-1. CONTACT : GOLD FLASH PLATED.
- ELECTRICAL SPECIFICATION :
  - 3-1. Rated current : 5A
  - 3-2. Rated Voltage : 250V
  - 3-3. Water proof : IP67
- Environmental :
  - 4-1. Operation Temperature :  $-40^{\circ}\text{C} \sim 105^{\circ}\text{C}$

DRAWN	Emily Suen	APP'D	Ku Chou	UNIT	mm	TOLERANCE		广东科斯达电子科技有限公司 GUANG DONG KE SI DA ELECTRONIC TECHNOLOGY CO., LTD.	TITLE	WP FEMALE (FEMALE PIN) C SIZE ASSEMBLY TYPE(LOCK)-5A			SHEET	1/2
CHK'D	Ku Chou			SCALE	1:1	.x $\pm 0.20$ .xx $\pm 0.10$ .xxx $\pm 0.05$ .xxxx $\pm 0.03$ ANGULAR $\pm 1^{\circ}$			PART NO.	SEE TABLE A	DWG NO.	QC8619	VERSION	D