

# CUSTOMER DRAWING

REV.	DESCRIPTION	APPROVED BY	DATE	ECN NO.
B	CHANGE BOM	Ku Chou	10/09/18'	
C	ADD PART No.	Ku Chou	23/10/18'	
D	CHANGE CLAMP RING MATERIAL	Ku Chou	30/10/18'	

TABLE A

10 PIN	18 PIN	20 PIN
	WP-18F2-15-11	WP-20F2-02-11

Pin Assignments(Front View)

TABLE A

P/N	CABLE ODφ	
	φ8.6mm~φ9.6mm	φ6.5mm~φ7.6mm
WP-18F2-15-11	V	V
WP-20F2-02-11	V	

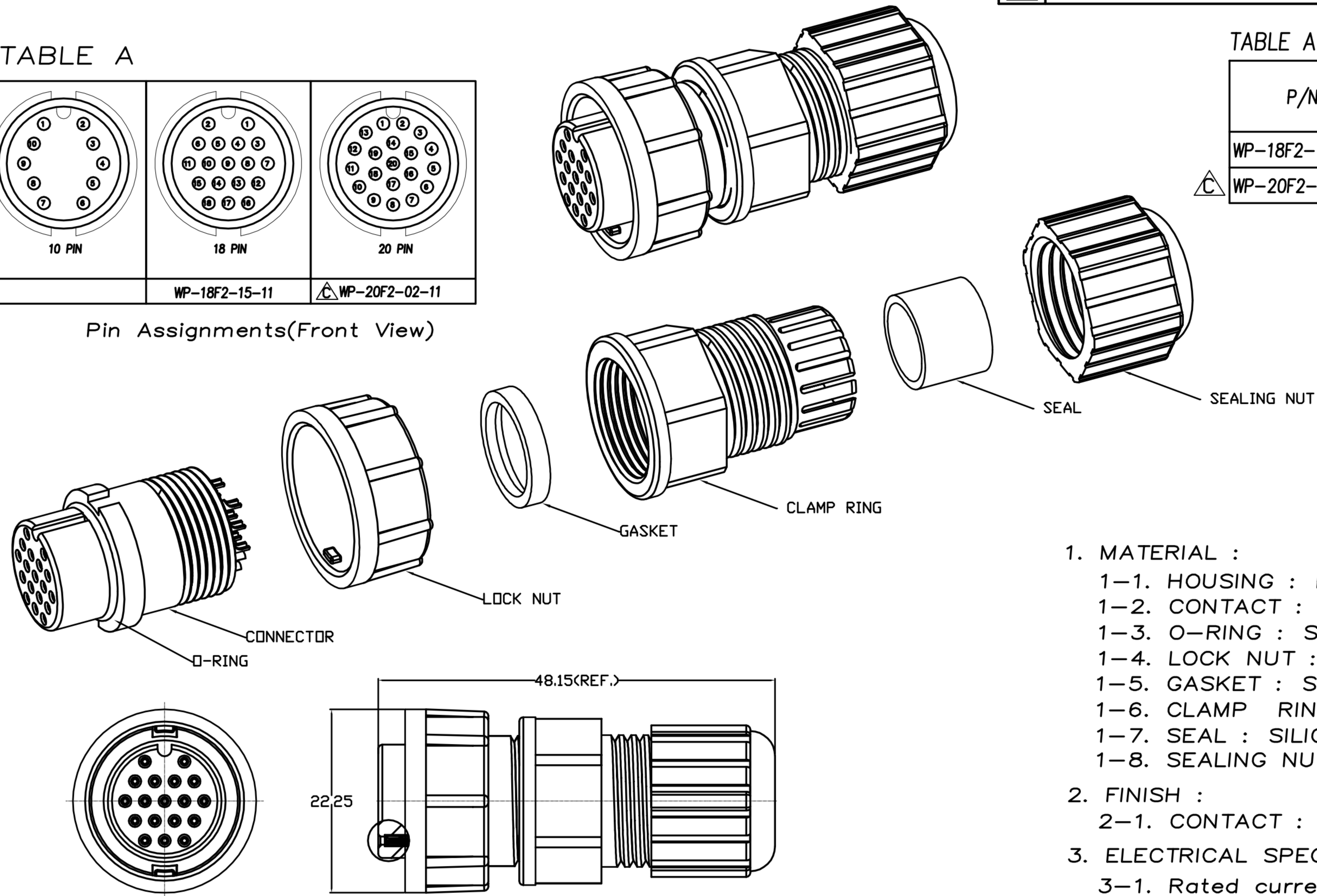

1. MATERIAL :

- 1-1. HOUSING : PA66
- 1-2. CONTACT : BRASS
- 1-3. O-RING : SILICONE
- 1-4. LOCK NUT : PA66
- 1-5. GASKET : SILICONE
- 1-6. CLAMP RING : PA66
- 1-7. SEAL : SILICONE
- 1-8. SEALING NUT : PA66

2. FINISH :

- 2-1. CONTACT : GOLD FLASH PLATED.

3. ELECTRICAL SPECIFICATION :

- 3-1. Rated current : 2A
- 3-2. Rated Voltage : 250V
- 3-3. Water proof : IP67

4. Environmental :

- 4-1. Operation Temperature : -40℃~105℃

DRAWN	Emily Suen	APP'D	Ku Chou	UNIT	mm	TOLERANCE		 广东科斯达电子科技有限公司 GUANG DONG KE SI DA ELECTRONIC TECHNOLOGY CO., LTD.	TITLE	WP FEMALE (FEMALE PIN) C SIZE ASSEMBLY TYPE(LOCK)-2A			SHEET	
CHK'D	Ku Chou			SCALE	1:1	.x ±0.20 .xx ±0.10 .xxx ±0.05 .xxxx ±0.03 ANGULAR ±1°			PART NO.	SEE TABLE A	DWG NO.	QC8590	VERSION	