

CUSTOMER DRAWING

| REV. | DESCRIPTION | APPROVED BY | DATE | ECN NO. |
|------|-------------|-------------|-----------|---------|
| A | RELEASE | Ku Chou | 31/07/18' | |
| B | | | | |
| C | | | | |

TABLE A

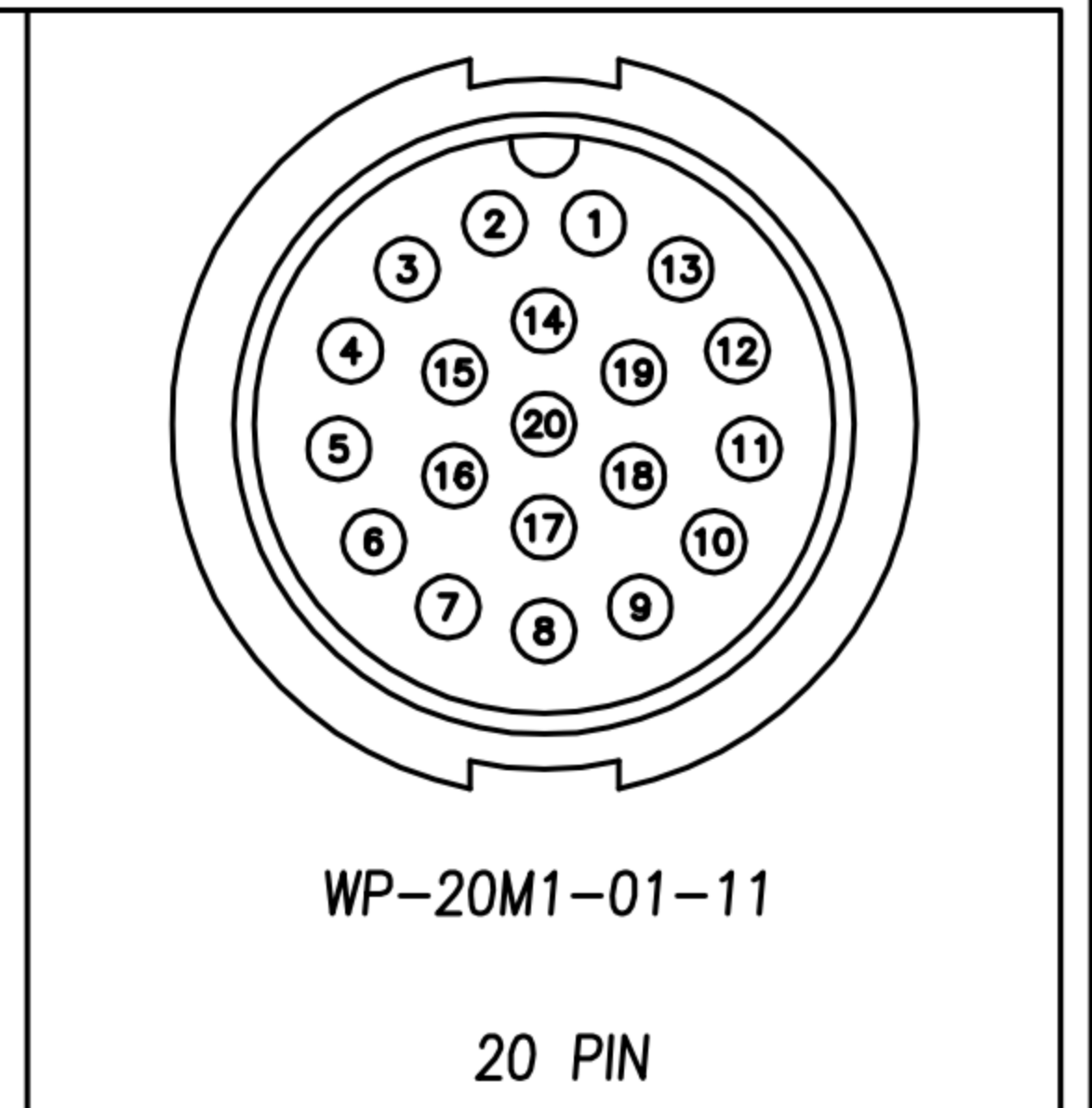
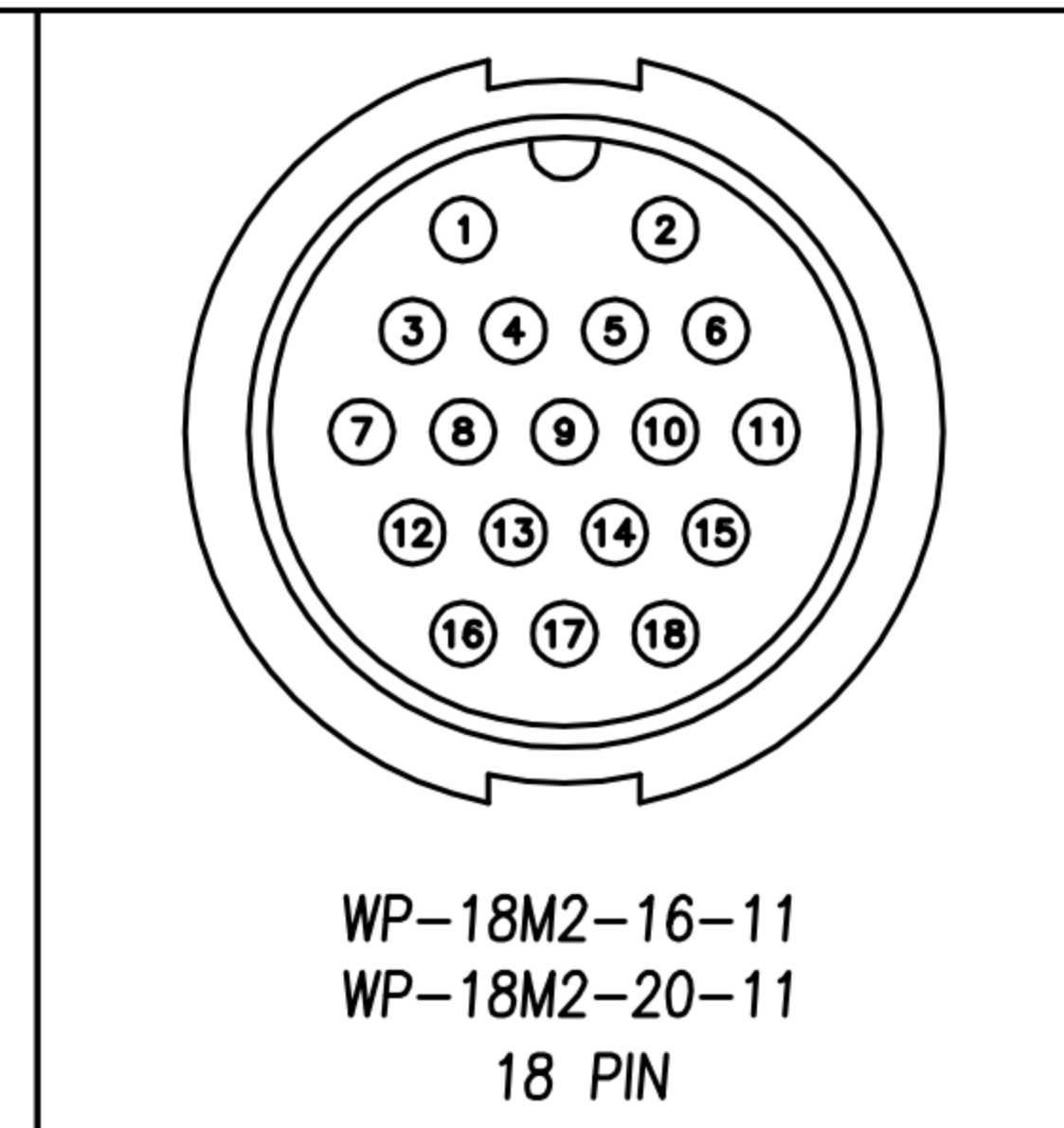
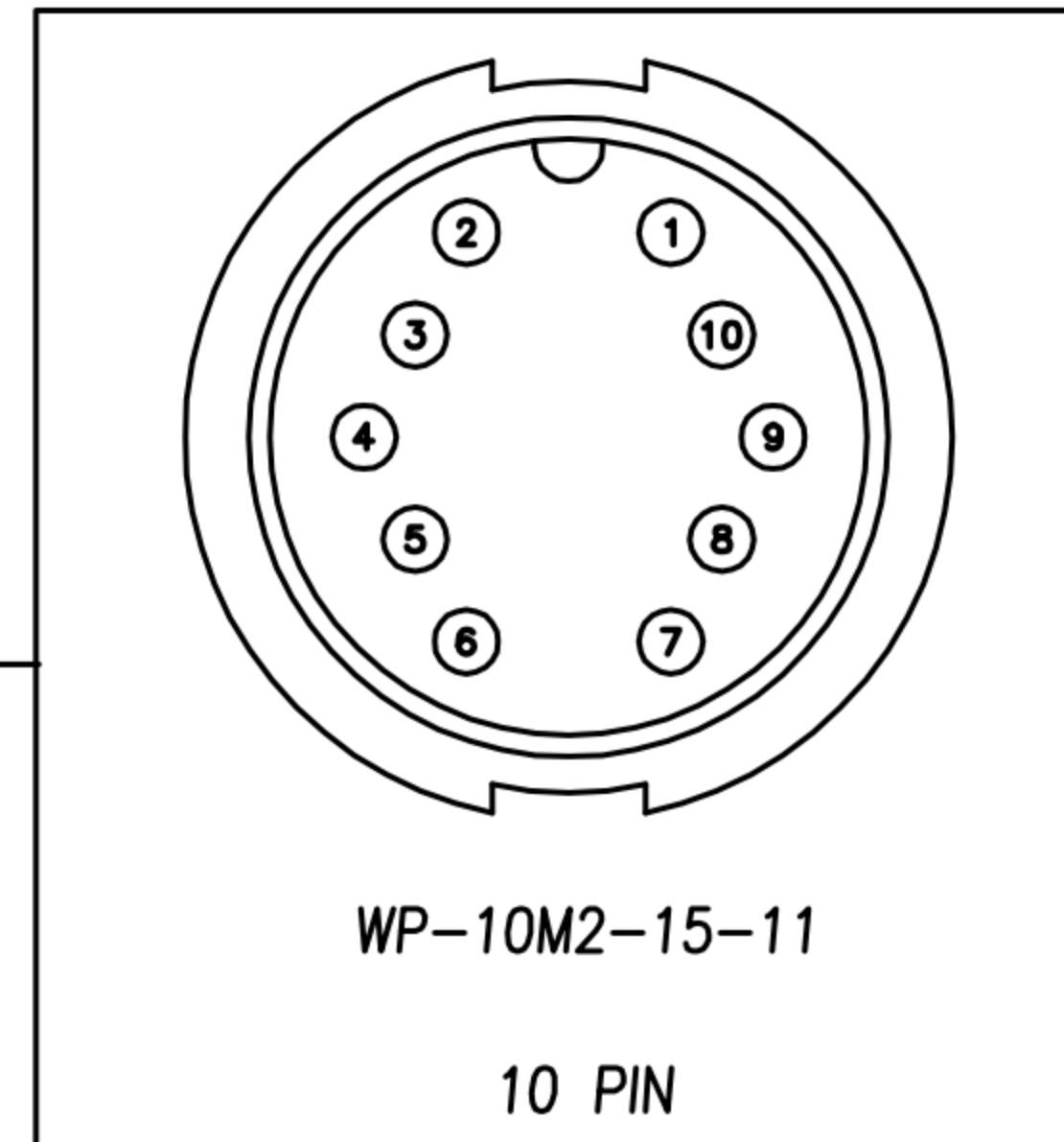
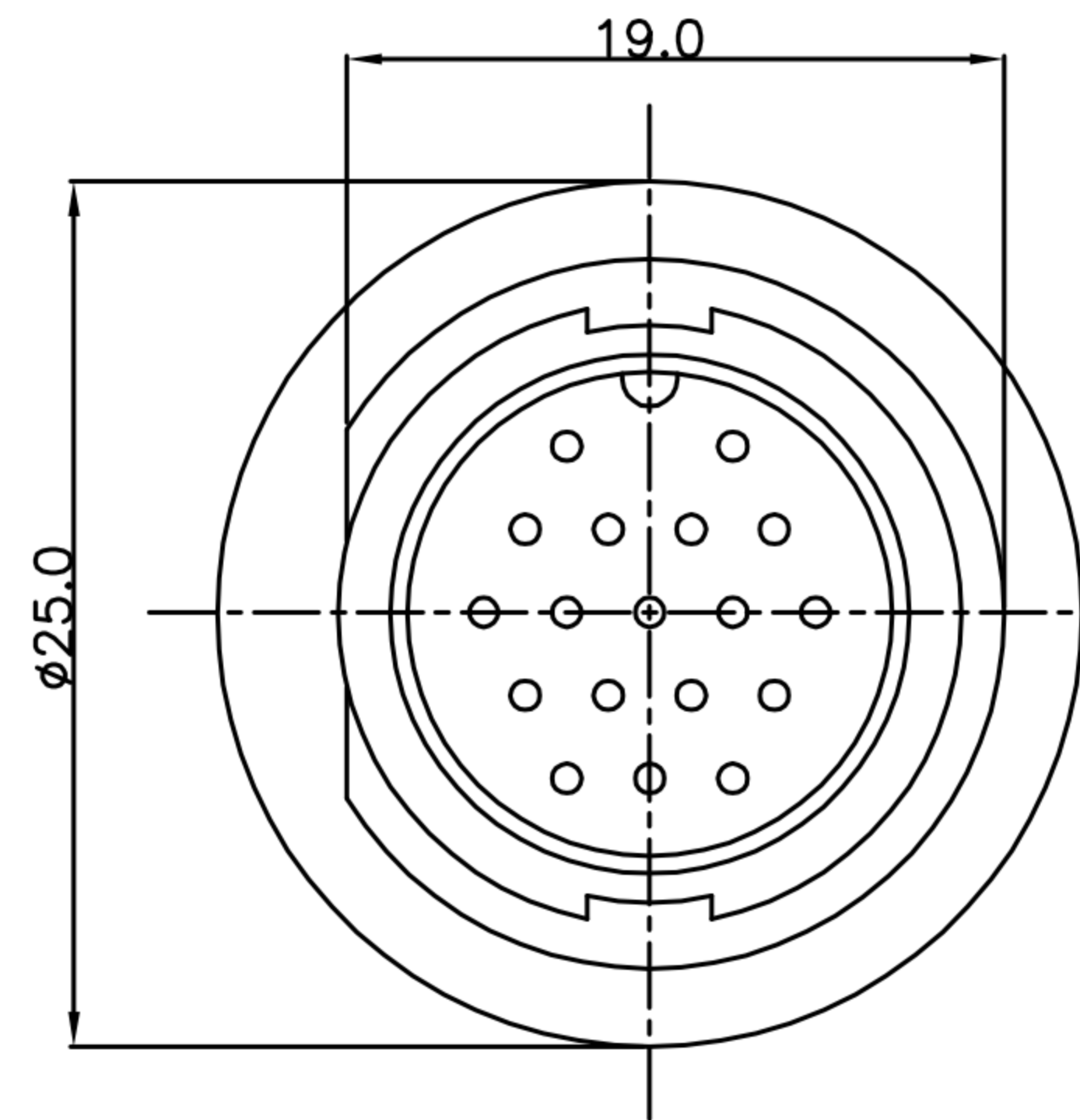
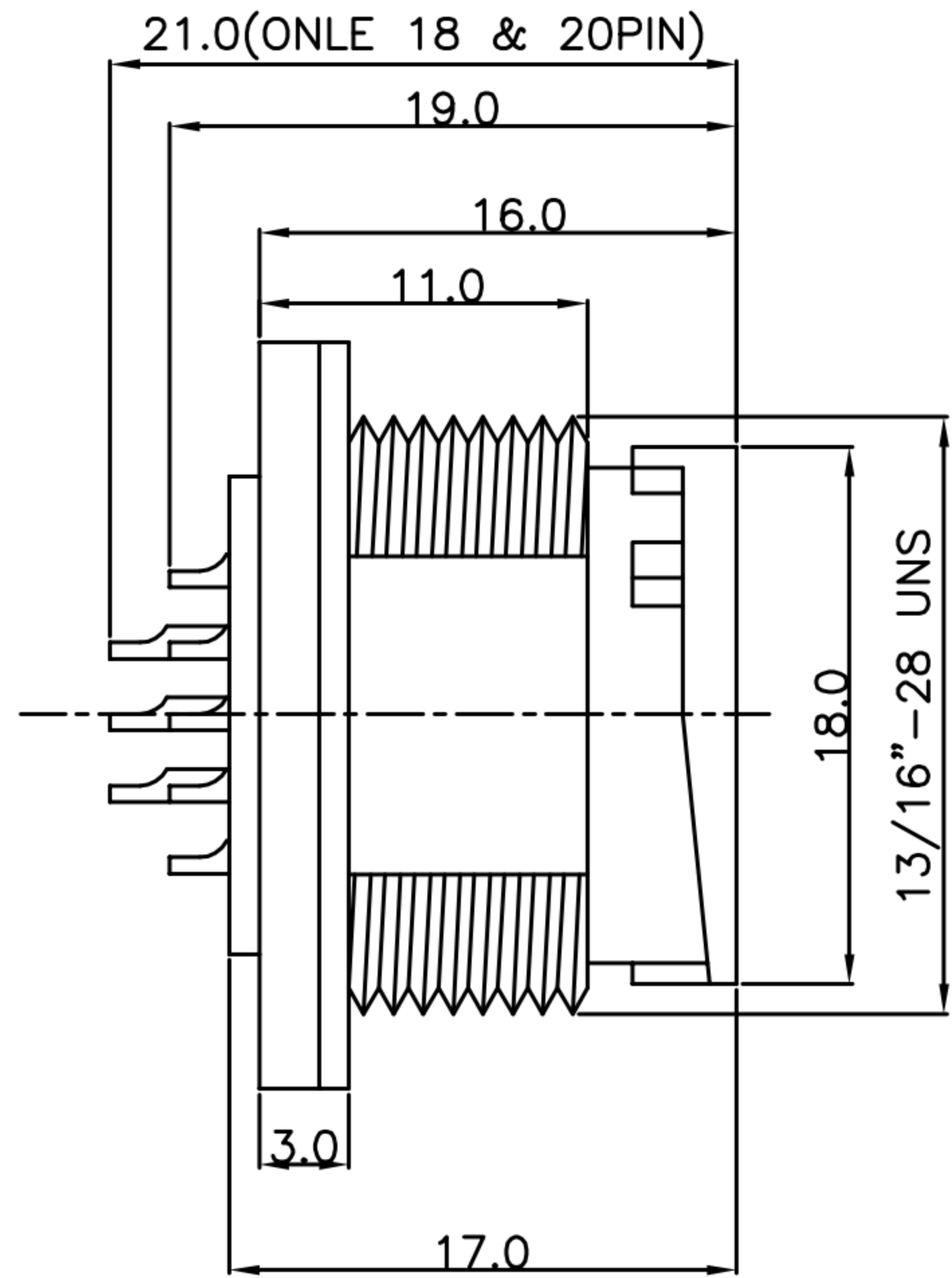

| | |
|---------------|----------------------|
| WP-18M2-20-11 | 6u" GOLD PLATED/金6u" |
| WP-20M1-01-11 | GOLD FLASH PLATED/表金 |
| WP-18M2-16-11 | GOLD FLASH PLATED/表金 |
| WP-10M2-15-11 | GOLD FLASH PLATED/表金 |
| P/N | FINISH |

- MATERIAL :
 - 1-1. HOUSING : PA66
 - 1-2. CONTACT : BRASS
 - 1-3. GASKET : SILICONE
 - 1-4. HEX NUT : PA66
- FINISH :
 - 2-1. CONTACT : SEE TABLE A
- ELECTRICAL SPECIFICATION :
 - 3-1. Rated current : 2A
 - 3-2. Rated Voltage : 250V
 - 3-3. Water proof : IP67
- Environmental :
 - 4-1. Operation Temperature : -40°C~105°C

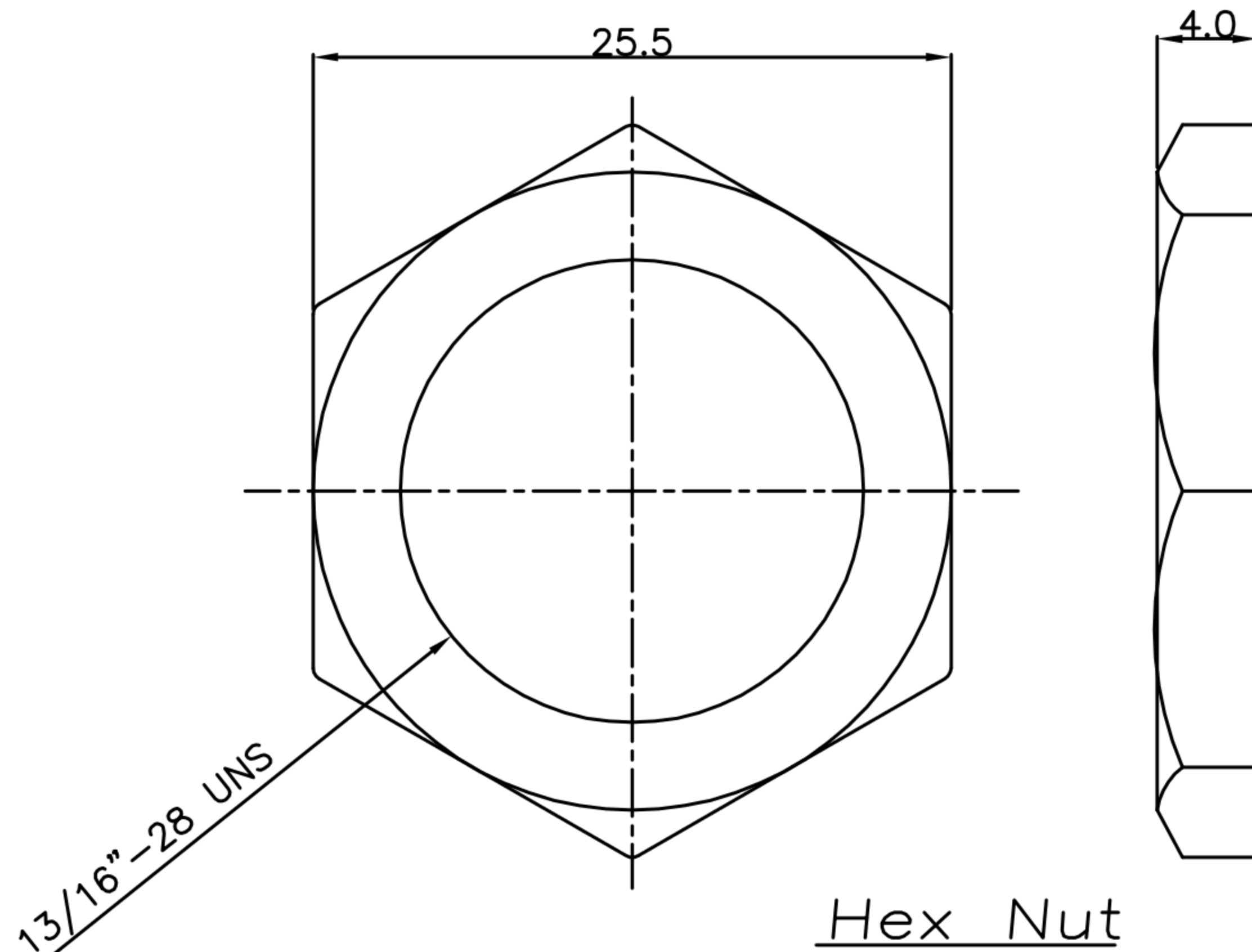
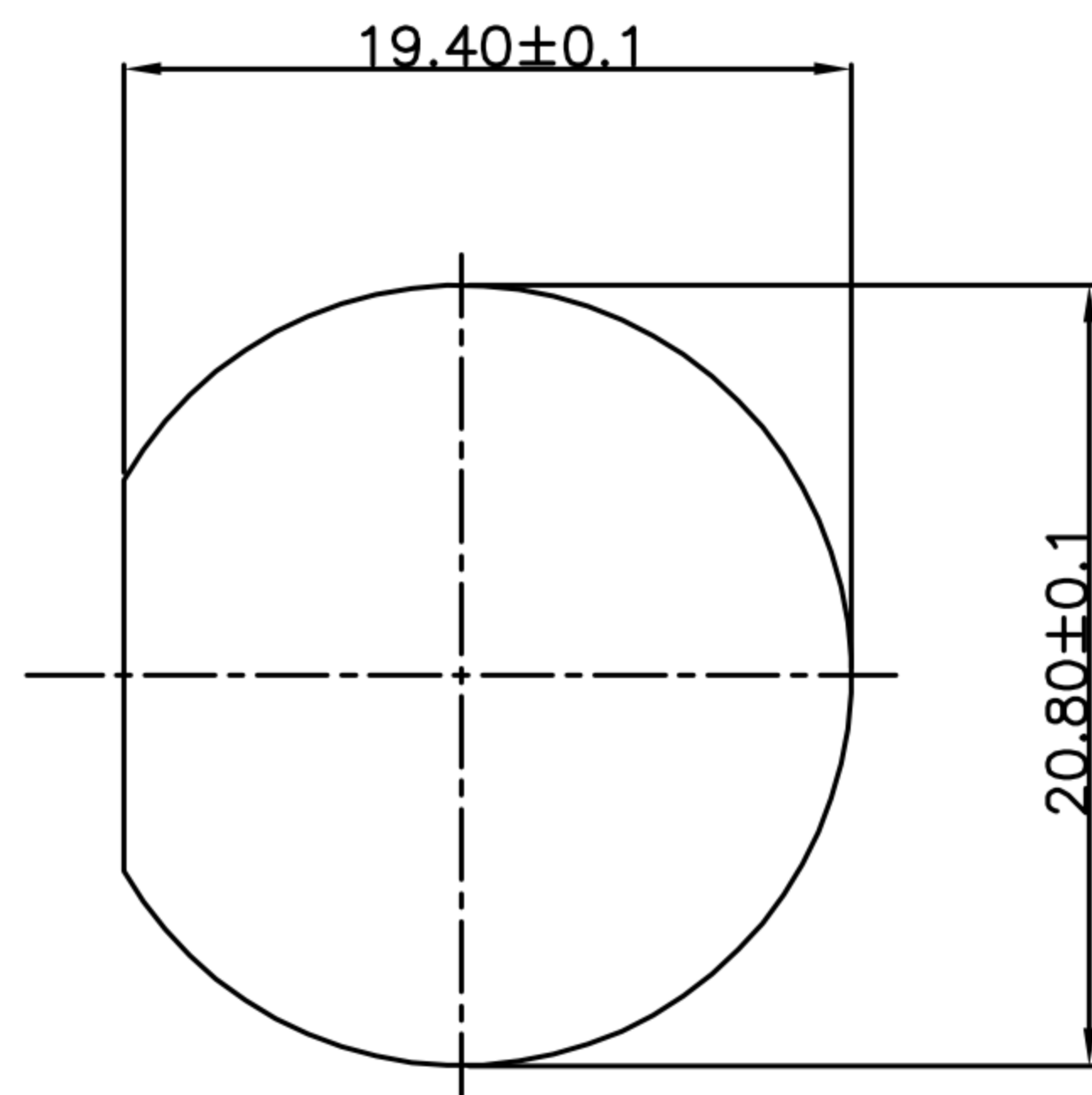

| | | | | | | | | | | | | | |
|-------|------------|-------|---------|-------|-----|-----------|--|----------------------------------------------------------------------|----------|---------------------------------------------------|---------|--------|---------|
| DRAWN | Emily Suen | APP'D | Ku Chou | UNIT | mm | TOLERANCE | | 广东科斯达电子科技有限公司 GUANG DONG KE SI DA ELECTRONIC TECHNOLOGY CO., LTD. | TITLE | WP C Size(M) Front Lock Solder Type(Lock Bayonet) | | | SHEET |
| CHK'D | Ku Chou | | | SCALE | 1:1 | | | | PART NO. | SEE TABLE A | DWG NO. | QC8563 | VERSION |