

CUSTOMER DRAWING

REV.	DESCRIPTION	APPROVED BY	DATE	ECN NO.
A	RELEASE	Ku Chou	10/03/20*	
B				
C				

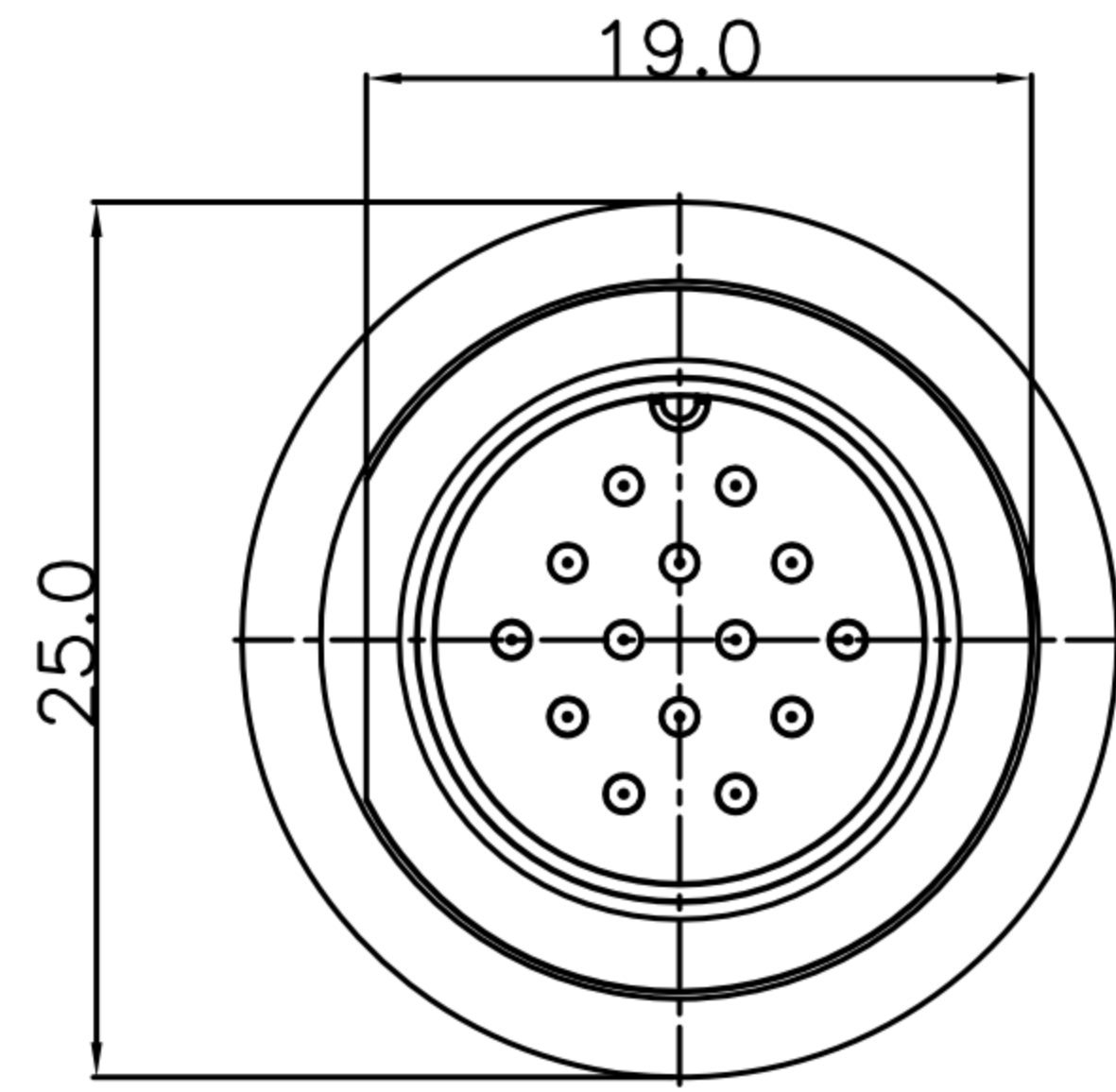
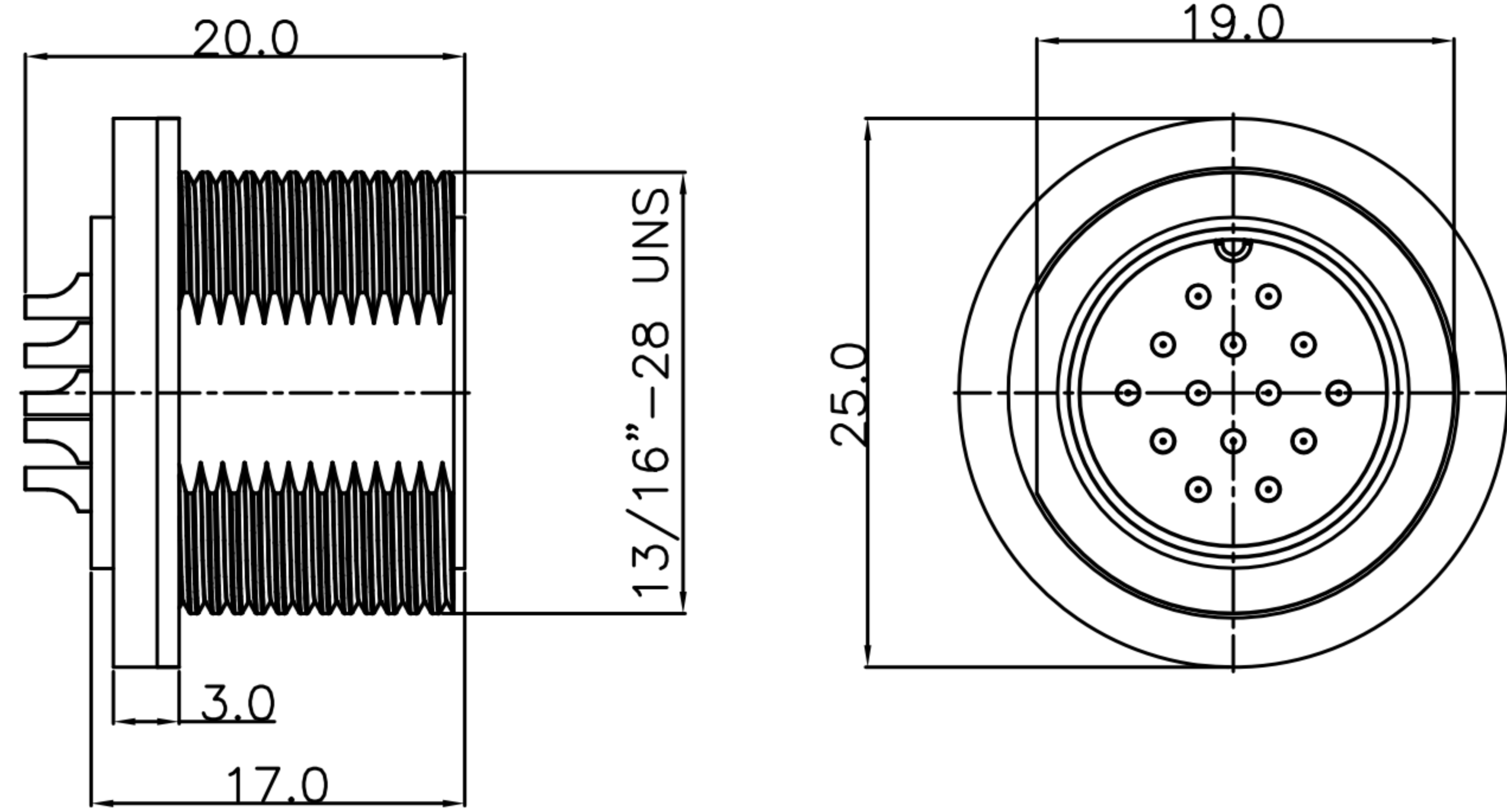
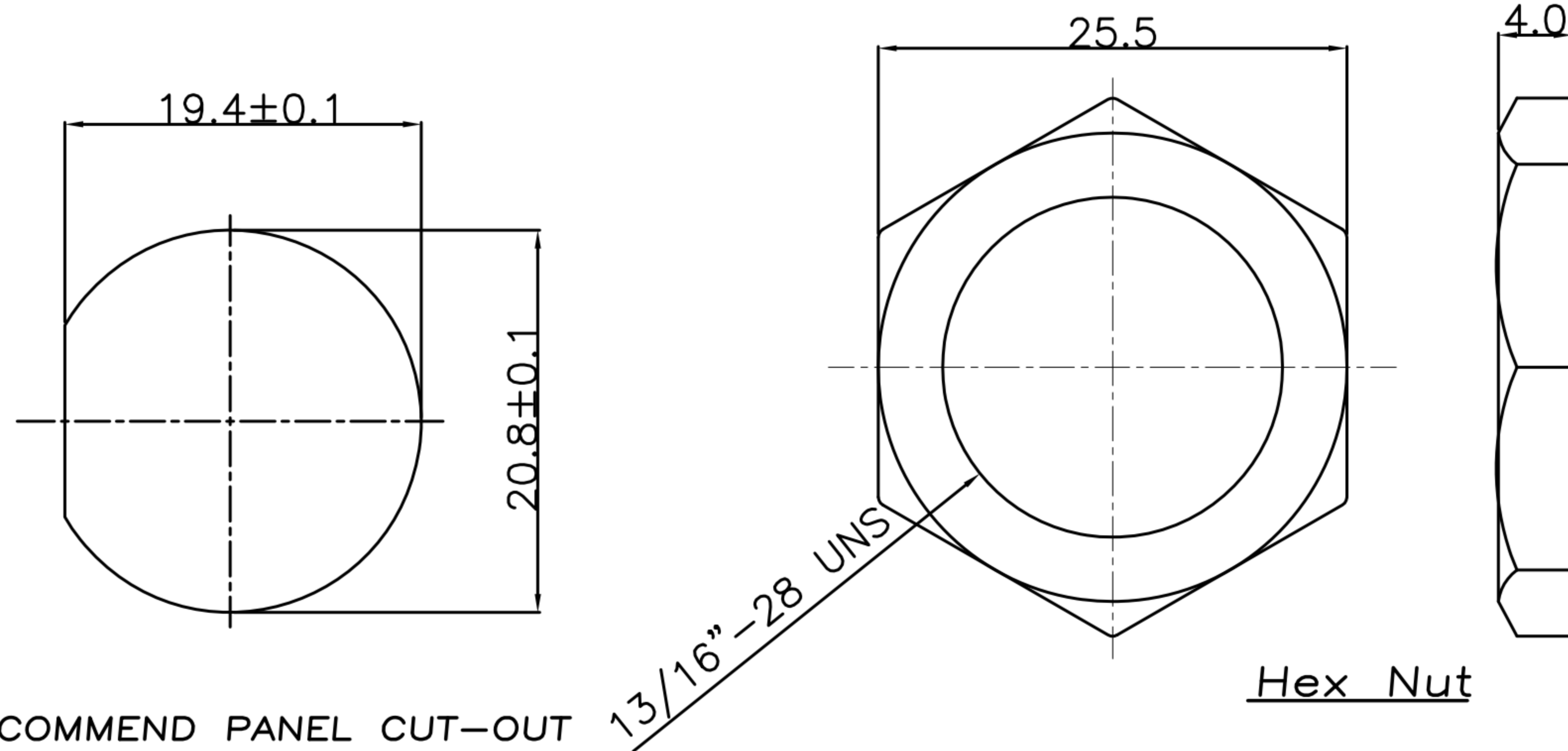

TABLE A

WP-07M2-23-11	WP-08M2-119-11	WP-09M2-21-11
WP-10M2-19-11	WP-12M2-31-11	WP-14M2-04-11

Pin Assignments

- MATERIAL :
 - HOUSING : PA66
 - CONTACT : BRASS
 - GASKET : SILICONE
 - HEX NUT : PA66
- FINISH :
 - CONTACT : GOLD FLASH PLATED.
- ELECTRICAL SPECIFICATION :
 - Rated current : 5A
 - Rated Voltage : 250V
 - Water proof : IP67
- Environmental :
 - Operation Temperature : -40℃~105℃



RECOMMEND PANEL CUT-OUT

Hex Nut

DRAWN	Emily Suen	APP'D	Ku Chou	UNIT	mm	TOLERANCE		广东科斯达电子科技有限公司 GUANG DONG KE SI DA ELECTRONIC TECHNOLOGY CO., LTD.	TITLE	WP C Size(M) Front Lock Solder Type(Screw Thread)			SHEET	1
CHK'D	Ku Chou			SCALE	1:1				PART NO.	SEE TABLE A	DWG NO.	QC10206	VERSION	