

CUSTOMER DRAWING

REV.	DESCRIPTION	APPROVED BY	DATE	ECN NO.
△A	RELEASE	Emily Suen	22/08/11*	
△B				
△C				
△D				

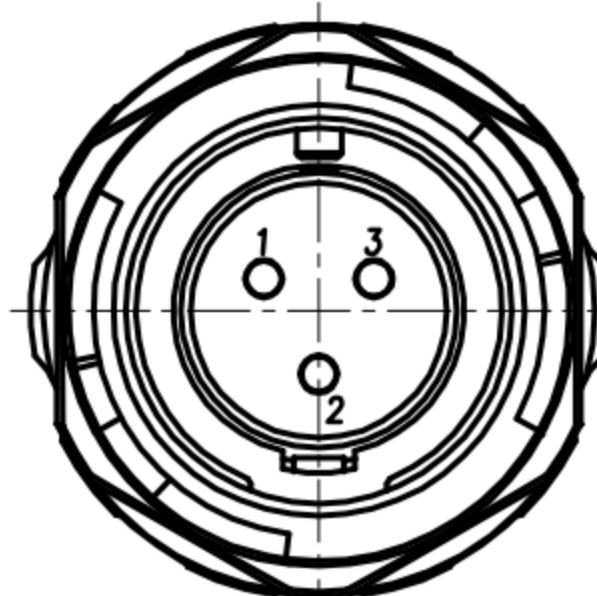

3P

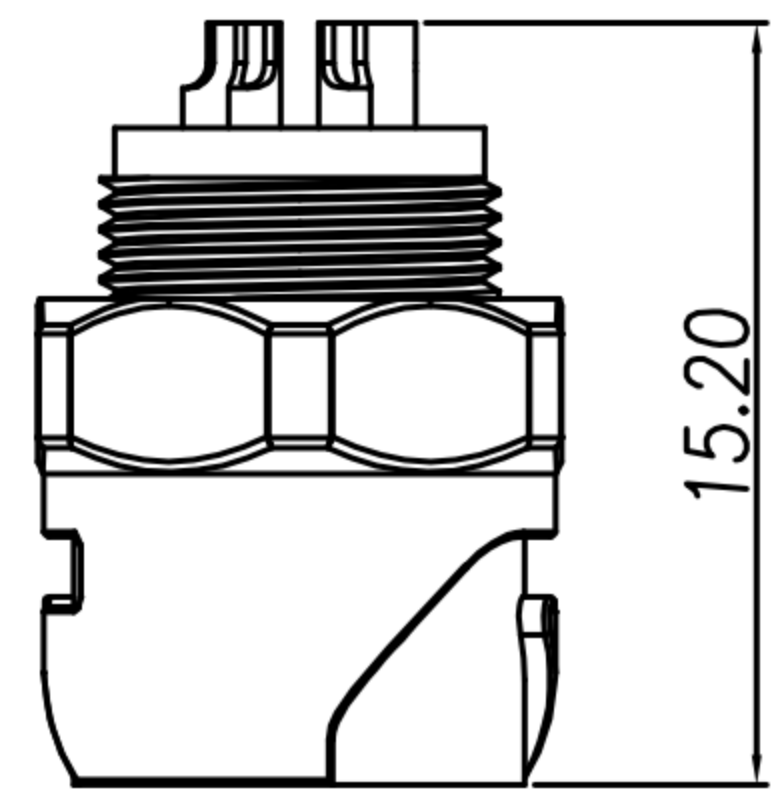
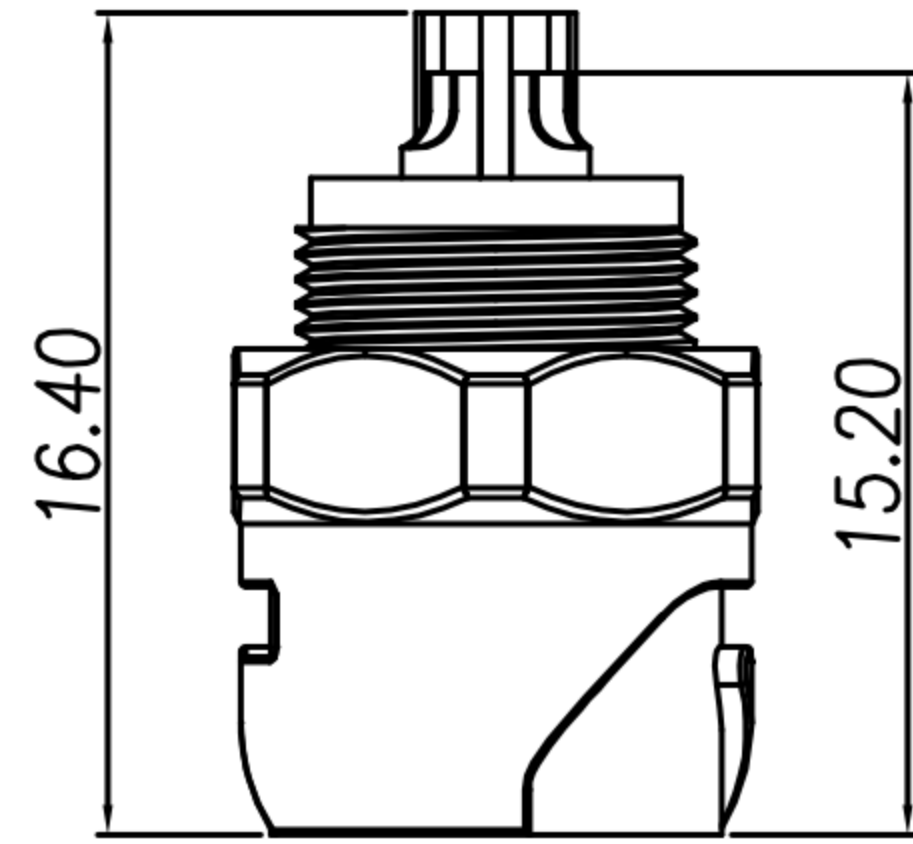
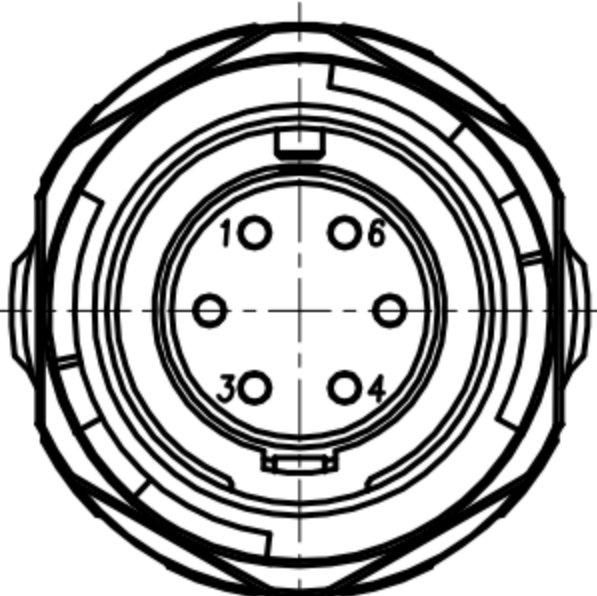

6P

HOUSING+CONTACT+JACK SHELL

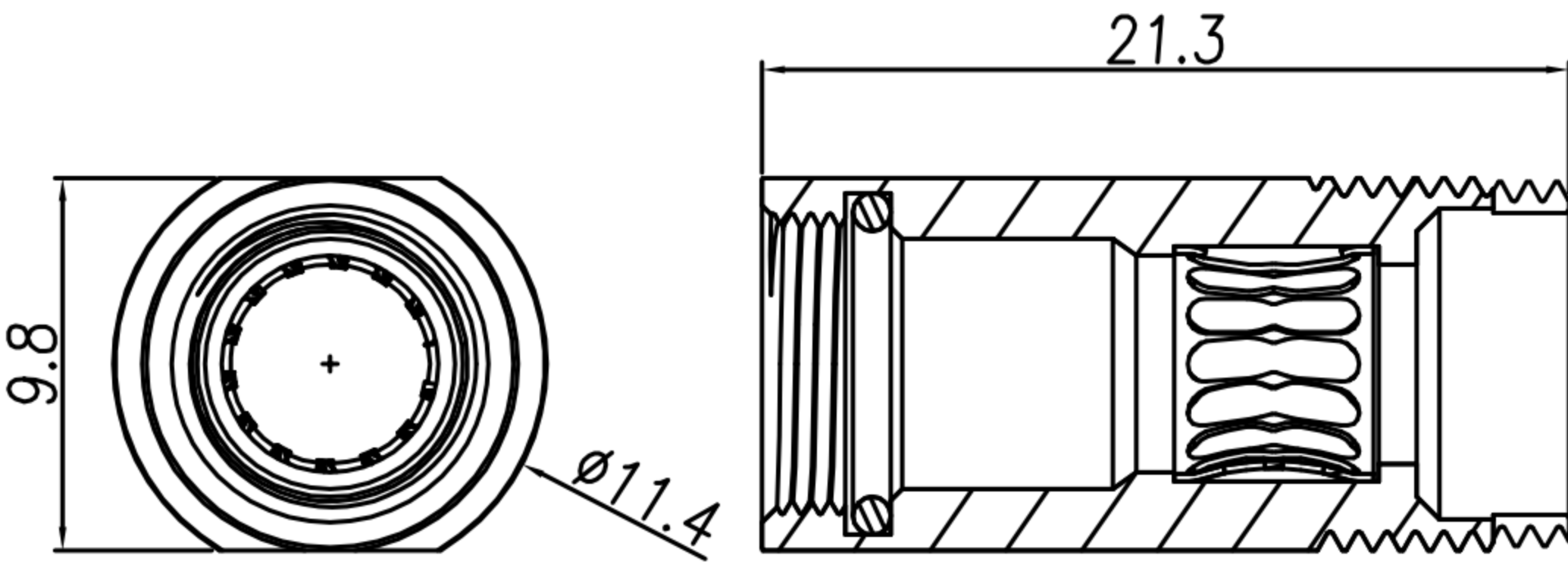

BACK SHELL+SHIELDING+O-RING2

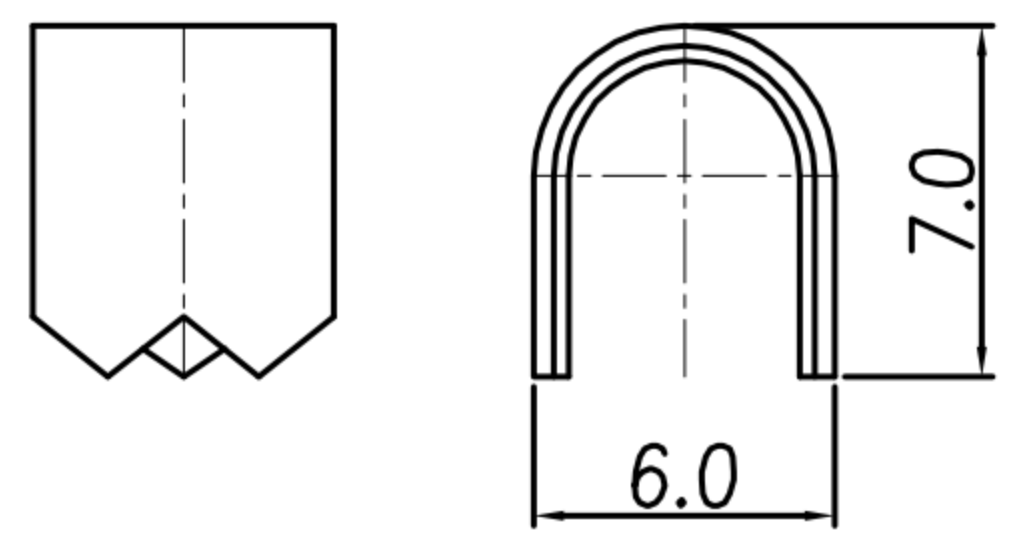

CRAMP

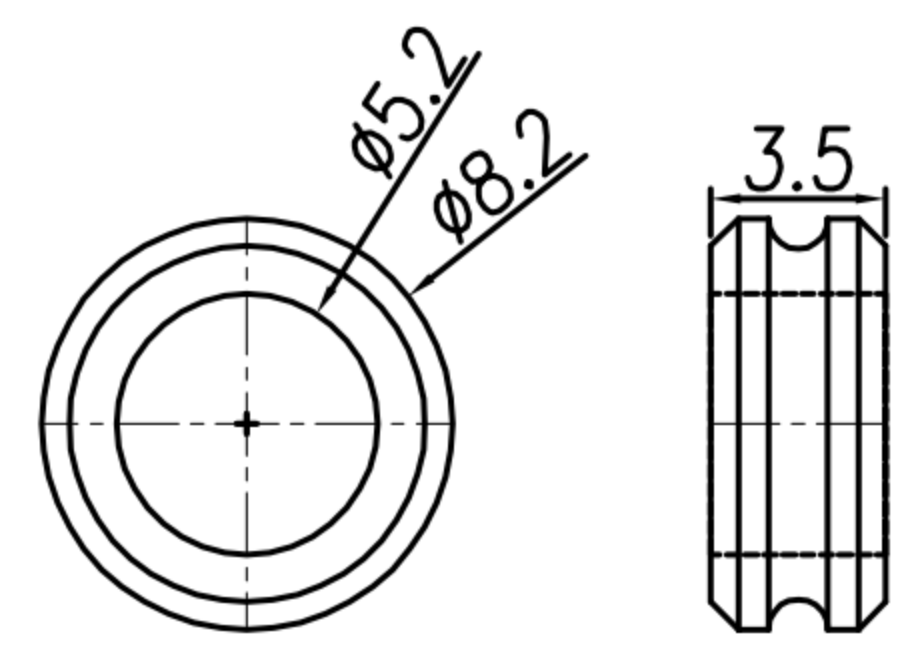

O-RING3

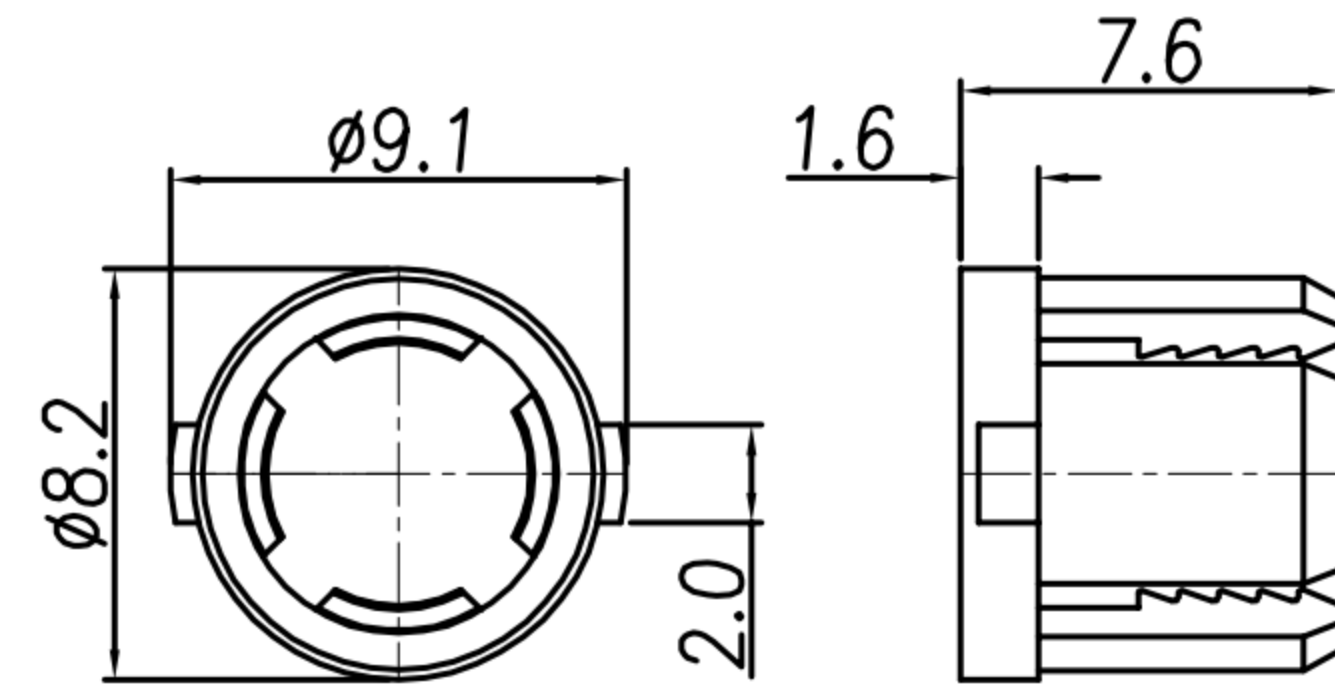

STRAIN RELIEF COLLAR

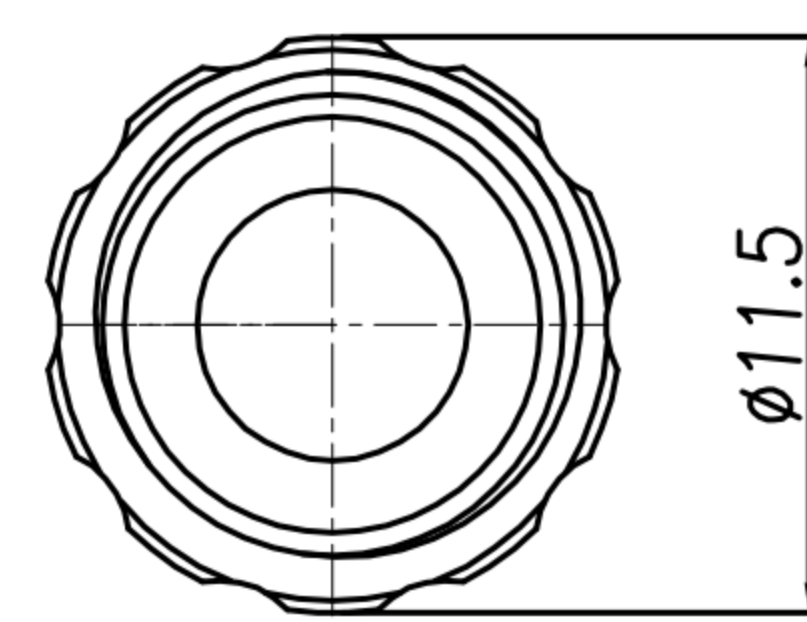

TIGHTENING COLLAR

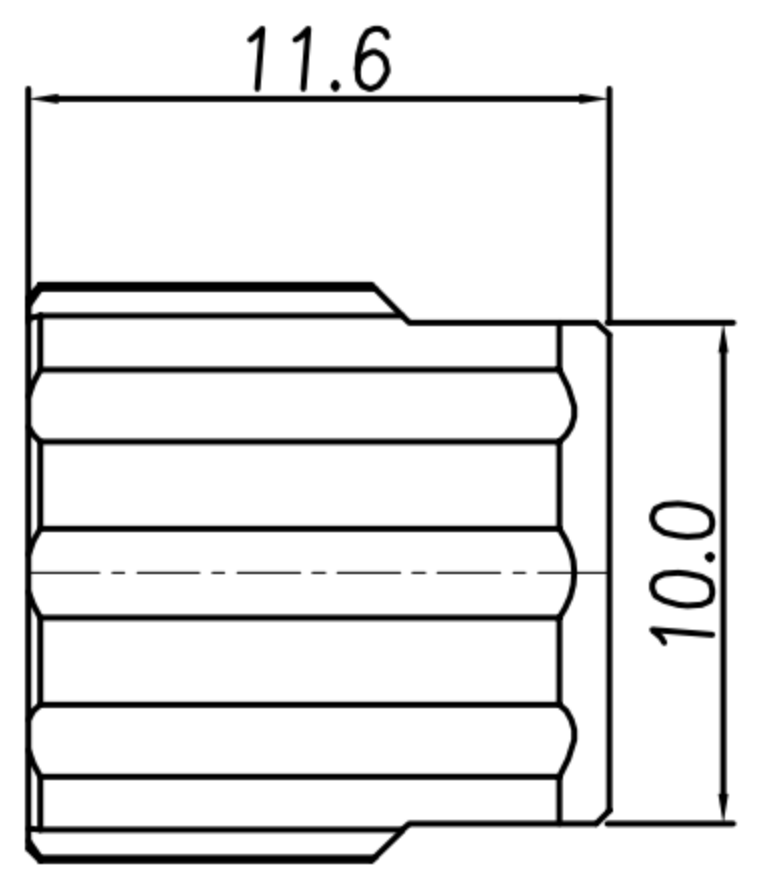

DRAWN	Mark Kao	APPVL	Ku Chou	UNIT	mm	TOLERANCE		广东科斯达电子科技有限公司 GUANG DONG KE SI DA ELECTRONIC TECHNOLOGY CO., LTD.	TITLE	WP (M) 连接器 (JACK-LF07 TYPE)			SHEET	2/2
CHK'D	Emily Suen			SCALE	1:1	.x ±0.20 .xx ±0.10 .xxx ±0.05 .xxxx ±0.03 ANGULA ±1°			PART NO.	SEE TABLE A	DWG NO.	QC5715	VERSION	A

CUSTOMER DRAWING

REV.	DESCRIPTION	APPROVED BY	DATE	ECN NO.
△A	RELEASE	Emily Suen	25/10/11'	
△B				
△C				
△D				

1. MATERIAL :

- 1-1. HOUSING : PPS UL94V-0  
COLOR : BLACK
- 1-2. CONTACT : PHOSPHOR BRONZEC
- 1-3. JACK SHELL : ZINC ALLOY
- 1-4. BACK SHELL : ZINC ALLOY
- 1-5. SHIELDING : PHOSPHOR BRONZE
- 1-6. O-RING 2 : EPDM
- 1-7. CLAMP : BRASS
- 1-8. O-RING 3 : NBR ; COLOR : BLACK
- 1-9. STRAIN RELIEF COLLAR : NYLON66 UL94V-0 ; COLOR : WHITE
- 1-10. TIGHTENING COLLAR : PPS ; COLOR : BROWN

TABLE A

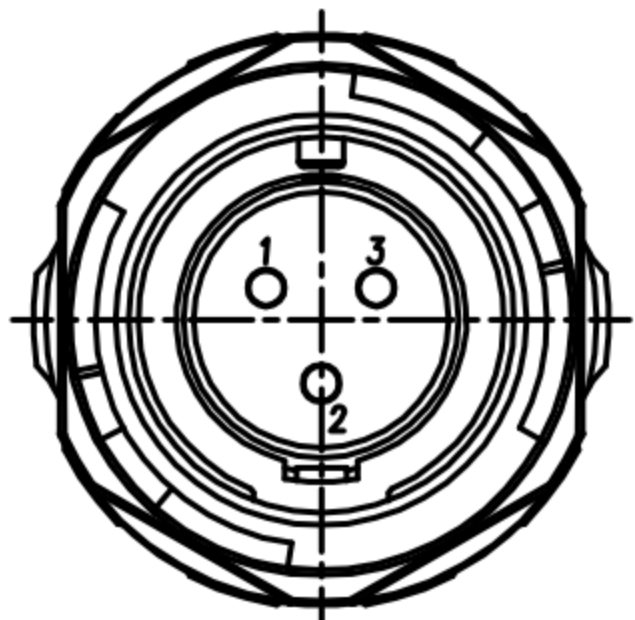
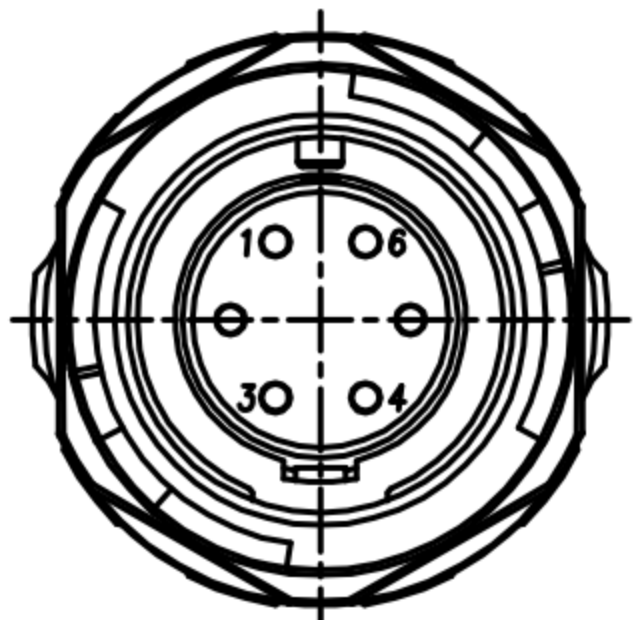
CONTACT ARRANGEMENT(FRONT VIEW)	
	
WP-03M2-29	WP-06M2-20

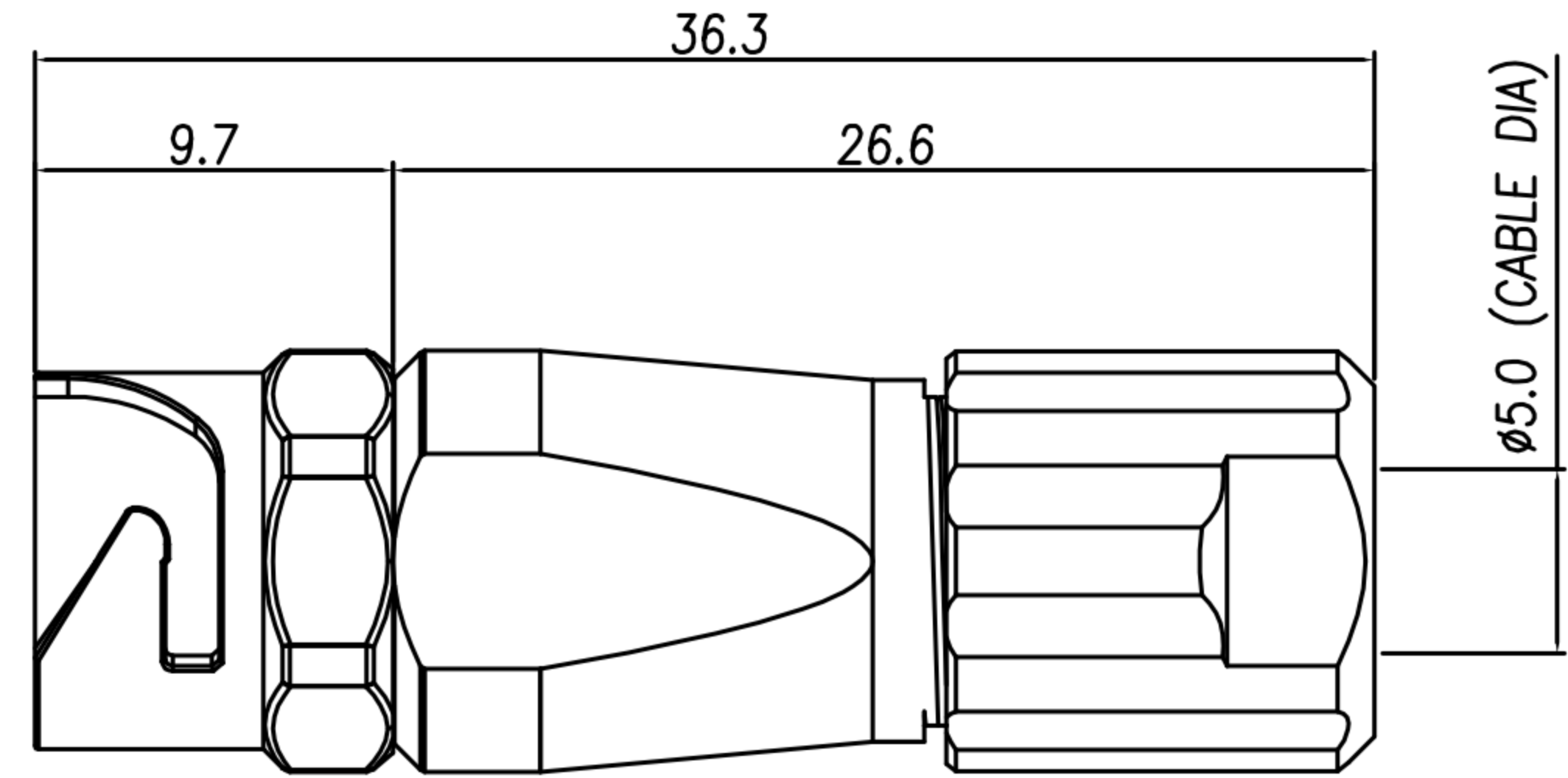

2. FINISH :

- 2-1. CONTACT : GOLD FLASH
- 2-2. JACK SHELL : NICKEL
- 2-3. BACK SHELL : NICKEL
- 2-4. SHIELDING : NICKEL
- 2-5. CLAMP : NICKEL

3. ELECTRICAL SPECIFICATION :

- 3-1. Rated current : 3PIN 5A ; 6PIN 2A
- 3-2. Rated voltage : 3PIN 125V AC / 175V DC ;  
6PIN 30V AC / 42V DC
- 3-3. Water proof : IP67

4. Environmental :

- 4-1. Operation Temperature : -25℃~85℃

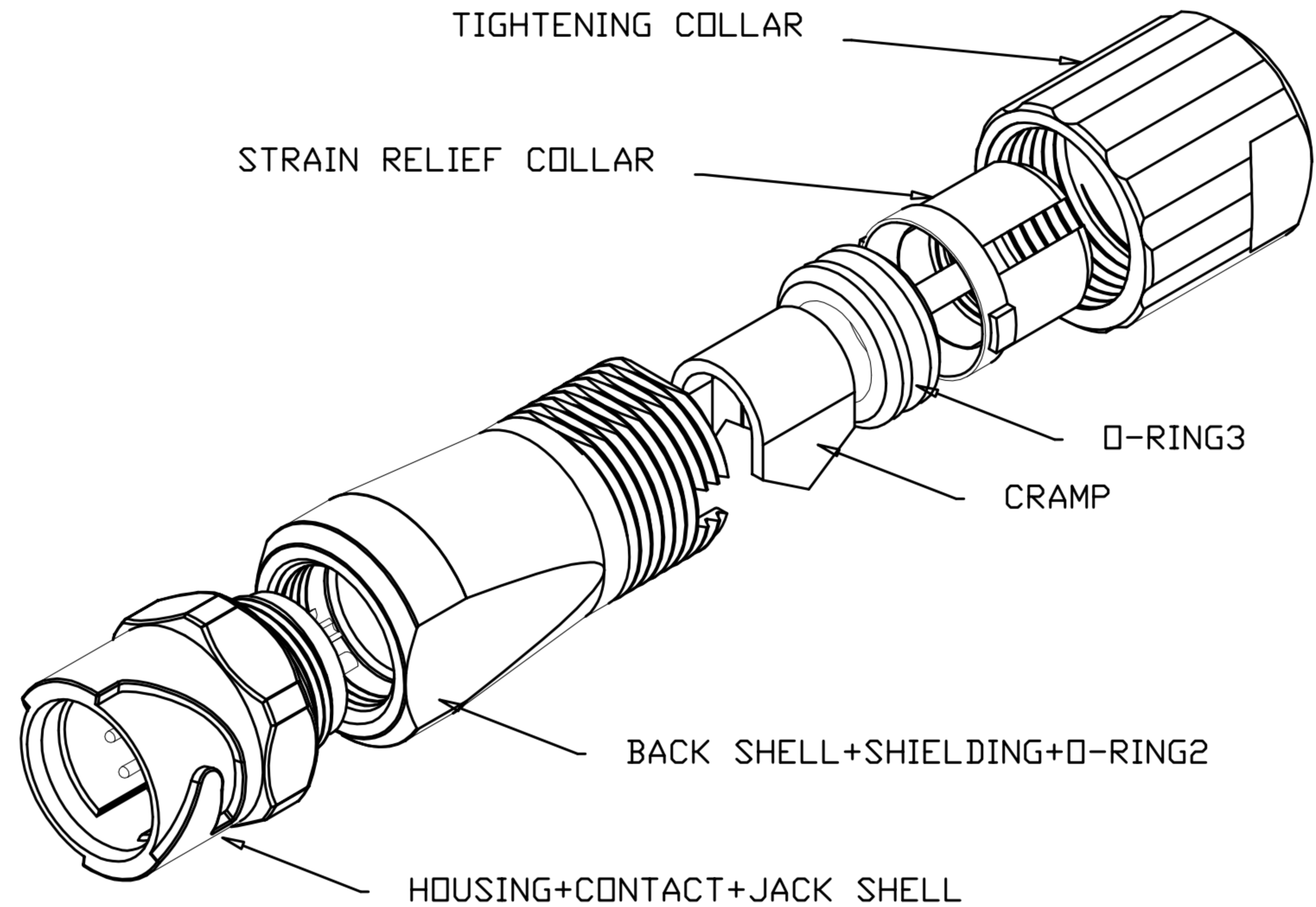

DRAWN	Mark Kao	APPV'L	Ku Chou	UNIT	mm	TOLERANCE			广东科斯达电子科技有限公司 GUANG DONG KE SI DA ELECTRONIC TECHNOLOGY CO., LTD.	TITLE	WP (M) 连接器 (JACK-LF07 TYPE)			SHEET	
CHK'D	Emily Suen			SCALE	1:1	PART NO.				SEE TABLE A	DWG NO.	QC5715	VERSION	A	